

QR 2013 – 27th International Workshop on Qualitative Reasoning Workshop Report

Mehul Bhatt, Peter Struss, Christian Freksa (co-chairs)



SFB/TR 8 Report No. 035-11/2013

Report Series of the Transregional Collaborative Research Center SFB/TR 8 Spatial Cognition
Universität Bremen / Universität Freiburg

Contact Address:

Dr. Thomas Barkowsky
SFB/TR 8
Universität Bremen
P.O.Box 330 440
28334 Bremen, Germany

Tel +49-421-218-64233
Fax +49-421-218-64239
barkowsky@sfbtr8.uni-bremen.de
www.sfbtr8.uni-bremen.de

QR 2013

Workshop report

**27th International Workshop on
Qualitative Reasoning**

Co-Chairs

Mehul Bhatt, Peter Struss, Christian Freksa

August 27–30 2013

Schloss Etelsen (near Bremen), Germany

QR 2013 ORGANIZING COMMITTEE

Program Chairs

Dr. Mehul Bhatt, Cognitive Systems (AG Freksa), University of Bremen, P.O. Box 330 440, 28334 Bremen, Germany.
T +49 (421) 218 64 237 F +49 (421) 218 98 64 237
bhatt@informatik.uni-bremen.de

Prof. Dr. Peter Struss, Technische Universität München, Institut für Informatik - Lehrstuhl IV, Boltzmannstr. 3, D-85748, Garching bei München, Germany.
T +49 (421) 218 64 237, F +49 (421) 218 98 64 237
struss@in.tum.de

Prof. Christian Freksa, PhD., Cognitive Systems, University of Bremen, P.O. Box 330 440, Bremen 28334, Germany.
T +49 (421) 218 64 237, F +49 (421) 218 98 64 237
freksa@informatik.uni-bremen.de

Supporting Committee

Dr. Carl Schultz, Cognitive Systems (AG Freksa), University of Bremen, P.O. Box 330 440, 28334 Bremen, Germany.
T +49 (421) 218-64382, F +49 (421) 218-98-64382
cschultz@informatik.uni-bremen.de

Dipl.-Inf. Jakob Suchan, Cognitive Systems (AG Freksa), University of Bremen, P.O. Box 330 440, 28334 Bremen, Germany.
jsuchan@informatik.uni-bremen.de

Administrative Assistantance

Ms. Gracia Kranz,
Ms. Susanne Schwarze
University of Bremen, Germany

Program Committee

Brandon Bennett (University of Leeds, UK)
Mehul Bhatt (University of Bremen, DE)
Kenneth D. Forbus (Northwestern University, US)
Johan de Kleer (PARC, US)
Ute Schmid (University of Bamberg, DE)
Peter Struss (Technische Universität München, DE)

Review Committee

Gautam Biswas (Vanderbilt University, US)
Stefano Borgo Laboratory (ISTC-CNR, IT)
Ivan Bratko (University of Ljubljana, SL)
George M. Coghill (University of Aberdeen, UK)
Ernest Davis (New York University, US)
Oskar Dressler (OCCM Software GmbH, DE)
Frank Dylla (University of Bremen, DE)
Antony Galton (University of Exeter, UK)
Hans Guesgen (Massey University, NZ)
Shyamanta Hazarika (Tezpur University, IN)
Tomoya Horiguchi (Kobe University, JP)
Liliana Ironi (IMATI CNR, IT)
Matthew Klenk (PARC, US)
Xenofon D. Koutsoukos (Vanderbilt University, US)
Kai-Uwe Kuehnberger (University of Osnabruck, DE)
Peter Lucas (Radboud University Nijmegen, NL)
Chris Price (Aberystwyth University, UK)
Paulo Salles (University of Brasilia, BR)
Tim Shipley (Temple University, USA)
Kazuko Takahashi (Kwansei Gakuin University, JP)
Stefania Tentoni (IMATI CNR, IT)
Tetsuo Tomiyama (Cranfield University, UK)
Stefan Woelfl (University of Freiburg, DE)
Diedrich Wolter (University of Bremen, DE)
Jure Zabkar (University of Ljubljana, SL)

Acknowledgements

QR 2013 has been generously funded by the German Research Foundation (DFG). The Cognitive Science Society supported a best student paper award in the area of cognitive science.

Contents

Preface	v
<i>Mehul Bhatt, Peter Struss, and Christian Freksa</i>	
Invited Talks	vi
<i>Nancy Nersessian</i>	
<i>Gautam Biswas</i>	
Tutorial	viii
<i>Stefano Borgo</i>	
Panel Discussion	ix
<i>Robotics' challenges for Qualitative Reasoning about the Physical World – or maybe not?</i>	
Full Papers	
1 Using Modelica Models for Qualitative Reasoning	1
<i>Matthew Klenk, Johan de Kleer, Daniel Bobrow and Bill Janssen</i>	
2 QUANTUM: Qualitative Abstractions of Non-polynomial Models	9
<i>William Denman</i>	
3 A Logic Approach for Qualitative Sum and Product	17
<i>Alfredo Burrieza, Emilio Muñoz-Velasco and Manuel Ojeda-Aciego</i>	
4 Using Planning with Qualitative Simulation for Multi-Strategy Learning of Robotic Behaviours	24
<i>Timothy Wiley, Claude Sammut and Ivan Bratko</i>	
5 Perceptual Narratives of Space and Motion for Activity Interpretation	32
<i>Jakob Suchan, Mehul Bhatt and Paulo E. Santos</i>	
6 Using Narrative Function to Extract Qualitative Information from Natural Language Texts: A Preliminary Report	40
<i>Clifton Mcfate, Kenneth Forbus and Thomas Hinrichs</i>	
7 Towards Cognitive Image Interpretation by Mixing Qualitative Image Descriptions and Feature Object Detectors	47
<i>Zoe Falomir, Lledó Museros, Luis Gonzalez-Abril, Diedrich Wolter, and Christian Freksa</i>	
8 Traffic Sign Recognition with Qualitative Theories	55
<i>Lledó Museros, Zoe Falomir, Ismael Sanz and Luis Gonzalez-Abril</i>	

9	Automated Safety Analysis of Vehicles Based on Qualitative Behavior Models and Spatial Representations <i>Peter Struss and Sonila Dobi</i>	63
10	Group Decision-Making System based on a Qualitative Location Function: An Application to Chocolates Design <i>Núria Agell, Germán Sánchez, Mónica Sánchez and Francisco Ruiz</i>	71
11	An Immune Network Approach to Qualitative System Identification of Biological Pathways <i>Wei Pang and George Coghill</i>	77
12	A Qualitative Framework for Deriving a Terrain Feature <i>Shinya Enomoto and Kazuko Takahashi</i>	85
13	Qualitative Knowledge and Memories within a Creative Decision-Making Process: A Case-Study in Architecture Planning and Design <i>Dino Borri, Domenico Camarda and Rossella Stufano</i>	93
14	Adding Perspectival Location to a Mereo-Topological Theory of Spatial Representation <i>Marion Haemmerli</i>	100
15	Towards a Mereotopology with Pointfree Semantics <i>Stefano Borgo</i>	108
16	A First-Order Axiomatization of Change in Mereotopology <i>Bahar Aameri and Michael Gruninger</i>	115
17	Qualitative Spatial Representation and Reasoning in Angry Birds: First Results <i>Peng Zhang and Jochen Renz</i>	123
18	Understanding Human Spatial Conceptualizations to Improve Applications of Qualitative Spatial Calculi <i>Jan Oliver Wallgrün, Alexander Klippel, Jinlong Yang and Frank Dylla</i>	131
19	Using Observations to Derive Cardinal Direction Relations between Regions <i>Tao Wang, Hui Shi and Bernd Krieg-Brückner</i>	139

Preface

Qualitative Reasoning (QR) is a research area at the interface of Artificial Intelligence, Cognitive Science, Engineering, and Science. Its core objective is to model and reason about real world systems at a conceptual and abstract level. In seeking to understand the human ability to reason qualitatively, QR combines the quest for comprehension of effective reasoning about systems, even with incomplete or qualitative knowledge and information, and new ways to supplement conventional modeling, analysis, diagnosis, and control techniques to tackle real-world applications.

QR workshops are annually organised at different locations internationally: QR 2013 in Bremen is the 27th occurrence of this event in a long series that has helped define the field of Qualitative Reasoning. Recent QR workshops have been organized in California, USA (2012); Barcelona, Spain (2011); Portland, USA (2010); Ljubljana, Slovenia (2009), University of Colorado, USA (2008). The scientific agenda of QR 2013 addresses fundamental research questions in qualitative modelling, reasoning, and computing, as well as their applications in a wide-range of domains such as Ambient Intelligence and Smart Environments, Environmental Modelling and Simulation, Geographic Information Systems, Computational Creativity, Experimental Cognitive Robotics, Computer-Aided Learning and Education, Computer-Aided Design and Analysis for Engineering, Architecture, Urban Planning, Product Design. QR 2013 brings together researchers in qualitative reasoning, commonsense reasoning, cognitive systems and interaction technologies, and practitioners of theoretical and applied artificial intelligence for engineering and decision-support systems. QR 2013 categorically welcomed application and theoretical contributions that emphasise the development of systematic human-centred models and methods for commonsense qualitative reasoning that may be seamlessly integrated within larger artificial intelligence projects, cognitive (assistance) systems, industrial automation systems, and hybrid intelligent systems.

Contributions at QR 2013 and other most recent QR workshops reflect a broad interdisciplinarity comprising of Artificial Intelligence, Cognitive Science, and Engineering. From the viewpoint of basic research questions, QR 2013 aimed to strengthen this interdisciplinary interface by directly appealing to other fields such as: Commonsense and Non-Monotonic Reasoning, Geometric, Spatial and Temporal Reasoning, Visual and Diagrammatic Reasoning, Analogical Reasoning, Formal and Applied Ontology. Invited keynote speakers and tutorial presenters have been chosen to promote the core topics of qualitative (spatial) reasoning and interaction in the above stated areas and communities that are closely connected to qualitative reasoning, but are pursued by researchers as a part of other research fields. For instance, a particular success of QR 2013 has been the coming together of researchers in qualitative reasoning, and qualitative spatial representation and reasoning. It is our hope that such interdisciplinary interactions will persist, that the QR 2013 workshop report will provide impulses for new researchers to address the theory and practice of qualitative reasoning, and also to join the QR community in future events.

Mehul Bhatt, Peter Struss, Christian Freksa
(QR 2013 Co-Chairs)

Invited Keynote Talk

Engineering Analogies: Model-Based Reasoning in Bioengineering Sciences

Research on analogy in the cognitive sciences has largely been based on cases in which the analogical source is ready-to-hand. In my research on creative analogies in historical scientific discoveries, I argued that in many instances the source analogy itself needs to be constructed in an iterative process of building conceptual models that incorporate both target and source domain constraints. Now I have been extending that research to examine the processes of building physical and computational models. In the bioengineering sciences whole fields are based on the practice of “engineering” in vitro and in silico models to serve as source analogies through which to reason about biological phenomena that for reasons of experimental control, complexity, or ethics cannot be experimented on in vivo. I will examine some cases based on my 12-year ethnographic study of these practices in bioengineering research labs and discuss the implications for both a richer understanding of analogy and of how scientists build cognitive powers through building modeling environments.

Nancy Nersessian

Georgia Institute of Technology

UNITED STATES OF AMERICA

Invited Keynote Talk

Case Studies in Qualitative Modeling and Reasoning

The field of Qualitative Reasoning (QR) has come a long way since the first workshop was held in 1986. Among other applications QR methods have been extensively used in K-12 STEM education, cognitive modeling, as well as engineering applications in diagnosis, design, and verification. In this talk, I will focus on case studies of the applications of QR that are directly and indirectly related to my research in (1) developing computer-based learning environments to help K-12 students gain a deep understanding of science phenomena, and (2) developing efficient methods for diagnosis of dynamic systems. In addition, I will also discuss the role of QR and related methods for verification of vehicle designs in the Adaptive Vehicle Make (AVM) project that I participate in. I will use the case studies to illustrate the important and essential role QR techniques play in these applications, but also bring up some limitations that may be addressed by aligning QR methods with more quantitative analyses.

Gautam Biswas

Vanderbilt University

UNITED STATES OF AMERICA

Tutorial

Mereology, Geometry, and Shapes

The tutorial gives an introduction to the perspective of qualitative space representation based on mereology and highlights how geometrical thinking depends on the primitives one adopts. We begin by introducing the motivations for formal theories based on the notion of parthood and connection (mereotopologies) and then present some extensions developed to talk about spatial features (mereogeometries). Beside a formal introduction of these systems, we show how to compare them and how they can be used. We pay particular attention to systems built out of standard geometrical figures like squares, spheres and regular triangles; and play with these to find ways to build other classical figures. Finally, we explore different ways to "understand" Euclidean points in these systems. Throughout the course, ontological considerations and practical manipulation of figures will lead to discuss how to think about geometry.

The course is self-contained and assumes only basic knowledge of Euclidean geometry. Some knowledge of first-order logic would be helpful. Core topics covered are:

- qualitative geometry and mereological geometry: what and why
- introduction to mereology and mereogeometry as formal systems
- playing and thinking with geometrical figures
- constructing points in mereogeometry

Stefano Borgo
ISTC-CNR
ITALY

Panel Discussion

Robotics' challenges for Qualitative Reasoning about the Physical World – or may be not?

Panel members (tentative):

- Michael Beetz (University of Bremen, Germany)
- Ivan Bratko (University of Ljubljana, Slovenia)
- Paul Ploeger (Bonn-Rhine-Sieg University of Applied Sciences, Germany)
- Franz Wotawa (Graz University of Technology, Austria)

Using Modelica Models for Qualitative Reasoning

Matthew Klenk and Johan de Kleer and Daniel G. Bobrow and Bill Janssen

Palo Alto Research Center
3333 Coyote Hill Rd
Palo Alto, CA, 94303
klenk,dekler,bobrow,janssen@parc.com

Abstract

Applications of qualitative reasoning to engineering design face a knowledge acquisition challenge. Designers are not fluent in qualitative modeling languages and techniques. To overcome this barrier, we perform qualitative simulation using models solely written in Modelica, a popular language for modeling hybrid systems. We define the relationship between the results of the Modelica and qualitative simulations and describe how qualitative simulation from numerical models can assist designers. We discuss challenges and solutions for abstracting equations into constraints, determining initial conditions, continuous behavior, and discrete events. In particular, we identify three places where additional constraints should be derived from Modelica equations, and describe how we bridge the gaps between Modelica and existing qualitative simulation work on discrete behavior. Our system has been integrated with the Open-Modelica¹ tool and we discuss its potential design applications.

1 Introduction

Over the last half century, industry and academic professionals have developed a plethora of modeling languages and tools to analyze designs. Centered around a particular set of analyses, each tool requires the designer to specify the problem in a particular way and interpret the analysis results with respect to their design question. The languages and analyses of qualitative reasoning have not made inroads into the engineer's practice. Consequently, with a few notable exceptions (e.g., [Struss and Price, 2004]), qualitative reasoning has not been applied in industrial design settings.

We seek to overcome this barrier for the DARPA Adaptive Vehicle Make program², which seeks dramatically reduce the cost and time required to design, verify and manufacture complex cyber-physical systems. Our role is to integrate qualitative reasoning into the CyPhy toolchain [Simko *et al.*, 2012] for use by designers and system engineers. The

CyPhy toolchain uses Modelica [Fritzson, 2004] to model hybrid systems. Therefore, to enable designers to use qualitative reasoning techniques, it is necessary to automatically translate Modelica models into qualitative models. In this paper, we discuss challenges and solutions to automatically translating Modelica into models for qualitative reasoning [Kuipers, 1994][de Kleer and Brown, 1984].

We believe [Weld and de Kleer, 1989] qualitative reasoning helps engineers set up quantitative analyses and interpret the results. Therefore, automating these tasks should free the designer to consider more challenging design problems. Using only qualitative simulation, the following questions can be answered automatically: (1) If a simulation fails to meet the requirements, should the engineer change the parameters or the topology? (2) Does the simulation include numerical instabilities or missed events? In previous work on battlespace planning [Hinrichs *et al.*, 2011], we showed how qualitative simulation could guide probabilistic analysis enabling the guided approach to analyze models in a fraction of the time as traditional methods. In addition to automatically interpreting simulation results and guiding quantitative analyses, qualitative models provide an alternative framework to probability distributions for capturing the inherent uncertainty of modeling that can be reasoned over symbolically. These benefits can be realized by performing qualitative reasoning from quantitative models.

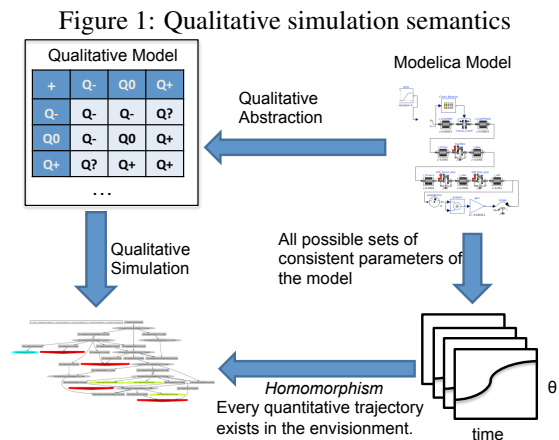

¹www.openmodelica.org

²http://en.wikipedia.org/wiki/Adaptive_Vehicle_Make

Figure 2: The Modelica analysis process begins with the user creating hierarchical numerical Modelica model, frequently with the use of a GUI (such as OMEdit). Next the analysis is performed by compiling the model into a hybrid differential and algebraic representation which is then solved. The result is a table of numeric values for every model variable over time, which is typically presented to the user in the form of a graph.

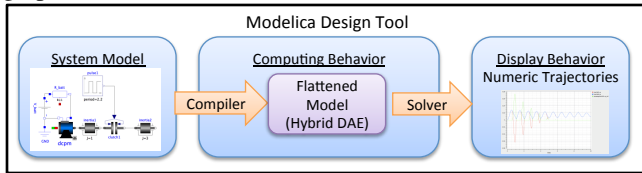

When performing model translation, it is necessary to define the relationship between the simulation results. We define that a qualitative abstraction maintains the following relationship between Modelica and qualitative simulations (shown in Figure 1). Given a Modelica model (upper right), we create qualitative model of constraints (upper left) from which we perform a qualitative simulation to produce an *envisionment* (lower left). The meaning of this envisionment is that every consistent assignment of parameters in the Modelica model will result in a quantitative simulation (lower right), and each correct quantitative simulation will correspond to a trajectory in the envisionment. The translation is incorrect if there exists a set of valid quantitative parameters that generate a quantitative simulation that does not correspond to any trajectory in the envisionment. The techniques described in this paper are correct under this definition.

Directly translating the Modelica equations into qualitative constraints results in an envisionment with numerous unrealizable trajectories (i.e., there is no corresponding set of numeric parameter which generates a corresponding quantitative simulation). While unrealizable states and trajectories are an unavoidable problem for qualitative simulation [Struss, 1988], by making the implicit information of equations explicit, we reduce the set of unrealizable trajectories improving the utility of the resulting envisionment. When creating the qualitative model, we expand the set of constraints from those that appear explicitly in the hybrid differential and algebraic equations (hybrid-DAE) with the following three types of quantitatively redundant relations: (1) the continuity and compatibility equations from system dynamics, (2) equalities between higher-order derivatives, and (3) landmark ordering. In addition to continuous behavior, Modelica allows for discrete behaviors. Traditional approaches to qualitative modeling of discrete behavior require additional modeling knowledge not directly accessible in the hybrid-DAE. We describe an approach to overcome this lack of knowledge and show that it respects the semantics in Figure 1. Furthermore, we introduce *pseudo state variables*, qualitative variables that maintain their values through discrete transitions, to reduce unrealizable trajectories.

2 Dynamics Modeling in Modelica

Figure 2 illustrates the modeling and simulation process used to analyze Modelica models. The process begins with the user creating a hierarchical Modelica model, frequently with the use of a graphical user interface. Next, the simulation is performed by compiling the model into a flattened Modelica model that is represented as a set of hybrid differential and algebraic equations (DAE). Given a DAE, an equation solver (e.g., DASSL [Petzold, 1982]) produces a sequence of numeric values for every model variable, which is typically presented to the user in the form of a graph.

We previously identified the Hybrid-DAE as the correct point to abstract the Modelica model into a qualitative model [Klenk *et al.*, 2012]. Abstracting this representation has the advantages of allowing designers to use the Modelica model construction language and models from the Modelica Standard Library in creating their designs.

2.1 Hybrid Differential Algebraic Equations

In Modelica, the continuous-time behavior is governed by differential (1) and algebraic (2) equations with state variables, x , algebraic variables, y , and inputs, u .

$$\dot{x}(t) = f(x(t), y(t), u(t)) \quad (1)$$

$$y(t) = g(x(t), u(t)) \quad (2)$$

Discrete changes occur at events specified by conditions that change in truth value. Conditions on continuous variables are analogous to landmarks in qualitative modeling. Events result in new values for discrete-time variables and a new set of equations to govern the continuous dynamics. In the following section, we describe how these Modelica equations are abstracted into constraints and used for qualitative simulation.

3 Qualitative Simulation with Modelica Models

Our constraint-based qualitative simulator draws on the ideas from established methods [de Kleer and Brown, 1984] [Kuipers, 1994]. To perform qualitative simulation with Modelica models, it is necessary to perform the following tasks: create the qualitative model, initialize the qualitative state, and simulate the continuous and discrete behavior. In the following sections, we describe each in turn.

3.1 Abstracting the Hybrid-DAE

While the qualitative research community has established methods for generating constraints from differential equations [Kuipers, 1994], the hybrid-DAE produced by the Modelica flattening process requires additional techniques. The established method for abstracting equations is as follows. If the equation consists of three or fewer variables, we create the corresponding qualitative constraint directly. For equations with more than three variables, such as the ramp torque source equation in Figure 3, we replace pairs of variables with *dummy* variables representing their combination and generate the corresponding constraint. We do this recursively until the original equation consists of only three variables. The ramp

torque source equation also includes conditions. Therefore, we use conditional constraints to govern the appropriate equations. For example, *dummy3* is mentioned in two conditional constraints to either be equal to *ramp1.height* or *dummy6* depending on the value of the condition, *dummy4*.

Figure 3: Conditional expressions in Modelica equations are transformed into conditional constraints that set the values of dummy variables.

Modelica equation:

```
torque1.tau = ramp1.offset +
  if time < ramp1.startTime
  then 0.0
  else if time < ramp1.startTime + ramp1.duration
  then (time - ramp1.startTime) ×  $\frac{\text{ramp1.height}}{\text{ramp1.duration}}$ 
  else ramp1.height;
```

Qualitative constraints:

```
torque1.tau = ramp1.offset + dummy1
dummy1 = { 0.0      if dummy2 < 0
          dummy3   if dummy2 ≠ 0
dummy2 = time - ramp1.startTime
dummy3 = { dummy6   if dummy4 < 0
          ramp1.height if dummy4 ≠ 0
dummy4 = time - dummy5
dummy5 = ramp1.startTime + ramp1.duration
dummy6 = dummy7 × dummy8
dummy7 = time - ramp1.startTime
dummy8 =  $\frac{\text{ramp1.height}}{\text{ramp1.duration}}$ 
```

In the next three sections, we describe additional constraints that we add by analyzing the hybrid-DAE.

Continuity and Compatibility Conditions

System dynamics theorems specify the minimal set equations necessary to enforce the continuity and compatibility conditions (e.g., Kirchoff’s Voltage and Current Laws), and this minimal set of equations is contained in the hybrid-DAE. These theorems do not hold for qualitative arithmetic [de Kleer and Brown, 1984]. Therefore, it is necessary to compute the quantitatively redundant node and loop constraints by combining continuity and the compatibility equations. Consider the two Modelica equations shown in Figure 4. By adding these equations together, we derive the qualitative constraint that $g1.p.i = 0.0$, thereby reducing the number of unrealizable transitions in the resulting simulation.

Higher-order Derivative Equalities

Another technique for generating additional constraints concerns equalities between variables with explicit derivatives.

Figure 4: Due to ambiguities in qualitative algebra, quantitative equations for system dynamics must be symbolically combined to create additional qualitative constraints.

Modelica equations:

$$\begin{aligned} r2.i + c1.i + cv1.i &= 0.0; \\ g1.p.i - c1.i - r2.i - cv1.i &= 0.0; \end{aligned}$$

Additional qualitative constraint:

$$g1.p.i = 0.0$$

Consider the equations in Figure 5 modeling a brake attached to a flywheel. While their positions and speeds are equal, the hybrid-DAE represents this in three equations. Converting only those equations to qualitative constraints fails to capture the equality between the speeds. Therefore, for any two variables with explicit derivatives that are equal, we add equality constraints between their derivatives.

Figure 5: If two variables are equal, then their explicit derivatives must also be equal.

Modelica equations:

$$\begin{aligned} \text{brake1.phi} &= \text{flywheel1.phi}; \\ \text{brake1.w} &= \text{der}(\text{brake1.phi}); \\ \text{flywheel1.w} &= \text{der}(\text{flywheel1.phi}); \end{aligned}$$

Additional qualitative constraint:

$$\text{brake1.w} = \text{flywheel1.w}$$

Partially Ordered Landmarks

The Modelica hybrid-DAE does not explicitly create quantity spaces. Instead, landmark variables are the result of event conditions. Consider the equation in Figure 6. The equation states that the *startForward* variable is *true* when the brake was stuck and the variable *sa*, a path parameter for the torque applied to the brake, is greater than the maximum torque of the brake, or the brake had begun moving and *sa* is greater than the sliding friction of the brake. Implicit in this equation are two landmarks for the variable *sa* (*tau0_max* and *tau0*). *landmark1* and *landmark2* are created by the process described in Section 3.1. The third constraint provides an ordering for the two landmarks and can be generated either by the parameter values in the hybrid-DAE or passed as arguments to the qualitative simulation system.

3.2 Initialization

During initialization and every discrete event, Modelica determines the values of the model variables, the derivative for each continuous variable, and the *pre* value (i.e., the value in the left limit before the initial instant) for each discrete variable. Initialization is provided with a set of initial values, which, for continuous variables, are assigned to the initial state, and, for discrete variables, are assigned *pre* values.

Figure 6: A Modelica conditional equation specifying two landmarks for the *brake1.sa* quantity space and the corresponding additional qualitative constraints defining these landmarks and their order.

Modelica equation:

```
brake1.startForward =
  pre(brake1.mode) == Stuck
  and (brake1.sa > brake1.tau0_max or
       pre(brake1.startForward)
       and brake1.sa > brake1.tau0)
  or initial() and brake1.w > 0.0;
```

Qualitative landmark variables and constraints:

$$\begin{aligned} \text{landmark1} &= \text{brake1.sa} - \text{brake1.tau0_max} \\ \text{landmark2} &= \text{brake1.sa} - \text{brake1.tau0} \\ Q_+ &= \text{landmark1} - \text{landmark2} \end{aligned}$$

Given these values, Modelica tools solve the equation system to determine a consistent set of values for the other variables. When the user-provided initial values do not uniquely determine the values for the other variables in the system, Modelica tools search for a consistent initial state using defaults (e.g., 0 for continuous variables) and user-provided suggested values. The initial quantitative state is dependent on the numeric values given to parameters. Qualitative simulation explores the partially ordered parameter space. Therefore, it is necessary to determine the set of initial qualitative states using the qualitative constraints.

To satisfy the semantics in Figure 1, our qualitative simulation tool must generate the corresponding qualitative initial state. If there are variables that are not determined by the constraints and initial values, we replace the initial instant with a set of initial instants by performing constraint satisfaction to identify all possible qualitative values for the unknown variables that are consistent with the constraints. Our approach generates an initial state for every consistent set of qualitative values. Because the quantitative solution generated by Modelica is consistent with the equation set, and the qualitative constraints are an abstraction of this equation set, then the corresponding qualitative values for these variables must satisfy the qualitative constraints. Therefore, our generated set of initial instants necessarily includes the single initial state selected by the Modelica, thereby aligning our approach with Modelica.

3.3 Continuous Integration

In constructing the hybrid-DAE, Modelica compilers perform index reduction to arrive at an index-1 DAE. Thus, every continuous-time variable is differentiable with respect to time, and therefore, equivalent to the *reasonable functions* [Kuipers, 1994]. Therefore, by the *guaranteed coverage theorem* [Kuipers, 1994], given a sound abstraction of equations into constraints, the correct continuous behavior of the Modelica model must appear in the envisionment.

The alignment of Modelica simulation and qualitative behaviors has three features of note. First, qualitative state changes in the envisionment occur when any variable or its derivative crosses zero. While Modelica varies its integration step size when searching for *events* (i.e., changes in the conditions of equations), zero crossings that do not effect the dynamics of the system are ignored. Therefore, if the integration step size is too large, it may not be possible to know if a variable crossed zero at the same instant as another. Second, qualitative simulation produces unrealizable transitions and states. It is an active area of qualitative simulation research to determine under what circumstances qualitative constraints simulation do not result in such behaviors [Sachenbacher and Struss, 2005][Yilmaz and Say, 2006]. Third, Modelica simulators are susceptible to numerical integration errors. These incorrect simulations have no defined relationship with the envisionment. Consequently, when the qualitative abstraction of a Modelica simulation does not occur in the envisionment, we can signal a numeric integration error.

3.4 Discrete Changes

The challenge in aligning Modelica’s discrete behavior [Oster *et al.*, 1999] with qualitative simulation lies in the lack of agreement among different qualitative simulation methods. After a short description of Modelica’s discrete-time semantics, we discuss the different approaches from qualitative reasoning and illustrate our approach with a concrete example aligning the simulation results.

Discrete-time Behavior in Modelica

In Modelica, discrete changes occur at *events*. These are changes in the conditions of equations resulting in new equations governing the behavior of continuous-time variables and/or new values for discrete-time variables. An event occurs when a condition changes from *false* to *true*. Events in Modelica are governed by the *synchronous data-flow principle* which states the following. First, events take no time. Second, the number of equations equal the number of variables. Third, all variables maintain their actual values until these values have been explicitly changed. Fourth, at every point in time, the solution to the set of *active* equations must be satisfied concurrently. Events may change the values of discrete variables or the set of active equations. Events may cause other events. While sequential, the entire event sequence has no duration.

Previous Approaches from Qualitative Simulation

While numerous approaches to qualitative simulation have addressed issues surrounding discrete events, they all require additional modeling than what is contained in Modelica’s hybrid-DAE. For example, QSIM [Kuipers, 1994] requires a transition mapping function when there is a change in operating regions. This function includes the new set of constraints, the variables whose magnitudes are unchanged, the variables whose derivatives are unchanged, and any values that must be asserted. This information is not directly accessible from the hybrid-DAE. De Kleer and Brown’s qualitative physics based on confluences [de Kleer and Brown, 1984] uses *modes* and propagates non-local discrete changes through heuristics to provide a causal account of device behavior. Nishida and

Doshita [Nishida and Doshita, 1987] present two methods for handling discrete changes in qualitative simulation: (1) model it as continuous change that happens over infinitesimals, (2) model it as a sequence of mythical instants which may be inconsistent with the model. Iwasaki *et al.* [Iwasaki *et al.*, 1995] formulate instantaneous discrete changes using rules and hyperreal time semantics. Our approach pulls pieces from these approaches to allow discrete transitions using the hybrid-DAE.

Accounting for Modelica Events in Qualitative Simulation

Given a zero crossing, our qualitative simulation approach determines if there has been any change in the conditional constraints. If there has, then a discrete event occurs. The discrete event provides us with a new set of conditional constraints that we use to compute the results of the event as follows: (1) identify which variables are constant through the event, (2) solve for all consistent qualitative states using the new constraints and constant variables, (3) for each new consistent state, if it has the same constraints then return it, otherwise, trigger another discrete event. In previous approaches, step 1 is either performed using heuristics [Nishida and Doshita, 1987] or required as input [Kuipers, 1994]. We use a combination of the state variables specified by Modelica and the difference between the new and old constraints to determine which variables cannot change value discontinuously. Overall, our approach is analogous to Modelica’s in that we are searching for a consistent set of values and conditions, with the state variables maintaining their values. Therefore, one of the intervals after the discrete transition must match the continuous-time behavior of the Modelica model after the event.

Alignment of Simulation Results

Consider an example of a locked brake that is subject to an increasing torque until it begins sliding. Table 1 contains a subset of the values generated by OpenModelica for the relevant variables as the brake begins sliding. At $time = 0.25$, the condition for *startForward*, $torque1.tau > 0.25$, signals a zero crossing. The search for consistent equations results in new values for the friction being applied by the brake, *brake1.tau*, its acceleration, and the boolean variables *locked* and *startForward*. From the consistent set of equations at $time = .25000001$, another zero crossing is detected for the condition $w > 0$. The result of this event is that the *startForward* is *false*, and the *mode* is *forward*. After these two events, continuous integration begins and updates the values of the continuous-time variables. Even though events have no duration, OpenModelica increments time by $1E-9$ for each set of concurrent events allowing for the sequence of instantaneous events to be recreated.

Figure 7 contains the relevant portion of the qualitative simulation produced by the Modelica model. Our algorithm is analogous to Modelica’s with the difference that we record the results of search for the consistent set of equations in the envisionment. Thus, the first zero crossing occurs when $torque1.tau > 0.25$ in situation 2931. At this point, the constraints have changed. Therefore, we create a new situation (situation 3004) with the same values for the state variables,

and then we solve for the rest of the variables. In this case, the value of *startForward* resulting in a new set of constraints being active. This process repeats until situation 3156 which has the same constraints as situation 3080. At this point, the values in this situation correspond to the row in the Modelica simulation results at $time = 0.250000001$ from Table 1. The result of the next qualitative continuous integration triggers another event when $w > 0$. This event proceeds in the same manner resulting in a situation 4022 that corresponds to the Modelica simulation at $time = 0.250000002$.

Pseudo State Variables

One weakness of our approach is that it occasionally results in the ambiguous branching (i.e., many different sequences of instants following a single discrete change). Therefore, we allow the user to specify additional qualitative variables, *pseudo-state variables*, that do not change during discrete transitions. A piece of future work is to more tightly integrate our qualitative simulator with a symbolic equation solver (e.g., Macsyma [Bogen, 1986]) to be able to identify constant variables by their equations with respect to the system’s state variables. Even with this extension, discrete transitions may introduce unrealizable ambiguities. As these transitions are extra, we maintain the desired alignment between the envisionment and the results of qualitative simulation.

4 Impact for Designers

By integrating qualitative reasoning into design tools, we foresee many potential benefits for designers. Including qualitative verification [Klenk *et al.*, 2012] where the tool would inform the engineer if the topology could meet the model’s requirements (i.e., if a failure behavior is not possible). Other benefits would include highlighting potential failures and identifying irrelevant parameters. For example, a slider-crank mechanism will exhibit a kinematic singularity in a particular context of use. Furthermore, integration with a symbolic solving system such as Macsyma has the potential to reduce the design space further by identifying key parameter inequalities that remove safety requirement violations from the envisionment.

While spurious trajectories are a concern for qualitative simulation in isolation, we intend to use qualitative simulation in conjunction with other reasoning methods. Thus, the existence of spurious states and transitions will be identified by other analyses. Limiting spurious trajectories at a qualitative level is still important because the less spurious trajectories in the envisionment the better guidance qualitative simulation provides for other reasoning methods.

5 Discussion

We believe [Weld and de Kleer, 1989] qualitative reasoning is the fundamental basis upon which engineers reason about physical systems. Qualitative reasoning plays a key role in every facet of designing a system ranging from early stage design [Kurtoglu and Campbell, 2009] through understanding of simulation results, to planning design modifications to meet requirements. Unfortunately, none of the commonly

Table 1: Values generated by OpenModelica during the discrete transition during which brake begins to move. ‘+’ indicates that the value has been truncated for presentation, and the real value is slightly greater than the value in the field. The headings ‘phi’, ‘w’, and ‘a’ correspond to the position, speed, and acceleration respectively of the brake. ‘Brake1.tau’ is the force applied by the brake against the applied torque of the system, ‘torque1.tau’.

time	phi	w	a	brake1.tau	torque1.tau	locked	startForward	mode
0.248	0	0	0	0.248	0.248	true	false	stuck
0.25	0	0	0	0.25	0.25	true	false	stuck
0.250000001	0	0	0.125+	0.125	0.25+	false	true	stuck
0.250000002	1.2E-13	1.2E-10	0.125+	0.125	0.25+	false	false	forward
0.252	2.51E-7	0.000252	0.127	0.125	0.27	false	false	forward

used design/analysis tools provide computational QR support for these tasks. Leaving qualitative reasoning entirely to the human engineer risks missing critical inferences.

Our vision is to integrate qualitative reasoning into the tools and languages used by designers enabling the automation of these tasks. This paper presents a key step in that process by performing qualitative simulation with Modelica models, extending the qualitative constraint abstraction process to account for the representations used by quantitative solvers, and highlighting the challenges of discrete modeling as well as providing a solution that maintains the desired alignment between the simulation results.

In industry and academia, the role of computation in engineering design is rapidly expanding. Clearly, only producing an envisionment will not have much of an impact on the design process. Further exploration is required to determine how best to integrate qualitative reasoning into this process. We believe that an integrated qualitative reasoning design tool will enable the designer to explore the design space more thoroughly with less computation. This will allow the designer to focus more effort on the difficult problems thereby arriving at better design faster.

Acknowledgments

This work was partially sponsored by The Defense Advanced Research Agency (DARPA) Tactical Technology Office (TTO) under the META program and is Approved for Public Release, Distribution Unlimited. The views and conclusions in this document are those of the authors and should not be interpreted as representing the official policies, either expressly or implied, of the Defense Advanced Research Projects Agency or the U.S. Government.

References

- [Bogen, 1986] Richard Bogen. *MACSYMA reference manual*. Symbolics, Incorporated, 1986.
- [de Kleer and Brown, 1984] J. de Kleer and J. S. Brown. A qualitative physics based on confluences. *Artificial Intelligence*, 24(1):7–84, 1984. Also in: Bobrow, D. (ed.) *Qualitative Reasoning about Physical Systems* (North-Holland, Amsterdam, 1984 / MIT Press, Cambridge, Mass., 1985).
- [Fritzon, 2004] P. Fritzon. *Principles of Object-Oriented Modeling and Simulation with Modelica 2.1*. Wiley-IEEE Press, Piscataway, NJ, 2004.
- [Hinrichs *et al.*, 2011] Thomas R. Hinrichs, Kenneth D. Forbus, Johan de Kleer, Sungwook Yoon, Eric Jones, Robert Hyland, and Jason Wilson. Hybrid qualitative simulation of military operations. In Daniel G. Shapiro and Markus P. J. Fromherz, editors, *IAAI. AAI*, 2011.
- [Iwasaki *et al.*, 1995] Yumi Iwasaki, Adam Farquhar, Vijay Saraswat, Daniel Bobrow, and Vineet Gupta. Modeling time in hybrid systems: How fast is “instantaneous”? In *International Joint Conference on Artificial Intelligence*, volume 14, pages 1773–1781. Citeseer, 1995.
- [Klenk *et al.*, 2012] Matthew Klenk, Johan de Kleer, Daniel G. Bobrow, Sungwook Yoon, John Hanley, and Bill Janssen. Guiding and verifying early design using qualitative simulation. In *Proceedings of the ASME 2012 IDETC and CIE*, Chicago, IL, 2012.
- [Kuipers, 1994] Benjamin Kuipers. *Qualitative reasoning: modeling and simulation with incomplete knowledge*. MIT Press, Cambridge, MA, USA, 1994.
- [Kurtoglu and Campbell, 2009] Tolga Kurtoglu and Matthew I Campbell. Automated synthesis of electromechanical design configurations from empirical analysis of function to form mapping. *Journal of Engineering Design*, 20(1):83–104, 2009.
- [Nishida and Doshita, 1987] Toyooki Nishida and Shuji Doshita. Reasoning about discontinuous change. In *Proc. AAI*, volume 87, pages 643–648, 1987.
- [Otter *et al.*, 1999] Martin Otter, Hilding Elmqvist, and Sven Erik Mattsson. Hybrid modeling in modelica based on the synchronous data flow principle. In *Computer Aided Control System Design, 1999. Proceedings of the 1999 IEEE International Symposium on*, pages 151–157. IEEE, 1999.
- [Petzold, 1982] Linda R Petzold. Description of dassl: A differential/algebraic system solver. Technical report, Sandia National Labs., Livermore, CA (USA), 1982.
- [Sachenbacher and Struss, 2005] Martin Sachenbacher and Peter Struss. Task-dependent qualitative domain abstraction. *Artif. Intell.*, 162(1-2):121–143, 2005.
- [Simko *et al.*, 2012] Gabor Simko, Tihamer Levendovszky, Sandeep Neema, Ethan Jackson, Ted Bapty, Joseph Porter, and Janos Sztipanovits. Foundation for model integration: Semantic backplane. In *Proceedings of the ASME 2012 International Design Engineering Technical Conferences*

Figure 7: A subset of an environment in which an increasing torque causes a brake to start sliding. Ovals represent qualitative intervals and rectangles are qualitative instants. The cyan states correspond to the event triggered by the applied torque exceeding the maximum torque of the brake, and the yellow states correspond to the event triggered by the brake sliding.

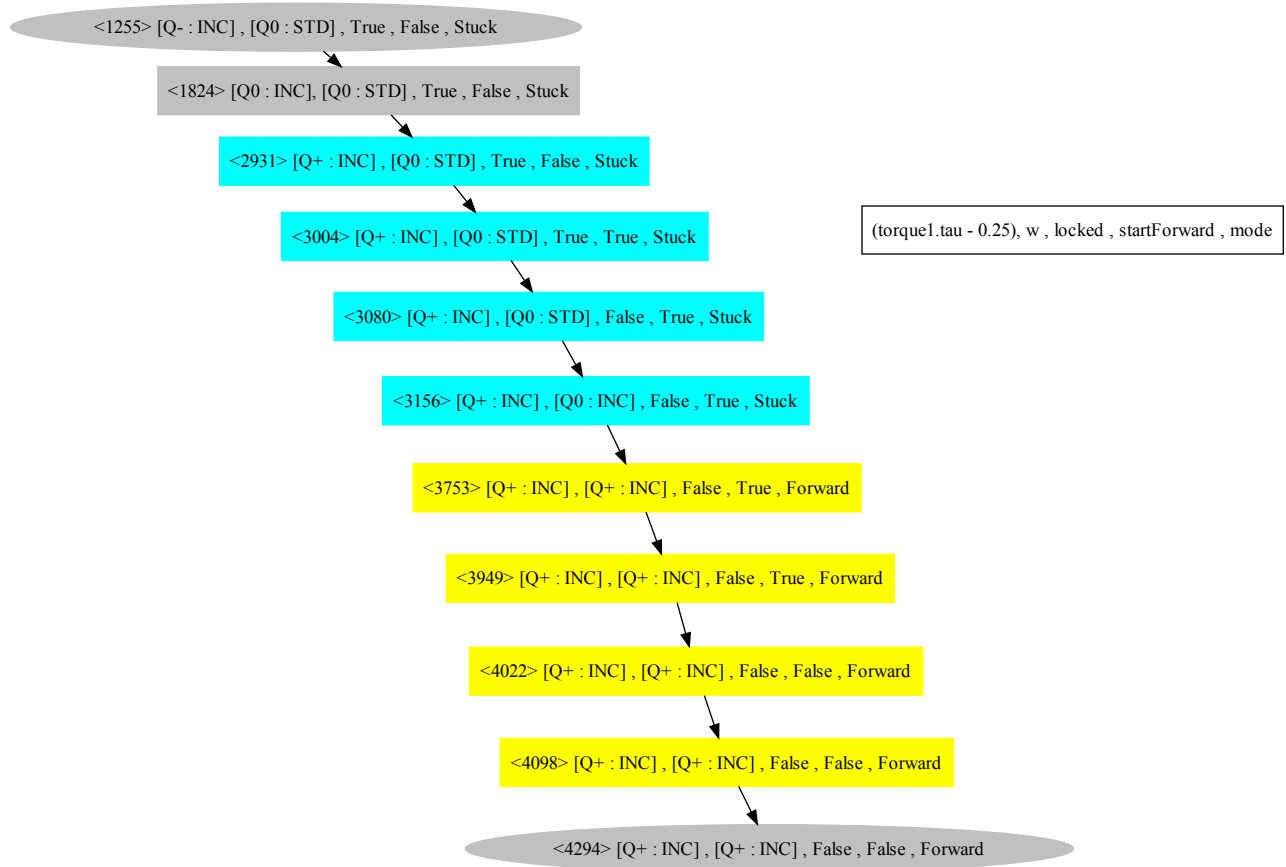

& Computers and Information in Engineering Conference
 IDETC/CIE, pages 12–15, 2012.

[Struss and Price, 2004] Peter Struss and Chris Price. Model-based systems in the automotive industry. *AI Magazine*, 24(4):17–34, 2004.

[Struss, 1988] P. Struss. Mathematical aspects of qualitative reasoning. *International Journal of Artificial Intelligence in Engineering*, 3(3), 1988.

[Weld and de Kleer, 1989] D.S. Weld and J. de Kleer. *Readings in Qualitative Reasoning about Physical Systems*. Morgan Kaufmann, 1989.

[Yılmaz and Say, 2006] Özgür Yılmaz and AC Cem Say. Causes of ineradicable spurious predictions in qualitative simulation. *Journal of Artificial Intelligence Research*, 27:551–575, 2006.

QUANTUM: Qualitative Abstractions of Non-polynomial Models *

William Denman

Computer Laboratory, University of Cambridge
United Kingdom
william.denman@cl.cam.ac.uk

Abstract

Dynamical systems modelled by differential equations that contain non-polynomial (sin, cos, exp, sqrt, etc.) terms are known to be difficult to analyse and simulate. This paper presents the qualitative abstraction framework QUANTUM, in which non-polynomial functions are used to abstract the continuous state space into a form that is amenable to formal verification. This is accomplished using the automated theorem prover MetiTarski.

1 Introduction

The *safety verification* of systems that reside in the physical world is a difficult problem. Models of real systems will more often than not include non-polynomial terms. For example, trigonometric functions can be used to relate angular velocity to position and the exponential function can be used to model certain types of friction. These *non-polynomial* or more generally *non-linear* systems do not usually admit an analytic or closed form solution. Because of this, verification of such systems rely mostly on numerical simulation.

For the simulation of dynamical systems, sets of input variables (parameters and initial conditions) are chosen, the simulation is run, and if the outputs match what is expected, the system is labeled *verified*. The issue here is that there could exist other sets of input conditions that have not been considered that will cause the system to fail. For infinite state systems that operate over \mathbb{R}^n , it is often impossible to test all combinations of inputs to the system in a reasonable amount of time.

Formal methods are a class of techniques based on logical theories that provide verification results valid for all possible inputs to a system. There are several well developed methods for verifying temporal properties of finite and infinite discrete transition systems. To apply these methods to dynamical systems, one common approach is to create a discrete abstraction that is a sound over-approximation of the original model.

Abstraction methods attempt to take a difficult problem and transform it into one that is more tractable. To reduce

the complexity of the physical model verification problem, QUANTUM lifts the non-polynomial system to a higher level of abstraction where continuous variables are replaced by conjunctions of abstract variables. By analyzing how these abstract variables change with respect to the concrete system's vector field, a sound discrete state abstraction is generated. This type of abstraction methodology has been successful for verifying polynomial dynamical systems. The key improvements presented in this paper are:

- The automated theorem prover MetiTarski is integrated as the decision procedure for proving the infeasibility of abstract states and determining abstract transitions.
- Non-polynomial Lyapunov functions are used to discretize the continuous state space.

The QUANTUM tool is one of only a handful available for dealing formally with non-polynomial dynamical systems.

MetiTarski [Akbarpour and Paulson, 2010] is an automated theorem prover for arithmetical conjectures involving first-order inequalities that contain transcendental functions. It has successfully proved theorems arising from the verification of analogue circuits [Denman *et al.*, 2009], linear hybrid systems [Akbarpour and Paulson, 2009] and aircraft stability [Denman *et al.*, 2011]. The most recent version of MetiTarski takes advantage of the non-linear solver within Z3 (SMT prover) for RCF decision calls, enabling proofs of non-linear systems containing up to 11 continuous variables. The advanced RCF decision procedures within Mathematica, that can handle transcendental functions directly, have also been integrated to aid in proofs containing equalities. The continued development of MetiTarski has contributed significantly to the success of the abstraction method described in this paper.

The abstraction algorithm implemented in QUANTUM is based on HybridSAL [Tiwari and Khanna, 2002]. The basic idea is to choose a finite collection P of smooth functions $p_i(x) : \mathbb{R}^n \rightarrow \mathbb{R}$ to split up the infinite state space into three qualitatively distinct regions. The abstraction function is $\alpha(p_i(x)) : (\mathbb{R}^n \rightarrow \mathbb{R})^i \rightarrow (pos, neg, zero)^i$ where

$$\begin{aligned} pos &= \{x \in \mathbb{R}^n \mid p_i(x) > 0\} \\ neg &= \{x \in \mathbb{R}^n \mid p_i(x) < 0\} \\ zero &= \{x \in \mathbb{R}^n \mid p_i(x) = 0\} \end{aligned}$$

*A preliminary report on this work appeared as "Abstracting Continuous Non-Polynomial Dynamical Systems", presented at the Imperial College Computing Student Workshop, September 2012.

Each abstract state is defined as a conjunction of (*pos, neg, zero*) for each $p_i(x)$ in P . The abstractions are guaranteed to be sound and relatively complete. Our results confirm that the completeness restriction does not limit the ability to prove safety properties of abstract models.

2 Related Work

Tiwari and Sankaranarayanan [Sankaranarayanan and Tiwari, 2011] have proposed a new type of hybrid system abstraction technique that summarizes the behaviour of the dynamics in each mode. This is accomplished by finding a *relational abstraction* of the type $R(x,y)$ that describe sets of states that flow from x to y along a continuous vector field. They take advantage of advanced techniques for generating positive invariants to abstract hybrid systems into infinite state systems. These abstractions are then verified using well-known techniques such as k-induction and Bounded Model Checking. Their techniques for generating the abstractions are not directly applicable to non-polynomial systems. However, for non-polynomial hybrid systems that contain some modes that are purely polynomial, relational abstractions could be combined with qualitative abstractions as both are just discrete state systems.

Sloth and Wisniewski [Sloth and Wisniewski, 2010; 2011] have developed a sound and complete method for abstraction of continuous systems using sub-level sets of Lyapunov functions. Each abstract region created by this process is positively invariant and can be used as a discrete state of a timed automaton. This allows the use of tools, such as UPPAAL [Larsen *et al.*, 1995] and KRONOS [Yovine, 1997], that can automatically check properties of timed automata. Time can always be added as an extra variable and therefore there is no need to use the timed automaton framework. Their techniques are only applicable to *Hirsch-Smale* systems that are guaranteed to have polynomial Lyapunov functions. Therefore their methods would not work on the examples in this paper. Many examples from their work can be solved analytically and MetiTarski has been successful at verifying them without the need for any form of abstraction.

An interesting alternative to reachability analysis is the logic-based deductive method for analyzing hybrid systems by Platzer [Platzer, 2010], who has developed a sound and relatively complete proof calculus for hybrid systems. Central to this work is a technique called *differential induction*, which allows reasoning about differential equations without having to solve them directly. It is essentially a way to formally reason about the qualitative behaviour of the system's vector field. The method developed by Platzer is very powerful and the applications are quite impressive. However he often relies on *differential axiomatization*, a type of re-casting where non-polynomial terms are replaced by using a change of co-ordinates. This re-casting is not applicable in general. MetiTarski has been integrated with KeYmaera to discharge proofs that contain the non-polynomial solutions of differential equations. The qualitative abstraction algorithm presented in this paper could potentially be combined with elements of differential induction.

Interval-based methods have also shown some promise for

non-linear hybrid system verification. Ishii *et al.* [Ishii *et al.*, 2011; 2009] have developed methods for the analysis of non-linear hybrid systems using what they call *hybrid constraint systems*. A non-linear ODE interval solver is used to enclose states with intervals where solutions are guaranteed to exist. They combine this method within an SMT framework to verify executions of the hybrid system. Similarly the work of Eggers *et al.* [Eggers *et al.*, 2011] use an interval-based solver combined with the iSAT algorithm.

The goal to combine formal methods such as model checking with qualitative reasoning is not new. One relevant example [Shults and Kuipers, 1997], proves temporal properties of the behaviour tree generated by the qualitative simulation algorithm QSIM. The verification results extend to the solutions of the original differential equations by the Guaranteed Coverage theorem that ensures the translation from ordinary differential equation to qualitative differential equation is sound. Qualitative phase-space analysis [Bernard and luc Gouz, 2002; Sacks, 1988], where non-linear systems are analysed based on their behaviour in different regions, is also similar to the ideas presented below. However, these methods are generally limited to polynomial systems and restricted subsets.

3 Preliminaries

A system can be modelled as a black box with a defined state and behaviour. The set of current values of the system's variables is its *state*. The *behaviour* is a function that defines how they will change with respect to time.

Definition 1 (Continuous Dynamical System). *Consider the state vector $x(t) \in \mathbb{R}^n$ and a smooth function $f : \mathbb{R}^n \rightarrow \mathbb{R}^n$. An n -dimensional continuous dynamical system is modelled by a set of ordinary differential equations (ODEs) of the form*

$$\dot{x}(t) = f(x(t)) \quad (1)$$

Ordinary indicates that the differential equations depend only on a single variable (time in this case) and its derivatives. If the functions $f(x)$ only contain polynomials, that is $f(x) = a_n x^n + a_{n-1} x^{n-1} + \dots + a_1 x + a_0$ where n is a non-negative integer and a_0, a_1, \dots, a_n are constants then the resulting system is polynomial. Otherwise the system is non-polynomial.

Definition 2 (Equilibrium Point). *A point in the state space \bar{x} is an equilibrium if and only if $f(\bar{x}) = 0$. The equilibrium point \bar{x} is stable if every trajectory starting within some region of \bar{x} , converges to \bar{x} .*

Lyapunov theory can be used to determine the stability of non-linear systems by searching for an energy-like function.

Definition 3 (Lyapunov Function). *A function $V(x)$ is a Lyapunov function, if for an equilibrium point (fixed point) located at the origin $(0,0)$ the following conditions hold*

$$V(x) > 0 \quad \text{for } x \neq 0 \quad (2a)$$

$$V(0) = 0 \quad (2b)$$

$$\frac{\partial V(x)}{\partial t} \leq 0 \quad \text{for all } x \quad (2c)$$

If a Lyapunov function exists, then the equilibrium point is guaranteed to be stable [Sastry, 1999]. The Lyapunov property is a sufficient condition for stability.

Example 1 (Pendulum). Consider the pendulum in Fig. 1. As a candidate Lyapunov function, take $V(x) = E$, the total energy (kinetic plus potential) of the system. When the pendulum is hanging straight down at position 0, the energy of the system will be zero, therefore $V(0) = 0$. To put energy into the system, the pendulum is lifted to certain height resulting in $V(x) > 0$. As the pendulum oscillates, the system continuously loses energy due to friction and therefore $V(x)$ is always decreasing, which implies that $\dot{V}(x) \leq 0$. Meeting the three conditions of Def. 3, $V(x)$ is an Lyapunov function and by definition the equilibrium point at rest is stable.

4 Abstraction of Real World Systems

To verify whether a dynamical system defined by a set of ordinary differential equations is safe, unsafe states must be unreachable. If the terms of the ODEs are linear, a closed form solution (trajectory) can be computed symbolically using a Computer Algebra System such as Mathematica. MetiTarski can then automatically verify for all initial conditions, that all trajectories will never enter any unsafe region. However, if non-polynomial terms are present, it is often impossible to obtain a closed form solution. This is true for even the simplest of systems.

Example 2 (Ideal Pendulum). Consider the friction-free pendulum in Fig. 1. A rod of length L is attached to a ball of mass m . As the ball swings, the angle θ between the rod and the vertical changes. The angular velocity (rotational speed in the tangential direction) $\omega(t)$ is equivalent to the change of the angle θ or $\frac{d\theta}{dt}$. Acceleration, velocity and position of the ball are related by $a = v' = x''$. The arc-distance traveled by the ball is $x = \theta L$. The effective force returning the ball to the centre is $mg \sin \theta$. The differential equations of the system can be derived from Newton's 2nd Law $F = ma$. Taking $\frac{F}{m} = a$, $a = x'' = (\theta L)'' = \omega' L$ gives the system in state space form

$$\theta' = \omega \quad (3a)$$

$$\omega' = -\frac{g}{L} \sin \theta \quad (3b)$$

The pendulum model is described by two simple differential equations, yet computing an exact analytic solution is not possible. Attempting to solve the system of equations (3) with Mathematica results in a solution that contains Jacobi elliptic functions that do not simplify to a closed form. This is a common occurrence with non-linear oscillators that contain non-polynomial terms.

4.1 Abstracting Continuous Non-Polynomial Systems

The theoretical foundation of the abstraction method is based on the one implemented in HybridSAL [Tiwari and Khanna, 2002; Tiwari, 2008]. The continuous state space of the dynamical system is discretized into a set of finite states using a set of functions P evaluated over the three domains (pos,

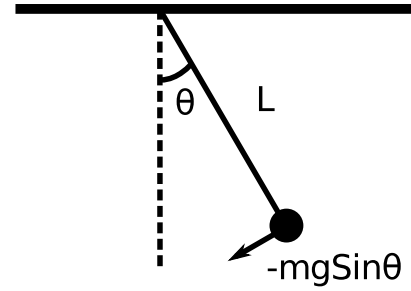

Figure 1: An ideal pendulum

zero, neg). Originally constrained to polynomial equations, the original methodology has been extended to work with non-polynomial terms. Using MetiTarski we can perform all parts necessary to complete the qualitative analysis. This includes both proving that certain abstract states are infeasible as well as determining transitions between abstract states.

From HybridSAL to QUANTUM

The QUANTUM abstraction method is presented in Algorithm 1 below. Starting in an initial state, the potential next states are found and the feasibility of each is checked. For the reachable states, the safety property is checked to hold. Once the new set of reachable states is equivalent to the previous set of reachable states, the process can stop. The output is a discrete transition system that holds for the safety property.

Calls to MetiTarski can potentially be expensive in terms of run-time, therefore the primary objective is to minimize the number of invocations. In HybridSAL, the sets of reachable states from each abstract state are fully constructed. In QUANTUM, the potential next states and feasibility are only checked if reachable from a previously feasible abstract state. This allows the algorithm to construct the abstraction on-the-fly while verifying safety properties on the model. This can drastically reduce the number of calls to MetiTarski and the total abstraction time.

Constructing the Discretizing Functions Set P

The first step of constructing the abstraction is choosing the functions that will discretize the state space. This choice will have a direct consequence on the difficulty level of constructing the abstract transition relation. It is not always obvious what will be a *good* discretizing function. The simplest starting choice is to use the definition of the system itself. The state variables of the system and the differential equations of the system can be used to construct the base set P .

Example 3 (Abstracting the Ideal Pendulum). Take the ideal pendulum with a rod of length 1, the vector field of this system is shown in Fig. 2a, with ω on the x -axis and θ on the y -axis. The initial set of abstracting functions is $P = \{\omega, \theta, -9.8 \sin \theta\}$.

Another set of functions that can be added to P arise from repeatedly taking the derivative of the terms of P . For certain types of linear systems, this process has been shown to terminate. This process can also be manually stopped. The manual termination will not affect the soundness of the process. Extra functions that are generated in this way will simply result

input : System of Ordinary Differential Equations
input : Initial Abstract State
input : Set of Discretizing Functions P
input : Safety Property
output: Discrete State System

```

while new-next-states != old-next-states:
    new-next-states = old-next-states;
    for state in new-next-states:
        if not checked-state(state):
            potential-states = find-next-states(state,P);
            for potential-state in potential-states:
                if state-is-feasible(potential-state):
                    if state-is-safe(potential-state):
                        new-next-states +=
                            potential-state;
                    else:
                        return "Abstraction Unsafe"
                else:
                    return "State not Feasible"
            else:
                return "Already Analyzed State"

```

Algorithm 1: QUANTUM Abstraction Loop

in a finer abstraction.

Example 4 (Further Abstraction Functions). *Starting with the base set $P = \{\omega, \theta, -9.8 \sin \theta\}$, the first second and third derivatives of $\dot{\omega}$ are symbolically computed and added to P . Resulting in $P = \{\omega, \theta, -9.8 \sin \theta, -9.8 \cos \theta \omega, -9.8(-9.8 \cos \theta \sin \theta - \sin \theta \omega^2), -9.8(-9.8 \cos \theta^2 \omega + 29.4 \omega \sin \theta^2 - \cos \theta \omega^3)\}$*

Lyapunov functions are a good source of discretizing functions because their sub-level sets form a positively invariant region. By definition, the solutions of a dynamical system will only pass through the level sets of Lyapunov functions in one direction. Alternatively, Lyapunov functions can be viewed as a barrier that separates different qualitative behaviour of the system. By adding sub-level sets of Lyapunov functions to P , the construction of the abstract transition relation, described below, will be simplified by limiting the possible reachable states.

The Lyapunov function $V(x)$ does not have to be an energy function. All that is required is that Def. 3 holds. The problem is that the search for Lyapunov functions is difficult. There are several methods based on sum-of-squares (SOS) techniques that make the search for the Lyapunov function tractable. These methods have been implemented in a MATLAB package called SOSTOOLS [Prajna *et al.*, 2004]. Sum-of-squares techniques are only directly applicable to polynomial systems. To use SOSTOOLS on a non-polynomial system it must be re-casted into a polynomial system and combined with algebraic constraints [Papachristodoulou and Prajna, 2005]. Barrier Certificates [Prajna, 2006], a generalization of Lyapunov functions, have been successfully used for the verification of polynomial hybrid systems [Prajna and Jadbabaie, 2004] and could also be a source of abstracting functions. This paper only considers Lyapunov functions.

Example 5 (Non-polynomial Lyapunov Function). *Re-casting the non-polynomial system to a polynomial one, take*

$u_1 = \sin(\theta), u_2 = \cos(\theta), \dot{u}_1 = \omega u_2, \dot{u}_2 = -\theta u_1$. *The re-casting process implies the algebraic constraint $u_1^2 + u_2^2 = 1$. The new polynomial system, along with the algebraic constraint are turned into a Sum-of-squares program and SOS-TOOLS finds that the equation $LF = 1.90844 \sin^2(\omega) + 1.90844 \cos^2(\omega) - 3.91687 \cos(\omega) + 0.19984\theta^2 + 0.00843192$ is a Lyapunov function of the system. Adding two level sets (0.3, and 7) of the Lyapunov function to P we get the abstract system shown in Fig. 2b.*

Initial States and Safety Property

Before the construction of the transition relation, the safety property to be verified must be initially converted into an abstract form over the abstract variables. Once transformed, this safety property should be added to the initial set P of discretizing functions.

In the case of the pendulum, the safety property to be verified is, “*if the ideal pendulum is oscillating, with no external input then it will never rotate*”. In the abstract system in Fig. 2b this is equivalent to asking if the system starts in State $S1$ it will never reach $S3$. These two qualitatively different regions determine the difference between oscillation and rotation. This concrete property is translated into a property over the base set of abstraction functions.

Example 6 (Pendulum Safety Property). *This safety property is abstracted to $(LF - 7 < 0)$. The final set of abstraction functions are $P = \{LF - 3, LF - 7, \omega, \theta, -9.8 \sin \theta, -9.8 \cos \theta \omega, -9.8(-9.8 \cos \theta \sin \theta - \sin \theta \omega^2), -9.8(-9.8 \cos \theta^2 \omega + 29.4 \omega \sin \theta^2 - \cos \theta \omega^3)\}$*

The initial states can then be chosen as any abstract state that hold under the safety property. For the pendulum example, $S1$ is chosen as the initial state.

Constructing the Transition Relation

Each abstract state is defined by a conjunction of the functions in P .

Example 7 (Abstract States). *Figure 2b, abstract state S_1 is represented by $(\omega > 0 \wedge \theta > 0 \wedge -9.8 \sin \theta > 0 \wedge \dots)$ and S_2 is $(\omega > 0 \wedge \theta < 0 \wedge -9.8 \sin \theta > 0 \wedge \dots)$.*

Assuming that the initial state is S , the first step is to determine all abstract transitions from S to the set of next states S' . MetiTarski is used to determine how the abstract states potentially flow along the vector field. Transitions between abstract states are determined by proving conjectures between the signs of the derivatives of the discretizing functions with respect to current abstract state.

Taking $\alpha(p_i(x))$ to represent the abstraction function $(\mathbb{R}^n \rightarrow \mathbb{R}) \rightarrow (pos, neg, zero)$. Each function in the conjunction defining state S is analysed in turn and the possible signs of the functions in the next state are returned, according to the algorithm find-next-states. p_i represents the i 'th abstraction function in the current state, p'_i the i 'th abstraction function in the next state.

The next step of constructing the transition relation is checking the feasibility of each of the potential next states. $\gamma(s) : (pos, neg, zero)^i \rightarrow \mathbb{R}^n$ is the concretization function from the abstract to the concrete domain. For an abstract state to be feasible there must exist a point in the real system that

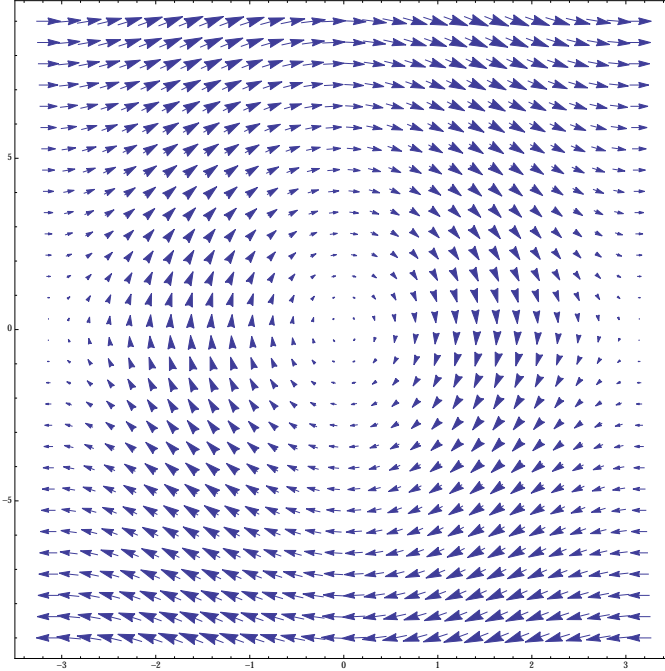

(a) Vector Field

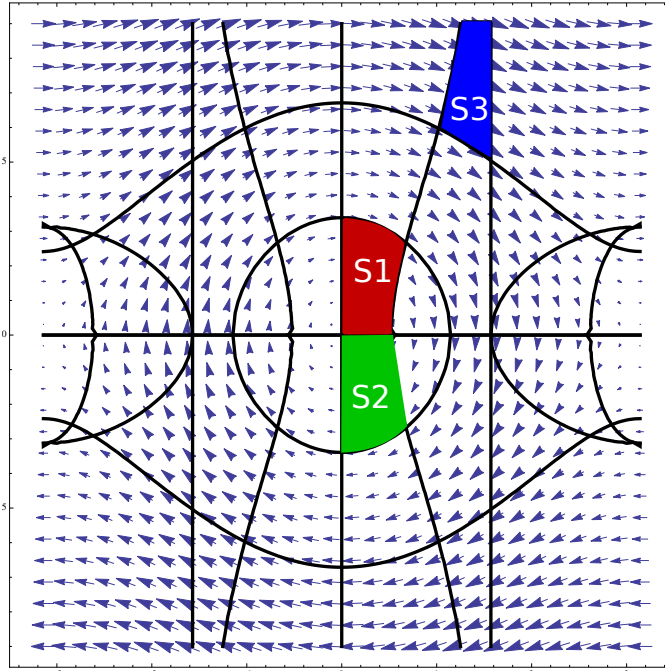

(b) Abstraction, with highlighted states S_1 , S_2 and S_3

Figure 2: The ideal pendulum

input : Abstract State S (Conjunction of Functions)

output: Sign conditions on Functions of P in S'

```

foreach  $p_i \in S$  do
  if  $\alpha(p_i) = pos$ :
    if  $\dot{p}_i \geq 0$ :
       $\alpha(p'_i) = pos \in S'$ 
    else:
       $(\alpha(p'_i) = pos \vee \alpha(p'_i) = zero) \in S'$ 
  elif  $\alpha(p_i) = neg$ :
    if  $\dot{p}_i \leq 0$ :
       $\alpha(p'_i) = neg \in S'$ 
    else:
       $(\alpha(p'_i) = neg \vee \alpha(p'_i) = zero) \in S'$ 
  else:
    if  $\dot{p}_i \geq 0 \wedge \dot{p}_i = 0$ :
       $\alpha(p'_i) = pos \in S'$ 
    elif  $\dot{p}_i \leq 0 \wedge \dot{p}_i = 0$ :
       $\alpha(p'_i) = neg \in S'$ 
    elif  $\dot{p}_i \leq 0 \wedge \dot{p}_i \geq 0$ :
       $\alpha(p'_i) = zero \in S'$ 
    else:
       $(\alpha(p'_i) = neg \vee \alpha(p'_i) = zero \vee \alpha(p'_i) = pos) \in S'$ 

```

Algorithm 2: find-next-states

satisfies the concretization function. For state S to be feasible there must $\exists S : \gamma(S) \simeq \exists x : (p_1(x) \wedge p_2(x) \wedge \dots \wedge p_i(x))$

Because of implementation details (that are beyond the scope of this paper), MetiTarski can only prove the simplest of existential conjectures. The feasibility check must be turned into a universally quantified formula. The conjecture to prove is now $\forall x : \neg(p_0(x) \wedge p_1(x) \wedge \dots \wedge p_i(x))$ which implies $\nexists x : (p_0(x) \wedge p_1(x) \wedge \dots \wedge p_n(x))$. If this conjecture is proved then we know that state S' is infeasible. Even though the abstraction procedure (and the method behind MetiTarski) is categorically incomplete, the states that cannot be proved to be infeasible are assumed to be feasible. By doing so, infeasible states might be included in the abstraction. Fortunately, this assumption does not affect soundness and will only result in an overall coarser abstraction.

Verification

Once the abstraction loop has generated the set of feasible states and the transitions between them, it is then possible to apply formal verification methods, such as Symbolic Model Checking [Clarke *et al.*, 1996], to the resulting discrete state transition system. The idea behind Model Checking is to determine whether some finite state machine M models a temporal property p , written as $M \models p$. It can be thought of an automatic method for traversing the state graph, checking whether the property holds for each state.

5 Experimental Results

A series of experiments were performed using QUANTUM on the ideal pendulum example described in this paper. Each experiment used a different number of abstraction functions to discretize the state space. The experiments began by

Experiment	Func	Feasible	Infeasible	Proved Trans	Unproved Trans	Abs. Time (s)
simplePend-10	(3,0)	20	7	28	52	5
simplePend-100	(3,0)	20	7	39	44	7
simplePend-1000	(3,0)	20	7	41	34	54
simplePend2-10	(5,0)	121	122	512	363	71
simplePend2-100	(5,0)	121	122	551	328	125
simplePend2-1000	(5,0)	121	122	569	225	431
simplePend3-10	(4,1)	136	107	745	680	110
simplePend3-100	(4,1)	136	107	827	636	213
simplePend3-1000	(4,1)	136	107	937	371	1167
simplePend4-10	(3,2)	139	104	278	775	114
simplePend4-100	(3,2)	139	104	291	771	243
simplePend4-1000	(3,2)	139	104	574	489	1549

Table 1: Pendulum Experimental results

choosing a small number of discretizing functions and successively constructing finer abstractions by including more functions and increasing the timeout to MetiTarski.

The results from the series of experiments are shown in Table 1. Each line represents one separate experiment. The name of each experiment ends with a number representing the timeout in milliseconds given to MetiTarski. “Func” is a tuple representing the total number of abstraction functions (ith derivative, sub-level Lyapunov set). “Feasible” and “Infeasible” are respectively the total number of feasible and infeasible states in the final abstraction. “Proved Trans” and “Unproved Trans” respectively represent the number of proved and unproved transitions of the abstract model. “Abs. Time” is total amount of time QUANTUM takes to construct the abstraction.

The results demonstrate two important facts. MetiTarski is extremely good at checking the infeasibility of states. Lengthening the timeout does not make a significant difference to the number of feasible states of the system. On the other hand, for proving transitions, the results indicate that longer timeouts will result in more transitions being proved. This comes at the cost of increasing the total abstraction time.

Implementation Details

The experiments were performed on a 2.6 GHz Intel Core i7 with 8GB of RAM. The abstraction algorithm was implemented in Python 2.7, using SymPy 0.7.2 [SymPy Development Team, 2012] to perform all symbolic differentiation. The current development version of MetiTarski¹ was used for all abstract model construction. The source code for the abstraction algorithm, along with the NuSMV files, MetiTarski proofs and all other relevant files are located online².

6 Conclusion

Presented in this paper is a qualitative abstraction method for handling non-polynomial dynamical systems. The results show that QUANTUM can be used for creating a discrete

state abstraction in a reasonable amount of time. The automated theorem prover MetiTarski plays a significant role in determining the feasibility of abstract states and abstract transition relations.

There are several ways the efficiency of the abstraction process could be improved. During feasibility checking of abstract states either MetiTarski returns quickly or not at all. By implementing several passes of the check in increasing timeout increments, the time wasted on unprovable conjectures will be reduced significantly. Caching abstractions between separate verification goals will allow one abstraction to be the seed of the next, removing the need for repeated full feasibility checks. Refinement of the transition relations will also benefit from caching as only specific problem states (those with many transitions) can be isolated and checked with a higher timeout.

We have demonstrated the novel use of non-polynomial Lyapunov functions, which have only previously been used for proving the stability of dynamical systems. However to take advantage of them for the verification of hybrid systems, multiple Lyapunov functions that are valid in each discrete mode must be found. A Sum-of-squares solution using SOS-TOOLS could be used to address this problem.

Many of the formal methods for abstracting and verifying continuous and hybrid systems share ideas similar in spirit to those in the qualitative reasoning community. In particular, the abstraction method described in this paper can be seen as one type of semi-quantitative simulation. Scaling novel methods has always been a serious bottleneck for both communities. Qualitative abstraction combined with a state-of-the-art theorem prover shows great potential for jumping over this common hurdle.

7 Acknowledgements

The research was supported by the Engineering and Physical Sciences Research Council [grant numbers EP/I011005/1, EP/I010335/1]

¹<http://code.google.com/p/metitarski/>

²<http://www-dyn.cl.cam.ac.uk/~wd239/quantum>

References

- [Akbarpour and Paulson, 2009] B. Akbarpour and L. C. Paulson. Applications of MetiTarski in the verification of control and hybrid systems. In *Hybrid Systems: Computation and Control*, volume 5469 of *Lecture Notes in Computer Science*, pages 1–15, 2009.
- [Akbarpour and Paulson, 2010] Behzad Akbarpour and Lawrence C. Paulson. MetiTarski: An automatic theorem prover for real-valued special functions. *Journal of Automated Reasoning*, 44:175–205, 2010.
- [Bernard and luc Gouz, 2002] Olivier Bernard and Jean luc Gouz. Global qualitative description of a class of nonlinear dynamical systems. *Artificial Intelligence*, 136:29–59, 2002.
- [Clarke et al., 1996] E. Clarke, K. McMillan, S. Campos, and V. Hartonas-Garmhausen. Symbolic model checking. In *Computer Aided Verification*, volume 1102 of *Lecture Notes in Computer Science*, pages 419–422. Springer, 1996.
- [Denman et al., 2009] W. Denman, B. Akbarpour, S. Tahar, M. H. Zaki, and L. C. Paulson. Formal verification of analog designs using MetiTarski. In *Formal Methods in Computer-Aided Design. FMCAD 2009*, pages 93–100, November 2009.
- [Denman et al., 2011] William Denman, Mohamed H. Zaki, Sofiène Tahar, and Luis Rodrigues. Towards flight control verification using automated theorem proving. In *NASA Formal Methods*, pages 89–100, 2011.
- [Eggers et al., 2011] Andreas Eggers, Nacim Ramdani, Nedialko Nedialkov, and Martin Fränzle. Improving sat modulo ode for hybrid systems analysis by combining different enclosure methods. In *Software engineering and formal methods, SEFM’11*, pages 172–187, Berlin, Heidelberg, 2011. Springer-Verlag.
- [Ishii et al., 2009] Daisuke Ishii, Kazunori Ueda, Hiroshi Hosobe, and Alexandre Goldsztejn. Interval-based solving of hybrid constraint systems. In *Analysis and Design of Hybrid Systems, ADHS’09*, pages 144–149, 2009.
- [Ishii et al., 2011] Daisuke Ishii, Kazunori Ueda, and Hiroshi Hosobe. An interval-based sat modulo ode solver for model checking nonlinear hybrid systems. *Int. J. Softw. Tools Technol. Transf.*, 13(5):449–461, October 2011.
- [Larsen et al., 1995] Kim G. Larsen, Johan Bengtsson, Johan Bengtsson, Kim Larsen, Fredrik Larsson, Fredrik Larsson, Paul Pettersson, Paul Pettersson, Wang Yi, and Wang Yi. Uppaal - a tool suite for automatic verification of real-time systems. In *Hybrid Systems III, LNCS 1066*, pages 232–243. Springer-Verlag, 1995.
- [Papachristodoulou and Prajna, 2005] Antonis Papachristodoulou and Stephen Prajna. Analysis of non-polynomial systems using the sum of squares decomposition. In Didier Henrion and Andrea Garulli, editors, *Positive Polynomials in Control*, volume 312 of *LNCIS*, pages 23–43. Springer Berlin Heidelberg, 2005.
- [Platzer, 2010] Andre Platzer. *Logical Analysis of Hybrid Systems*. Springer, 2010.
- [Prajna and Jadbabaie, 2004] Stephen Prajna and Ali Jadbabaie. Safety verification of hybrid systems using barrier certificates. In *In Hybrid Systems: Computation and Control*, pages 477–492. Springer, 2004.
- [Prajna et al., 2004] Stephen Prajna, Antonis Papachristodoulou, Peter Seiler, and Pablo A. Parrilo. SOSTOOLS: Sum of squares optimization toolbox for MATLAB, 2004.
- [Prajna, 2006] Stephen Prajna. Barrier certificates for nonlinear model validation. *Automatica*, 42(1):117–126, 2006.
- [Sacks, 1988] Elisha Sacks. *Automatic Qualitative Analysis of Ordinary Differential Equations Using Piecewise Linear Approximations*. PhD thesis, Massachusetts Institute of Technology, 1988.
- [Sankaranarayanan and Tiwari, 2011] Sriram Sankaranarayanan and Ashish Tiwari. Relational abstractions for continuous and hybrid systems. In *Computer aided verification, CAV’11*, pages 686–702, Berlin, Heidelberg, 2011. Springer-Verlag.
- [Sastry, 1999] Shankar Sastry. *Nonlinear Systems*. Springer, 1999.
- [Shults and Kuipers, 1997] Benjamin Shults and Benjamin J. Kuipers. Proving properties of continuous systems: Qualitative simulation and temporal logic. *ARTIFICIAL INTELLIGENCE*, 92:91–129, 1997.
- [Sloth and Wisniewski, 2010] C. Sloth and R. Wisniewski. Abstraction of continuous dynamical systems utilizing lyapunov functions. In *Decision and Control (CDC), 2010 49th IEEE Conference on*, pages 3760–3765, December 2010.
- [Sloth and Wisniewski, 2011] Christoffer Sloth and Rafael Wisniewski. Verification of continuous dynamical systems by timed automata. *Form. Methods Syst. Des.*, 39(1):47–82, August 2011.
- [SymPy Development Team, 2012] SymPy Development Team. *SymPy: Python library for symbolic mathematics*, 2012.
- [Tiwari and Khanna, 2002] Ashish Tiwari and Gaurav Khanna. Series of abstractions for hybrid automata. In *Hybrid Systems: Computation and Control HSCC*, volume 2289 of *LNCS*, pages 465–478. Springer, March 2002.
- [Tiwari, 2008] Ashish Tiwari. Abstractions for hybrid systems. *Form. Methods Syst. Des.*, 32(1):57–83, February 2008.
- [Yovine, 1997] Sergio Yovine. Kronos: A verification tool for real-time systems. (kronos user’s manual release 2.2). *International Journal on Software Tools for Technology Transfer*, 1:123–133, 1997.

A logic-based approach for qualitative sum and product

Alfredo Burrieza, Emilio Muñoz-Velasco, and Manuel Ojeda-Aciego
University of Málaga (Spain)

Abstract

We formalize the notions of *qualitative sum* and *qualitative product* in order to obtain a multimodal logic approach for order of magnitude reasoning which manages directly both qualitative operations. We use these qualitative operations to define the notions of *negligibility* and *closeness*. Some of the advantages of our approach are shown on the basis of examples.

1 Introduction

Human beings do not need to have a lot of quantitative information in order to make decisions or doing their normal tasks. In fact, in many cases, the use and abuse of quantitative information, may cause what is called *infobesity*, which could obstruct the reasoning process. Qualitative Reasoning (QR), can help to manage situations where incomplete information is involved, or the quantitative values are not available or necessary. QR has been successfully applied to many different areas [4] such as autonomous space-craft support, failure analysis and on-board diagnosis of vehicle systems, automated generation of control software for photocopiers, and intelligent aids for learning about thermodynamic cycles, etc. Many papers have been published in the last thirty years about QR, from [11; 3; 31; 10; 18; 12], until recent applications such as [17; 15; 16; 25], among others.

Our research is focused on a part of QR called *order of magnitude reasoning* [24; 1; 29], which combines an *absolute* part, where the values are divided into different qualitative classes such as *small*, *medium* and *large* (positive and negative), together with *zero*; and a *relative* approach where notions as *closeness* and *negligibility* [24] are considered. In fact, we have been studying different logics for order of magnitude reasoning [5; 6; 7; 14] and its applications to moving objects such as robots.

The use of logic in QR has many advantages, namely, logic provides a formal language for expressing and reasoning within QR which avoids many case-based situations. Moreover, logic provides the possibility of making automated reasoning, for instance, for proving the validity of a formula or the satisfiability of a formula in a specific model.

More specifically, the use of a logic-based approach with qualitative arithmetic operations allows for incorporating natural language into arithmetics, in order to express notions such as closeness and negligibility, among others; that is, with our logic-based approach we can express not only the arithmetic operations given by the tables, but also other properties of the physical systems which are not directly expressible from arithmetic tables.

There are in the literature different logic approaches based on QR. For instance, [2] focuses on Qualitative Spatial and Temporal Reasoning and [27] is centered on reasoning about topology and relative distance in metric and more general distance spaces, just to name a few of the recent ones. On the other hand, arithmetic operations in qualitative reasoning have been considered, for instance, in [9; 19; 30; 23], in order to deal with algebraic and differential equations for modelling purposes, from Robotics [20] to Ecology [16].

In this paper, we formalize the notions of *qualitative sum* and *qualitative product* by constructing a logic to deal with these arithmetic operations. We divide the real line into 11 qualitative classes, adapting the division into 7 qualitative classes, presented for instance in [26], to our specific approach. This election of qualitative classes may be changed easily depending on the problem in question. We use the qualitative operations to define also the notions of *negligibility* and *closeness*. As far as we know, this is the first multimodal logic approach for order of magnitude reasoning which manages directly both qualitative operations of sum and product.

The paper is organized as follows: Section 2 introduces we use the intrinsic properties of the qualitative approach in order to obtain the tables for qualitative sum and product. Section 3 presents the logic for qualitative sum: syntax and semantics together with some examples showing the applicability of our logic approach. Finally, some conclusions and prospects of future work are discussed in Section 4.

2 Qualitative sum and product

We consider a linearly ordered set $(\mathbb{S}, <)$ divided into 11 qualitative classes using five landmarks chosen depending on the context [22; 28]. The system considered corresponds to the schematic representation shown below:

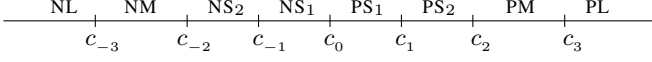

where $c_i \in \mathbb{S}$ for $i \in \{-3, -2, -1, 0, 1, 2, 3\}$ such that they satisfy $c_j < c_{j+1}$ for all $j \in \{-3, -2, -1, 0, 1, 2\}$.

We consider the following set of qualitative classes:

$$\begin{aligned} \text{NL} &= (\leftarrow, c_{-3}), & \text{NM} &= [c_{-3}, c_{-2}), \\ \text{NS}_2 &= [c_{-2}, c_{-1}), & -1 &= \{c_{-1}\}, & \text{NS}_1 &= (c_{-1}, c_0), \\ & & 0 &= \{c_0\} \\ \text{PS}_1 &= (c_0, c_1), & 1 &= \{c_1\}, & \text{PS}_2 &= (c_1, c_2], \\ \text{PM} &= (c_2, c_3], & \text{PL} &= (c_3, \rightarrow) \end{aligned}$$

The labels correspond to “negative large”, “negative medium”, “negative small smaller than -1”, “-1”, “negative small greater than -1”, “zero”, “positive small smaller than 1”, “1”, “positive small greater than 1”, “positive medium” and “positive large”, respectively.

We consider the elements 1, -1 in order to represent the neutral element of the qualitative product and its opposite, respectively. Notice that the introduction of the qualitative class representing 1 (similarly for -1), divides the positive small numbers into two qualitative classes PS_1 and PS_2 , which will be important in order to define the qualitative product. As a consequence, we define the following sets $\text{PS} = \text{PS}_1 \cup 1 \cup \text{PS}_2$. Moreover, for simplicity in the presentation, we define also $\text{P} = \text{PS} \cup \text{PM} \cup \text{PL}$, and $\text{P}_2 = \text{PS}_2 \cup \text{PM} \cup \text{PL}$. Similarly, we define NS , N , and N_2 .

As usual in this type of approach [26], we consider \mathbb{S} to be the real line, define $c_{-n} = -c_n$ for $n \in \{1, 2, 3\}$, and assume $c_3 \geq 2c_2$. The latter restriction (actually, necessary just for the cases $\text{NL} + \text{PS}$, $\text{NS} + \text{NS}$, and $\text{NS} + \text{PL}$) justifies our abstract definition of qualitative sum given in¹ Table 1. For instance, the table states that if we sum a negative medium number with a positive large, we obtain a positive number, either small, or medium or large. Notice that in our approach, we distinguish two types of (positive and negative) small numbers, depending on whether they are smaller or greater than c_1 . This is very useful to define the Table 2 for qualitative product.

In order to give a multimodal logic approach, we will represent qualitative sum and product in terms of relations. The intuitive idea is to formalize statements like *adding a small positive number* in terms of a relation $+_{\text{PS}}$ defined by $(x, y) \in +_{\text{PS}}$ understood as y is obtained from x by adding a positive small number. Similarly, $(x, y) \in *__{\text{NL}}$ means that y is obtained from x by multiplying a negative large number.

We formalize the previous ideas in the following two definitions.

¹For readability, we have filled-in just half of the entries, the blank ones follow by commutativity.

Definition 1 We say that a set of relations $\mathcal{R}^+ = \{+_{\text{NL}}, +_{\text{NM}}, +_{\text{NS}}, +_0, +_{\text{PS}}, +_{\text{PM}}, +_{\text{PL}}\}$, is **adequate for the qualitative sum** if the following conditions hold:

1. The relations satisfy² Table 1.
2. $+_0 = \{(x, x) \mid x \in \mathbb{S}\}$.
3. If $Q \neq Q'$, then $+_Q \cap +_{Q'} = \emptyset$.
4. For all $x, y \in \mathbb{S}$, $x < y$ iff $(x, y) \in +_{\text{P}}$ for some $\text{P} \in \{\text{PS}, \text{PM}, \text{PL}\}$.
5. For all $x, y \in \mathbb{S}$, $(x, y) \in +_Q$ iff $(y, x) \in +_{\bar{Q}}$

where if Q is NL (resp. $\text{NM}, \text{NS}, 0, \text{PS}, \text{PM}, \text{PL}$), then the opposite \bar{Q} is PL (resp. $\text{PM}, \text{PS}, 0, \text{NS}, \text{NM}, \text{NL}$).

Similarly, we define the corresponding concept for the qualitative product.

Definition 2 We say that a set of relations $\mathcal{R}^* = \{*__{\text{NL}}, *__{\text{NM}}, *__{\text{NS}_2}, *__{-1}, *__{\text{NS}_1}, *_0, *__{\text{PS}_1}, *_1, *__{\text{PS}_2}, *__{\text{PM}}, *__{\text{PL}}\}$, is **adequate for the qualitative product** if the following conditions hold:

1. The relations satisfy Table 2.
2. $*_1 = \{(x, x) \mid x \in \mathbb{S}\}$.
3. If $Q_1 \neq Q_2$, then $*_{Q_1} \cap *_{Q_2} = \emptyset$.
4. For all $x, y \in \mathbb{S}$, if $x < y$ then $(x, y) \in *_Q$ for some Q .
5. For all $x, y \in \mathbb{S}$, and $Q \neq 0$, then $(x, y) \in *_Q$ iff $(y, x) \in *_{Q'}$

where if $Q \in \{\text{NL}, \text{NM}, \text{NS}_2\}$, then the inverse Q' is NS_1 . Analogously, if $Q \in \{\text{PL}, \text{PM}, \text{PS}_2\}$, then the inverse Q' is PS_1 . Moreover, the inverse of -1 (resp. $\text{NS}_1, \text{PS}_1, 1$) is -1 (resp. $\text{N}, \text{P}, 1$).

Notice that Table 2 and the definition of inverse above implies the obvious definition of qualitative quotient of two classes as the qualitative product of an element by its inverse.

We will say that $\mathcal{R} = \mathcal{R}^+ \cup \mathcal{R}^*$ is an **adequate set of relations** for \mathbb{S} whenever \mathcal{R}^+ is adequate for the quantitative sum and \mathcal{R}^* is adequate for the quantitative product.

The previous definitions allow us to introduce the concepts of closeness and negligibility as follows:

Definition 3 Given an adequate set of relations on \mathbb{S} and $x, y \in \mathbb{S}$, we say that x is **close** to y , denoted by $x\mathcal{C}y$, iff either $x = y$, or $(x, y) \in +_{\text{PS}}$, or $(x, y) \in +_{\text{NS}}$.

Definition 4 Given an adequate set of relations on \mathbb{S} and $x, y \in \mathbb{S}$, we say that x is **negligible** wrt y , denoted by $x\mathcal{N}y$, iff either $(x, y) \in +_{\text{PL}} \circ +_{\text{PL}}$, or $(x, y) \in +_{\text{NL}} \circ +_{\text{NL}}$, where \circ represents the composition of relations.

Let us consider now two examples to explain how the tables presented work.

²For instance, the entry for $\text{NL} + \text{PS}$ holds if and only if $(x, y) \in +_{\text{NL}}$ and $(y, z) \in +_{\text{PS}}$, then either $(x, z) \in +_{\text{NL}}$ or $(x, z) \in +_{\text{NM}}$; and similarly for the rest of the entries.

Table 1: Definition of qualitative sum

+	NL	NM	NS	0	PS	PM	PL
NL	NL	NL	NL	NL	NL ∪ NM	N	§
NM		NL ∪ NM	NL ∪ NM	NM	NM ∪ NS	NM ∪ NS ∪ 0 ∪ PS ∪ PM	P
NS			NM ∪ NS	NS	NS ∪ 0 ∪ PS	PS ∪ PM	PM ∪ PL
0				0	PS	PM	PL
PS					PS ∪ PM	PM ∪ PL	PL
PM						PM ∪ PL	PL
PL							PL

Table 2: Definition of qualitative product

*	NL	NM	NS ₂	-1	NS ₁	0	PS ₁	1	PS ₂	PM	PL
NL	PL	PL	PL	PL	P	0	N	NL	NL	NL	NL
NM		PM ∪ PL	PM ∪ PL	PM	PS ∪ PM	0	NM ∪ NS	NM	NL ∪ NM	NL ∪ NM	NL
NS ₂			P ₂	PS ₂	PS	0	NS	NS ₂	N ₂	NL ∪ NM	NL
-1				1	PS ₁	0	NS ₁	-1	NS ₂	NM	NL
NS ₁					PS ₁	0	NS ₁	NS ₁	NS	NM ∪ NS	N
0						0	0	0	0	0	0
PS ₁							PS ₁	PS ₁	PS	PS ∪ PM	P
1								1	PS ₁	PM	PL
PS ₂									P ₂	PM ∪ PL	PL
PM										PM ∪ PL	PL
PL											PL

Example 1 Let us consider the Michaelis-Menten kinetics and the different modes of inhibition of an enzymatic reaction [1]. Notice that all the parameters considered are positive. In the case of competitive inhibition, the kinetic analysis of isolated enzymatic reaction is described by the following equation (see [21] for more details):

$$\frac{r}{V} = \frac{K_i \cdot A}{K_i \cdot A + K_m \cdot (K_i + B)} \quad (1)$$

where A, K_m, B, K_i, r and V denote the substrate, the Michaelis constant, the inhibitor, the inhibition constant, the rate of biochemical reaction and the maximum enzyme turnover respectively.

As explained in [21], if we assume different order of magnitude relations between the elements of the equation. Our logic approach allows us to reason by using our general tables for qualitative sum and product and some specific formulas. For instance, if we assume:

$$A \in \text{PS}; \quad B \in \text{PS}; \quad K_i \in \text{PS}; \quad K_m \in \text{PL}$$

then we can deduce from Tables 1 and 2 that

$$\frac{r}{V} \in \text{PS}$$

which means that $\frac{r}{V}$ is a small number, hence we can deduce that r is small compared to V . Many similar inferences can be made by using our logic approach without using case-based tables.

Example 2 The following example is given in [8]. Let us consider the following qualitative differential equations are

considered in order to represent the displacement of a heavy block on a spring:

$$x' = v; \quad v' = -\frac{x}{\text{LARGE}} \quad (2)$$

where x be the displacement of the block from its rest point, v its velocity. We now give the first step in the sequence of qualitative states consistent with (2).

We start with the block at some finite displacement and zero velocity. That is, in the first state, we will have:

$$x \in \text{PM}; \quad v \in 0$$

From the differential equations, and using our tables for qualitative sum and product, we deduce:

$$v \in 0; \quad v' \in \text{NS}$$

By variance bound, Δv must be 0. By variance over time, therefore, $\Delta T = \Delta v = v' = 0$. Applying variance over time in the other direction, $\Delta x = \Delta T \cdot x' = 0$. So we have a complete description of the first state:

$$x \in \text{PM}; \quad x' \in 0; \quad \Delta x \in 0$$

$$v \in 0; \quad v' \in \text{NS} \quad \Delta v \in 0; \quad \Delta T \in 0$$

As in the previous state it holds $v \in 0$ and $v' \in \text{NS}$, we have in the following state that $v \in \text{NS}$. Using the equations (2), and our tables for qualitative operations, we deduce $x' \in \text{NS}$ and $v' \in \text{NS}$.

For the next state, if we assume $x \in \text{PS}$ then we obtain similarly as in the previous cases, that $x' \in \text{NS}$ and $v' \in \text{NS}$.

As a consequence $\Delta X \in \text{PSUPM}$ and, therefore, $\Delta T = \frac{\Delta X}{|X'|}$ verifies:

$$\Delta T \in \text{PM} \cup \text{PL}$$

Finally, we conclude that any path which brings the block to its rest point includes a state whose duration is medium or large.

3 The logic $\mathcal{L}(OM)^{+*}$ for qualitative sum

To begin with, let us informally define the meaning of the modal connectives we will consider in our language. The intuitive meaning of the modalities of $\mathcal{L}(OM)^{+*}$ are given below, for any formula A .

- $\square_{+Q}A$ means A is true for all points obtained by adding to the current one any element of class Q , where $Q \in \{\text{NL}, \text{NM}, \text{NS}, 0, \text{PS}, \text{PM}, \text{PL}\}$.
- $\square_{*Q}A$ means A is true for all points obtained by adding to the current one any element of class Q , where $Q \in \{\text{NL}, \text{NM}, \text{NS}_2, -1, \text{NS}_1, 0, \text{PS}_1, 1, \text{PS}_2, \text{PM}, \text{PL}\}$.

For instance, $\square_{+\text{PS}}A$ means A is true for all points obtained by adding to the current one any element of class PS , that is, any positive small number. Similarly, $\square_{*\text{PM}}A$ means A is true for all points obtained by multiplying to the current one any element of class PM .

The syntax of our logic is the usual modal propositional language on the modalities described above and a set of specific constants to denote the qualitative classes. Formally, the alphabet of our language is defined by using:

- A stock of atoms or propositional variables, \mathcal{V} .
- The classical connectives $\neg, \wedge, \vee, \rightarrow$ and the constant symbols \top and \perp .
- The unary modal connectives \square_{+Q} , for every $Q \in \{\text{NL}, \text{NM}, \text{NS}, 0, \text{PS}, \text{PM}, \text{PL}\}$.
- The unary modal connectives \square_{*Q} , for every $Q \in \{\text{NL}, \text{NM}, \text{NS}_2, -1, \text{NS}_1, 0, \text{PS}_1, 1, \text{PS}_2, \text{PM}, \text{PL}\}$.
- The finite set of formulas representing the qualitative classes³

$$\{\text{nl}, \text{nm}, \text{ns}_2, -1, \text{ns}_1, 0, \text{ps}_1, 1, \text{ps}_2, \text{pm}, \text{pl}\}$$

- The auxiliary symbols $(,)$.

The well-formed formulae of $\mathcal{L}(OM)^{+*}$ are generated by the construction rules of classical propositional logic on the set $\mathcal{V} \cup \{\text{nl}, \text{nm}, \text{ns}_2, -1, \text{ns}_1, 0, \text{ps}_1, 1, \text{ps}_2, \text{pm}, \text{pl}\}$ plus the following rule which introduces the modal connectives:

If A is a formula, then so is $\square_{+Q}A, \square_{*Q}A$, for all Q .

As usual, the existential $\diamond_{+Q}, \diamond_{*Q}$ are the abbreviation of $\neg \square_{+Q} \neg, \neg \square_{*Q} \neg$, respectively. Moreover, we define ps as the abbreviation of $\text{ps}_1 \vee 1 \vee \text{ps}_2$, and ns as the abbreviation of $\text{ns}_2 \vee -1 \vee \text{ns}_1$

Some other defined connectives are given below, together with their corresponding existential connectives:

- $\overline{\square}A \stackrel{\text{def}}{=} \square_{+\text{PS}}A \wedge \square_{+\text{PM}}A \wedge \square_{+\text{PL}}A$
- $\overleftarrow{\square}A \stackrel{\text{def}}{=} \square_{+\text{NS}}A \wedge \square_{+\text{NM}}A \wedge \square_{+\text{NL}}A$
- $\square_C A \stackrel{\text{def}}{=} \square_{+\text{NS}}A \wedge A \wedge \square_{+\text{PS}}A$
- $\square_N A \stackrel{\text{def}}{=} \square_{+\text{PL}} \square_{+\text{PL}}A$

The intuitive meanings of the previous connectives is:

- $\overline{\square}A$ means A is true for all points greater than the current one.
- $\overleftarrow{\square}A$ means A is true for all points smaller than the current one.
- $\square_C A$ means A is true for all points close to the current one.
- $\square_N A$ is read A is true for all points with respect to which the current one is negligible.

Definition 5 A *qualitative frame* for $\mathcal{L}(OM)^{+*}$ or, simply a *frame*, is a tuple $\Sigma = (\mathbb{S}, <, \mathcal{R}^+, \mathcal{R}^*)$, such that $(\mathbb{S}, <)$ a linearly ordered set divided into 11 qualitative classes as defined above, and $\mathcal{R} = \mathcal{R}^+ \cup \mathcal{R}^*$ an adequate set of relations for \mathbb{S} , as defined above.

Definition 6 Let $\Sigma = (\mathbb{S}, <, \mathcal{R}^+, \mathcal{R}^*)$ be a qualitative frame for $\mathcal{L}(OM)^{+*}$, a *qualitative model* based on Σ (or, simply a Σ -model) is an ordered pair $\mathcal{M} = (\Sigma, h)$ where $h : \mathcal{V} \rightarrow 2^{\mathbb{S}}$ is a function called *interpretation*. Any interpretation can be uniquely extended to the set of all formulae in $\mathcal{L}(OM)^{+*}$ (also denoted by h) by means of the usual conditions for the classical boolean connectives and for \top, \perp , and the following conditions:

$$h(\square_{+Q}A) = \{x \in \mathbb{S} \mid +Q(x) \subseteq h(A)\} \text{ for all } +Q \in \mathcal{R}^+.$$

$$h(\square_{*Q}A) = \{x \in \mathbb{S} \mid *Q(x) \subseteq h(A)\} \text{ for all } *Q \in \mathcal{R}^*.$$

$$h(q) = Q, q \in \{\text{nl}, \text{nm}, \text{ns}_2, -1, \text{ns}_1, 0, \text{ps}_1, 1, \text{ps}_2, \text{pm}, \text{pl}\}.$$

The concepts of truth and validity are defined in a standard way.

We conclude this section with two examples of application of our logic-based approach. Notice that unlike the previous two examples, we use now the language of the logic to express properties and concepts together with the results obtained by the tables.

Example 3 In a city like *Málaga* (Spain) where it does not rain very often, but there is a real danger of floods due to torrential rain, there is a dam very close to the city. If we represent the quantity of water in the reservoir by a qualitative class $P \in \{\text{PS}, \text{PM}, \text{PL}\}$, we can express with our language many interesting situations. For instance, assume $\text{pm} \leftrightarrow \text{warning}$, meaning that if the quantity of water is medium, then a warning or possible risk of overflow of the reservoir must show up, and may be the decision would be to open the floodgates before the rain comes; $\text{pl} \leftrightarrow \text{open}$, meaning that if the quantity of water is large, then it is necessary to open the floodgates: and $\neg(\text{pm} \vee \text{pl}) \rightarrow \text{ok}$, meaning that if the quantity of water is small, the situation is OK. Now, our system allows us to make many inferences. For instance, axiom **QC5**, and our previous assumptions, lead to

³For simplicity and by abuse of notation, we denote the formulas $-1, 0, 1$ as its corresponding qualitative class.

$ps \rightarrow \Box_{PM}(\text{warning} \vee \text{open})$, that is, if the quantity of water in the reservoir is small but a medium rain is expected, then either a warning must show up, or the floodgates may be opened.

Moreover, from axioms **QC4** and **QC6**, we deduce, $ps \rightarrow \Box_C \neg \text{open}$, and $\Box_N \text{open}$, respectively. The intuitive meaning of the first formula is that if the reservoir contains a small quantity of water, then floodgates have not to be opened whenever a small rain is expected. On the other hand, the second formula means that if the quantity of water in the reservoir is negligible with respect to the rain expected, then the flood gates must be open.

Obviously, our logic apparatus is interesting in many other scenarios; for instance, when considering the implementation of systems for energy efficiency. If we interpret PS and PM as the normal energy consumption, and PL as a waste of energy, formulas like $ps \rightarrow \Box_{PM} \text{warning}$, mean that if the consumption of energy is normal, any medium increase of this consumption, can be considered as a danger of waste of energy, and the systems for saving energy should start.

Example 4 The system $\mathcal{L}(OM)^{+*}$ allows us to enter the research topic of qualitative differential equations [12], albeit at a very preliminary level.

Let us consider now the differential equation

$$\frac{X'}{X} = a \quad (3)$$

being X a function $X: \mathbb{R}^+ \rightarrow \mathbb{R}^+$ and $a \in \mathbb{R}$. Our approach can be used to reason qualitatively about how the change in the values of the constant a may influence the solution of (3), $X(t) = Ke^{at}$ for $K \in \mathbb{R}^+$. For instance, we can use the formula

$$ns \rightarrow \Box_{PM}(ps \vee pm)$$

obtained from the mirror image of axiom **QC7** to state that if a is a negative small number and we add a positive medium number b to a , then the general solution X of the differential equation

$$\frac{X'}{X} = a + b$$

will be a strictly increasing function, because the $a + b$ is a positive small or medium number. On the other hand, the formula

$$nm \rightarrow \Box_N pl$$

deduced from definition of \Box_N and axioms **QC6** and **QC9** means that if the constant a in equation (3) is substituted by a constant d , such that a is negligible with respect to d , then the solution of the differential equation will be a strictly increasing function which increases very fast, due to the fact that the relative increasing rate is a large positive number. All these inferences can certainly be generalized to the case where $X = (X_1, \dots, X_n)$ with $X_i: \mathbb{R} \rightarrow \mathbb{R}$, ($i = 1, \dots, n$), a is a matrix of size n , and (3) is a system of linear differential equations.

4 Conclusions and future work

The logic $\mathcal{L}(OM)^{+*}$ for order of magnitude reasoning to deal with the qualitative operations of sum and product has been presented. In order to formalize these operations in terms of a logical system, some definitions and considerations have been necessary in order to express the basic properties needed. We showed also some examples about how to reason by using this logic.

As a future work, we are working on a sound and complete axiom system for this logic. Moreover, we are thinking on different notions of negligibility and closeness in the line of [1]. Last but not least, we will consider the proof of decidability of this logic and a theorem prover in the line of [13].

Acknowledgments

This work is partially supported by the Spanish research projects TIN2009-14562-C05-01, TIN2012-39353-C04-01 and Junta de Andalucía project P09-FQM-5233.

References

- [1] A. Ali, D. Dubois, and H. Prade. Qualitative reasoning based on fuzzy relative orders of magnitude. *IEEE transactions on Fuzzy Systems*, 11(1):9–23, 2003.
- [2] M. Bhatt, H. Guesgen, S. Wöflf, and S. Hazarika. Qualitative spatial and temporal reasoning: Emerging applications, trends, and directions. *Spatial Cognition & Computation*, 11(1):1–14, 2011.
- [3] D. G. Bobrow. *Qualitative reasoning about physical systems*. The MIT Press, Cambridge, MA, 1985.
- [4] B. Bredeweg and P. Struss. Current topics in qualitative reasoning. *AI Magazine*, 24(4):13, 2003.
- [5] A. Burrieza, E. Muñoz-Velasco, and M. Ojeda-Aciego. A logic for order of magnitude reasoning with negligibility, non-closeness and distance. *Lecture Notes in Artificial Intelligence*, 4788:210–219, 2007.
- [6] A. Burrieza, E. Muñoz-Velasco, and M. Ojeda-Aciego. Closeness and distance in order of magnitude qualitative reasoning via PDL. *Lecture Notes in Artificial Intelligence*, 5988:71–80, 2010.
- [7] A. Burrieza, E. Muñoz-Velasco, and M. Ojeda-Aciego. A PDL approach for qualitative velocity. *International Journal of Uncertainty, Fuzziness and Knowledge-Based Systems*, 19(01):11–26, 2011.
- [8] E. Davis. Order of magnitude reasoning in qualitative differential equations. *Readings in Qualitative Reasoning about Physical Systems*, Morgan Kaufmann, pages 422–434, 1990.
- [9] D. Dubois and H. Prade. Fuzzy arithmetic in qualitative reasoning. In *Modeling and Control of Systems*, pages 457–467. Springer, 1989.
- [10] B. Faltings and P. Struss. *Recent advances in qualitative physics*. MIT Press, 1992.
- [11] K. D. Forbus. Qualitative reasoning about physical processes. *IJCAI-7, Vancouver, BC*, 1981.

- [12] K. D. Forbus. Qualitative reasoning. In *CRC Handbook of Computer Science and Engineering*, pages 715–733. CRC Press, 1996.
- [13] J. Golińska-Pilarek, A. Mora, and E. Muñoz-Velasco. An ATP of a relational proof system for order of magnitude reasoning with negligibility, non-closeness and distance. *Lecture Notes in Artificial Intelligence*, 5351:128–139, 2008.
- [14] J. Golińska-Pilarek and E. Muñoz-Velasco. Reasoning with qualitative velocity: Towards a hybrid approach. *Lecture Notes in Computer Science*, 7208:635–646, 2012.
- [15] T. R. Hinrichs and K. D. Forbus. Learning qualitative models by demonstration. In *Twenty-Sixth AAAI Conference on Artificial Intelligence*, 2012.
- [16] K. Kansou, T. Nuttle, K. Farnsworth, and B. Bredeweg. How plants changed the world: Using qualitative reasoning to explain plant macroevolution’s effect on the long-term carbon cycle. *Ecological Informatics*, 2013. To appear.
- [17] M. Klenk, D. G. Bobrow, J. de Kleer, J. Hanley, and B. Janssen. Placing qualitative reasoning in the design process. In *Proc. 26th Int. Workshop on Qualitative Reasoning, Playa Vista, CA*, pages 16–18, 2012.
- [18] B. Kuipers. *Qualitative reasoning: modeling and simulation with incomplete knowledge*. the MIT press, 1994.
- [19] H. Liu. A fuzzy qualitative framework for connecting robot qualitative and quantitative representations. *IEEE Transactions on Fuzzy Systems*, 16(6):1522–1530, 2008.
- [20] H. Liu, D. J. Brown, and G. M. Coghill. Fuzzy qualitative robot kinematics. *IEEE Transactions on Fuzzy Systems*, 16(3):808–822, 2008.
- [21] M. L. Mavrovouniotis, G. Stephanopoulos, and G. Stephanopoulos. Formal modeling of approximate relations in biochemical systems. *Biotechnology and Bioengineering*, 34(2):196–206, 1989.
- [22] A. Missier, N. Piera, and L. Travé-Massuyès. Order of magnitude qualitative algebras: A survey. *Revue d’intelligence artificielle*, 3(4):95–109, 1989.
- [23] N. Piera, M. Sánchez, and L. Travé-Massuyès. Qualitative operators for order of magnitude calculers: Robustness and precision en proc. In *43th IMACS World Congress on Computation and Applied Mathematics, Dublin*, pages 1–6, 1991.
- [24] O. Raiman. Order of magnitude reasoning. *Artificial Intelligence*, 51:11–38, 1991.
- [25] L. Roselló, F. Prats, N. Agell, and M. Sánchez. Measuring consensus in group decisions by means of qualitative reasoning. *International Journal of Approximate Reasoning*, 51(4):441–452, 2010.
- [26] M. Sánchez, F. Prats, and N. Piera. Una formalización de relaciones de comparabilidad en modelos cualitativos. *Boletín de la AEPIA (Bulletin of the Spanish Association for AI)*, 6:15–22, 1996.
- [27] M. Sheremet, F. Wolter, and M. Zakharyashev. A modal logic framework for reasoning about comparative distances and topology. *Annals of Pure and Applied Logic*, 161(4):534–559, 2010.
- [28] L. Travé-Massuyès, L. Ironi, and P. Dague. Mathematical foundations of qualitative reasoning. *AI magazine*, 24(4):91, 2003.
- [29] L. Travé-Massuyès, F. Prats, M. Sánchez, and N. Agell. Relative and absolute order-of-magnitude models unified. *Annals of Mathematics and Artificial Intelligence*, 45(3-4):323–341, 2005.
- [30] S. Tsumoto. Qualitative simulation based on ranked hyperreals. In *IEEE Intl Conf on Granular Computing (GrC)*, pages 767–771, 2010.
- [31] D. S. Weld and J. d. Kleer. *Readings in qualitative reasoning about physical systems*. Morgan Kaufmann Publishers Inc., 1989.

Using Planning with Qualitative Simulation for Multistrategy Learning of Robotic Behaviours

Timothy Wiley and Claude Sammut
School of Computer Science & Engineering
The University of New South Wales
Sydney, Australia 2052
{timothyw, claude}@cse.unsw.edu.au

Ivan Bratko
Artificial Intelligence Laboratory
Faculty of Computer & Information Science
University of Ljubljana
SI-1000 Ljubljana, Slovenia
{bratko@fri.uni-lj.si}

Abstract

Learning robotic behaviours is a challenging task as the systems are continuous, noisy and non-deterministic. Most current methods for learning robotic behaviours are domain dependent. Thus, for each domain a new learner must be developed. In this paper, we propose a method for learning robotic behaviours in a domain independent manner, by building on previous work in Multistrategy Learning. Using a qualitative representation of the robotic system, we combine a planner with Qualitative Simulation to create a parameterised sequence of actions that solves a given task. This action sequence is then refined by a quantitative optimiser, producing a controller that successfully completes the task.

1 Introduction

To complete a task, an autonomous agent must plan and execute a sequence of actions. Planning in robotics is particularly challenging since domains may be very large, possibly infinite and they are usually continuous, noisy, and non-deterministic. Thus, learning robotic behaviours has typically used stochastic planning. Stochastic planners often represent the task as a Markov Decision Problem (MDP) [Bellman, 1957] for which some form of trial-and-error is used to learn the parameters of the MDP. Abbeel *et al.* [2010] and Stulp *et al.* [2010] show excellent performance with this approach in their respective domains of autonomous helicopter flight and humanoid walking. Techniques such as reward shaping [Ng *et al.*, 1999] are used to speed up learning the MDP, while many model-based [Hoey *et al.*, 1999] and Hierarchical [Powers and Balch, 2009] methods for learning the MDP provide performance boosts for planning. The layered architecture of Powers and Balch is similar in spirit to ours, but like the other methods it has a significant drawback. The learning system must be heavily engineered to a specific domain. If the domain changes, a new learner must be developed.

Our research focuses on modelling domain knowledge, which can then be used to constrain the search space of a stochastic planner. The method we present is motivated by how humans learn to perform complex tasks. Consider learning to drive a car that has a manual gear shift. A driving in-

structor does not say to a student “Here is the steering wheel, the gear lever, and the pedals. Play with them and figure out how to drive”. Instead the instructor gives the student a sequence of actions to perform, such as “To change gears, depress the clutch as the accelerator is released, followed by a gear change” and so on. However, this sequence is insufficient as the instructor cannot tell precise speed and timing with which to perform these actions. The student must learn these by trial-and-error.

Sammut and Yik [2010] proposed a multistrategy technique for learning robot behaviours that combines planning with trial-and-error learning. Their architecture is shown in Figure 1. The planner uses parameterised action models, where the parameters are acquired by trial-and-error. However, the parameter search space is limited by the constraints derived from the qualitative plan.

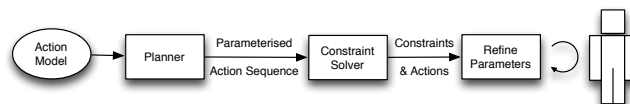

Figure 1: Multistrategy Learning Architecture

Sammut and Yik successfully applied their method to learning a bipedal gait. A humanoid robot was able to learn a stable walk in an average of 40 trials, despite the robot having 23 degrees of freedom. However, the planner was strongly tailored to the domain. We present a generalisation of this approach, modifying the architecture by replacing the action model by a qualitative model. We then build a planner that uses Qualitative Simulation (QSIM) [Kuipers, 1986] to reason about the effects of actions. The advantage of using qualitative models for planning is that the action model language does not need to be domain specific and the qualitative models can be learned [Bratko *et al.*, 1991], thus opening the possibility of automatically acquiring domain knowledge.

We present a system for planning actions for a robot using qualitative simulation. The formalisation allows easy integration into a multistrategy learning architecture. The examples presented in this paper model a modified iRobot Negotiator robot, shown in Figure 2a. The robot has a main body which is driven by a set of tracks, like a tank. A pair of sub-tracks, or flippers, are attached at the front of the robot and can be ro-

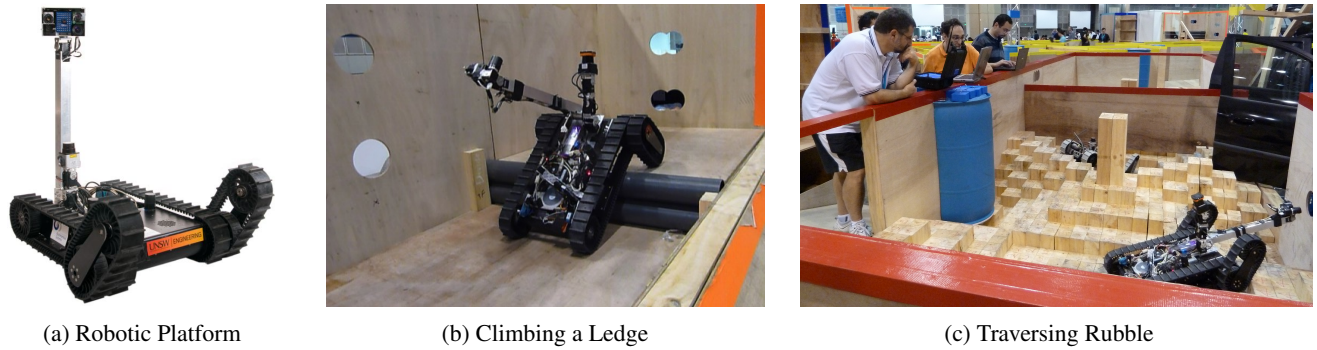

Figure 2: Negotiator robot and simulated disaster environments

tated to raise the body or give the robot a better angle of attack when approaching an obstacle. We use this robot for research in Urban Search and Rescue, specifically, for autonomous exploration and identification of human victims in dangerous environments, such as collapsed buildings. A challenge for this kind of robot is traversing uneven terrain, such as ledges (Figure 2b), staircases, and rubble (Figure 2c). In this paper, we apply our planning system to climbing onto a ledge. The difficulty here is deciding how to approach an object and how to move the flippers, which are often essential for climbing over obstacles. Planning these moves is greatly assisted by having a qualitative model of the robot.

Before describing the robot model and its use in planning, we discuss related work. Section 3 then gives details of the model implemented for the Negotiator robot. We describe the QSIM formalism for planning in Section 4 and how the actions are selected in Section 6. Section 7 describes future work and conclusions.

2 Related Work

The use of qualitative reasoning for planning actions is not new. Hogge [1987] and Forbus [1989] proposed planning systems that are similar to ours. They use qualitative process theory to search for a sequence of qualitative states that lead from an initial state to a goal state. We use an extended version of QSIM to generate parameterised qualitative plans. One of the goals of this representation is to use the constraints from the qualitative plan to reduce the search space of a trial-and-error learning system, whose task is to convert the qualitative plan into numerical motor commands for a robot.

DeJong [1994] and Drabble [1993] developed reactive monitoring systems. They use qualitative reasoning to predict the next state of a system and adjust the quantitative controls of the system accordingly. However, we require a planner that devises a plan before attempting to execute it. Troha and Bratko [2011] successfully performed planning using QSIM, although, their system is specialised for learning the effects of object pushing.

Mugan and Kuipers [2012] developed a domain independent system, using a different qualitative reasoning system to QSIM. They learn small quantitative controllers for properties of the form $X \rightarrow x$, which set variable X to the qualitative value x . The controllers are linked in a tree-like fash-

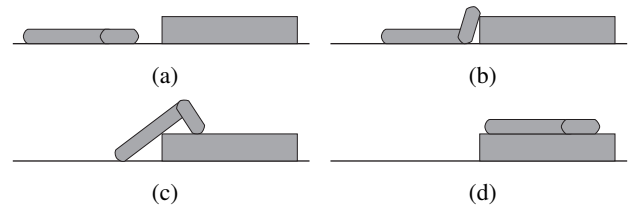

Figure 3: Sequence of actions for climbing the ledge

ion to allow actions to be completed. We represent the entire system using Qualitative Differential Equations (QDEs) with extensions that allow us to modularise the robot model so that different situations can be handled.

3 Example

To demonstrate the planner, we apply it to the Negotiator robot climbing a ledge. Figure 3 shows a sequence of states the robot might traverse to complete the task. There is insufficient space to give full details, so we show a subset that highlights various aspects of the method. Full details are given in Wiley [2013]. The robot drives until it is in front of the ledge. It raises its sub-tracks (flippers) so that it can climb the step, then resumes driving forward, pushing its body up the step. When the robot's centre of mass is past the edge of the step, the flippers are lowered and the robot drives the rest of the way into the ledge.

The qualitative model uses QSIM's notation. The qualitative variables (QVars) and landmarks of the system are shown in Figure 4 and listed in Table 1. They represent the positions and angles of the robot's body and the angle of the flippers.

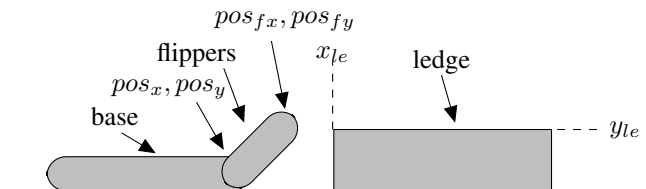

Figure 4: Negotiator Qualitative Variables

QVar	Landmarks	Description
θ_b	$[-\pi, 0, \pi]$	Base angle
θ_f	$[-\pi, 0, \pi]$	Flipper angle (Control Variable)
θ_{fb}	$[-\pi, -\frac{\pi}{2}, 0, \frac{\pi}{2}, \pi]$	Sum of θ_f and θ_b
pos_x	$[x_{min}, x_{le}, x_{max}]$	Robot x -position
pos_y	$[y_{min}, y_{le}, y_{max}]$	Robot y -position
pos_{fx}	$[x_{min}, x_{le}, x_{max}]$	Flipper x -position
pos_{fy}	$[y_{min}, y_{le}, y_{max}]$	Flipper y -position
com	$[x_{min}, x_{max}]$	Centre of Mass
v	$[v_{min}, 0, v_{max}]$	Velocity of the robot (Control Variable, Discrete)

Table 1: Negotiator Qualitative Variables

In addition to these state variables, we introduce two *control variables*. We regard an action as setting the value of a control variable, such as setting the speed of the robot’s tracks and the angle of the flippers. Note that on the Negotiator, the main tracks and sub-tracks move at the same speed.

3.1 Constraints

In QSIM, constraints describe how qualitative variables are related. For example, the angle of the robot’s body with respect to the ground depends on the angle of the flippers. In a system such as this, several sets of constraints may be needed, depending on the situation. While the flippers are raised and the robot is on flat ground, the flipper angle has no effect on the angle of the base. However, if the flippers are lowered, the body is raised. Once the robot has pushed itself onto the step, these operators may no longer be valid. Thus, we group constraints into different *operating regions*. Now, the QSIM model consists of a set of rules of the form:

$$Name : Precondition \rightarrow Constraints \quad (1)$$

where *Precondition* specifies in which operating region the set of associated *Constraints* are applicable. That is, the QSIM algorithm is modified to enforce only those constraints whose preconditions are satisfied. Table 2 shows the constraints for three regions where the robot is on flat ground.

Name	Region	Constraints
flat_1	$-\pi \leq \theta_{fb} \leq 0$	const(θ_b , 0)
flat_2	$0 \leq \theta_{fb} \leq \frac{\pi}{2}$	M-(θ_b , θ_{fb}), corr(0, 0) M+(θ_f , θ_{fb}), corr(0, 0)
flat_3	$\frac{\pi}{2} \leq \theta_{fb} \leq \pi$	M+(θ_b , θ_{fb}), corr(0, π) M+(θ_f , θ_{fb}), corr(π , π)

Table 2: Constraints for operating on flat ground

Table 3 shows the constraints that govern the behaviour of the robot as it transitions over the leading edge of the ledge, until the robot returns to the flat environment on top of the

ledge. These constraints also demonstrate how some transitions may lead to impossible states, indicated by \perp , the unsatisfiable constraint. Any transitions into these regions are immediately discarded. In our example impossible states include any where the bounds of the robot, such as the position of the flippers, overlaps with the boundaries of the ledge. That is, any values of the variables that places the robot inside the ledge.

The behaviour of the robot in the step environment is determined by three variables, $max_{p_{touch}}$, $\theta_{critical}$ and com . $max_{p_{touch}}$ is the limit for the x -position of the robot before the robot impacts the ledge. This value varies according to the angle of the flipper and the angle of the base. $\theta_{critical}$ is the upper limit of the angle the flipper before the robot is no longer physically able to climb the ledge. Finally the centre of mass of the robot, com , defines the operating region where the robot has traversed the step and returns to the flat ground environment.

The constraints shown in Table 4 include rules for driving and properties of the physical robot, such as the position of the flippers. These constraints show the advantage of the piecewise specification of constraints. These constraints are applicable across both the flat and step environment, but only need to be specified by one collection of operating regions.

It should be noted that operating regions, as define here, may overlap. For example, the operating regions flat_1 and flat_2 from Table 2, overlap in qualitative states where $\theta_{fb} = 0/\perp$. In these states the constraints from both regions are applied. Such overlapping applications do not cause conflicts between constraints as overlaps occur where operating regions that reference the same set of values transition between the constrains that should be applied. This can be seen in the transition from the angle of the base remaining constant, to the angle being dependent on the angle of the flipper.

3.2 The Plan

The planner is implemented in Prolog and is an extension of Bratko’s QSIM simulator [Bratko, 2011]. The program generates a sequence of qualitative states that leads to the goal state. In our example, the sequence terminates with completing climbing the ledge and is summarised in Table 5. Again, a subset of states is shown. From t_0 to t_2 , the robot approaches the ledge (Figure 3a). In the interval $t_6 .. t_7$ the robot is driving over the ledge (Figure 3b). In $t_{11} .. t_{12}$ the robot has lowered the flipper to continue driving (Figure 3c). Finally at t_{14} the task is complete (Figure 3d).

Table 6 lists the sequence of actions that corresponds to the transitions between the states in Table 5. Note that, actions can occur in parallel, as in a_2 , where the velocity is set to 0 while the flipper angle is decreased. Some actions may be empty, as from a_5 to a_8 . This is because the robot continues to drive forward, moving through many qualitative states as a result of variables passing the x_{le} and y_{le} landmarks.

The plan in Table 6 is only a general guide to how to climb the ledge, much like the driving instructor’s explanation of how to change gears. In particular, the actions only specify intervals for control variables such as the flipper angle. The precise values must be found by trial-and-error learning. However, the plan does tell the learner to restrict its trials to

Name	Region	Constraints
inside_step_1	$pos_x > x_{le}, pos_y < y_{le}$	\perp
inside_step_2	$pos_{fx} > x_{le}, pos_{fy} < y_{le}$	\perp
inside_step_3	$pos_{bx} > x_{le}, pos_{by} < y_{le}$	\perp
stepf_posx_1	$pos_x \leq max_{pxtouch}, \theta_b = 0$	$M-(\theta_f, max_{pxtouch}),$ $corr(0, x_{le} - flen), corr(-\frac{\pi}{2}, x_{le})$
stepf_posx_2	$pos_x = max_{pxtouch}, \theta_{fb} < 0$	$const(pos_x, max_{pxtouch})$ $const(max_{pxtouch}, x_{le} - flen .. x_{le})$
stepf_invalid_1	$\theta_b = 0, pos_x > max_{pxtouch}$	\perp
stepf_invalid_2	$\theta_{fb} < 0, pos_x > max_{pxtouch}$	\perp
stepf_invalid_3	$\theta_f < \theta_{critical}, pos_x > max_{pxtouch}$	\perp
stepf_fb_1	$pos_x < max_{pxtouch}$	$const(\theta_b, 0)$
stepb_invalid_1	$\theta_{fb} < 0$	\perp
stepb_invalid_2	$com < x_{le}, pos_x > max_{pxtouch}$	\perp
stepb_posx_1	$0 \leq \theta_{fb} \leq \frac{\pi}{2}$	$M+(\theta_{fb}, max_{posxtouch})$ $corr(0, x_{le}), corr(\frac{\pi}{2}, x_{le} .. x_{max})$
stepb_posx_2	$\frac{\pi}{2} \leq \theta_{fb} \leq \pi$	$M-(\theta_{fb}, max_{pxtouch})$ $corr(\frac{\pi}{2}, x_{le} .. x_{max}), corr(\pi, x_{le})$
stepb_posx_3	$com \geq x_{le}$	$M-(pos_x, \theta_b)$
stepb_fb_1	$0 \leq \theta_{fb} \leq \frac{\pi}{2}$	$M-(\theta_b, \theta_{fb}), M+(\theta_f, \theta_{fb})$
stepb_fb_2	$\frac{\pi}{2} \leq \theta_{fb} \leq \pi$	$M+(\theta_b, \theta_{fb}), M+(\theta_f, \theta_{fb})$

Table 3: Example of step region constraints

a much narrower range of parameter values than it would if some form of Reinforcement Learning were applied naively. We intend to follow the same method as Sammut and Yik [2010], using the constraints from the QSIM plan to bound the search space for a Markov chain Monte Carlo (MCMC) sampling of the parameter space [Andrieu *et al.*, 2003]. This performs what is, essentially, a hill-climbing search of the parameter space, selecting a point in the multi-dimensional space of parameter values, testing those values, then selecting a new point based on the results of the trial. In this case, the trial is the robot’s attempt to climb the ledge. We refer the reader to Sammut and Yik [2010] for details of this method. In the remainder of this paper, we focus on how the planning works. In particular, we address the problems that arise when trying to run the plan on a real robot.

4 Qualitative Planning

Given a qualitative state, q_i , QSIM determines all successor states $\{q_{i+1}\}$, using a transition table, T , which specifies all possible values that variables may take in q_{i+1} . The model places constraints on these values by specifying relationships between variables. The model is said to validate the state, that is, $M(q_{i+1})$ holds if state, q_{i+1} , is valid under model, M . As described in Section 3.1, the model consists of a set of constraints that may be qualified by the operating region in which they are applicable.

Thus, the QSIM algorithm determines successor states as follows:

1. For each qualitative variable in q_i , use T to determine all values the variable may take in q_{i+1} .
2. Collect the cross-product of qualitative variable values into a set of potential successor states Q_{i+1} .

3. Remove from Q_{i+1} any state q_{i+1} where $M(q_{i+1})$ does not hold. This step differs from standard QSIM in that we first check the preconditions of each set of constraints, and only apply those whose preconditions are satisfied. That is, we only enforce the constraints that are valid in the current operating region.

QSIM assumes that variables in qualitative states are dependent, or state variables. That is, the variables in the state may not freely change value. Instead they are determined or constrained by exterior actions. For planning, we introduced *control variables*, which, when set, effect changes in the state of the system. Thus, the qualitative state contains two types of variables: control variables and state variables.

The performance of an action is represented by a change in value of one or more control variables (CQVar). Thus, an action, a , has the form:

$$\{CQVar = \text{Dom/Mag}, \dots\} \quad (2)$$

where each CQVar appears at most once within the set. We modify the transition table T of QSIM, to the transition table for planning, T_p , such that T_p contains all the smooth transitions of T , applicable to state variables, plus additional, non-smooth transitions applicable to control variables.

Planning then uses the following algorithm. In state q_i :

1. choose an action a_i ,
2. use QSIM to calculate $\{q_{i+1}\}$ given a_i and T_p ,
3. filter q_{i+1} through the complete qualitative model.

It is possible that there are no valid successor states under the model, M .

QSIM assumes time can be represented by a continuous sequence of non-zero time intervals, $t_i .. t_{i+1}$. Intervals are separated by time points, t_i . While time points are ordered,

Name	Region	Constraints
drive		$\text{deriv}(pos_x, v)$
sum_fb		$\text{sum}(\theta_f, \theta_b, \theta_{fb})$
posfx_1	$-\pi \leq \theta_{fb} \leq 0$	$M+(\theta_{fb}, pos_{fx}), \text{corr}(-\pi, pos_x - flen), \text{corr}(-\frac{\pi}{2}, pos_x), \text{corr}(0, pos_x + flen), \dots$
posfx_2	$0 \leq \theta_{fb} \leq \pi$	$M-(\theta_{fb}, pos_{fx}), \text{corr}(0, pos_x + flen), \text{corr}(\frac{\pi}{2}, pos_x), \text{corr}(\pi, pos_x - flen), \dots$
posfy_1	$-\pi \leq \theta_{fb} \leq -\frac{\pi}{2} \vee \frac{\pi}{2} \leq \theta_{fb} \leq \pi$	$M+(\theta_{fb}, pos_{fy}), \text{corr}(-\pi, pos_y), \text{corr}(-\frac{\pi}{2}, pos_x + flen), \text{corr}(\frac{\pi}{2}, pos_y - flen), \text{corr}(\pi, pos_y)$
posfy_2	$-\frac{\pi}{2} \leq \theta_{fb} \leq \frac{\pi}{2}$	$M-(\theta_{fb}, pos_{fy}), \text{corr}(-\frac{\pi}{2}, pos_x + flen), \text{corr}(0, pos_y), \text{corr}(\frac{\pi}{2}, pos_y - flen)$
posbx_1	$-\pi \leq \theta_{fb} \leq 0$	$M-(\theta_{fb}, pos_{bx}), \text{corr}(-\pi, pos_x + baselength), \text{corr}(-\frac{\pi}{2}, pos_x), \text{corr}(0, pos_x - baselength)$
posbx_2	$0 \leq \theta_{fb} \leq \pi$	$M+(\theta_{fb}, pos_{bx}), \text{corr}(0, pos_x - baselength), \text{corr}(\frac{\pi}{2}, pos_x), \text{corr}(\pi, pos_x + baselength)$
posby_1	$-\pi \leq \theta_{fb} \leq -\frac{\pi}{2} \vee \frac{\pi}{2} \leq \theta_{fb} \leq \pi$	$M-(\theta_{fb}, pos_{by}), \text{corr}(-\frac{\pi}{2}, pos_x - baselength), \text{corr}(-\pi, pos_y), \text{corr}(\frac{\pi}{2}, pos_y + baselength), \text{corr}(\pi, pos_y)$
posby_2	$-\frac{\pi}{2} \leq \theta_{fb} \leq \frac{\pi}{2}$	$M+(\theta_{fb}, pos_{by}), \text{corr}(-\frac{\pi}{2}, pos_x - baselength), \text{corr}(0, pos_y), \text{corr}(\frac{\pi}{2}, pos_y + baselength)$
com_1	$-\pi \leq \theta_b \leq 0$	$M-(com, \theta_b), \text{corr}(pos_x, -\frac{\pi}{2}), \text{corr}(pos_x - com_{disp}, 0)$
com_2	$0 \leq \theta_b \leq \pi$	$M+(com, \theta_b), \text{corr}(pos_x - com_{disp}, 0), \text{corr}(pos_x, \frac{\pi}{2})$

Table 4: Global constraints. The value $flen$ is the length flipper

QVar	$t_0..t_1$	$t_1..t_2$	$t_6..t_7$	$t_{11}..t_{12}$	$t_{14}..t_{15}$
θ_f	0/std	0/std	$-\pi..0/\text{std}$	$0..\pi/\text{std}$	0/std
θ_b	0/std	0/std	$-\pi..0/\text{dec}$	$-\pi..0/\text{inc}$	0/std
pos_x	$x_{min}..x_{le}/\text{std}$	$x_{min}..x_{le}/\text{inc}$	$x_{min}..x_{le}/\text{inc}$	$x_{le}..x_{max}/\text{inc}$	$x_{le}..x_{max}/\text{std}$
pos_y	0/std	0/std	0/std	$y_{le}..y_{max}/\text{std}$	y_{le}/std
pos_{fx}	$x_{min}..x_{le}/\text{std}$	$x_{min}..x_{le}/\text{inc}$	$x_{le}..x_{max}/\text{inc}$	$x_{le}..x_{max}/\text{inc}$	$x_{le}..x_{max}/\text{std}$
pos_{fy}	0/std	0/std	$y_{le}..y_{max}/\text{inc}$	y_{le}/std	y_{le}/std
v	0/std	v_{max}/std	v_{max}/std	v_{max}/std	0/std

Table 5: Sequence of states to climb the ledge. Some time intervals have been left out

their absolute values are unknown. Time points may occur microseconds or minutes apart. Each time point or interval is mapped to a qualitative state (Figure 5). The system transitions between time points and intervals in a regular fashion. Thus, each action is additionally parameterised by a time point or interval (Equation 3).

$$\begin{aligned}
 a_i &:= \{(CQVar = \text{Dom}/\text{Mag}, t_i), \dots\} \\
 a_{i,i+1} &:= \{(CQVar = \text{Dom}/\text{Mag}, t_i..t_{i+1}), \dots\}
 \end{aligned} \quad (3)$$

5 Planning for Execution on a Robot

Given a starting state for the robot, planning finds a sequence of intermediate qualitative states, and corresponding actions, that will reach a goal state. However, the plan is not operational in the sense that it does not contain the numerical parameters required for motor commands. As described previously, these are found by using the qualitative constraints from the plan to reduce the search space for a numerical optimisation technique, which generates experiments to be performed by the robot, finding the parameter values. Because the plan will be executed on a real robot, some refining of the plan is required.

A time point is infinitesimally small, however, any practically meaningful action performed by a robot requires non-zero time duration. Therefore, an action only lasting for a time point has no effect, so we simplify the plan by merging the time points with the succeeding time interval. Thus, no action is generated for transition points that have zero duration. Every action is parameterised by a time interval $t_i..t_{i+1}$. We can say that each action is invoked at the time point at which the interval begins.

A detailed example of a plan was given in Section 3.2. The plan for the Negotiator to climb a ledge, starts by driving forward, stopping, then raising the flippers. The plan does not specify how long to drive forward. That is the value of t_2 , at which driving should stop. The plan also does not specify the angle at which the flipper should be positioned. The plan only states that the angle should increase within the range $-\pi..0$ until the desired angle is reached. These constraints are passed to the trial-and-error learning phase, which determines:

- the optimal values for time points t_i ,
- the optimal numerical values for control variables and

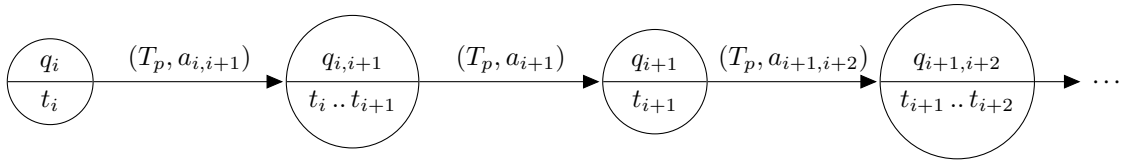

Figure 5: Time points and regions mapped to qualitative state during qualitative simulation

a_0	t_0	$v = 0/std$
a_1	t_1	$v = v_{max}/std$
a_2	t_2	$v = 0/std, \theta_f = -\pi .. 0/inc$
a_3	t_3	
a_4	t_4	$v = v_{max}/std, \theta_f = -\pi .. 0/std$
a_5	t_5	
\vdots	\vdots	
a_8	t_8	
a_9	t_9	$v = 0/std, \theta_f = -\pi .. 0/inc$
a_{10}	t_{10}	$\theta_f = 0 .. \pi/inc$
a_{11}	t_{11}	$v = v_{max}/std, \theta_f = 0 .. \pi/std$
a_{12}	t_{12}	
a_{13}	t_{13}	$v = 0/std, \theta_f = 0 .. \pi/dec$
a_{14}	t_{14}	$\theta_f = 0/std$

Table 6: Plan for climbing the ledge

- the optimal rates of change for control variables.

The planner allows for parallel actions to be specified. In the ledge climbing example of Table 6, at t_2 , two actions occur: velocity is set to zero, and the flipper angle decreases.

6 Benefits of using Operating Regions

As mentioned previously, the model for the entire system may be divided into different operating regions, each of which has its own set of constraints. The model, M_i , for a state, q_i , is the conjunction of all the constraints from every operating region whose pre-conditions are true in that state.

Our method of stating a qualitative model as a set of operating regions has several benefits. Firstly, it allows the complete model to be specified in a piecewise manner. This is useful because in a robot, different aspects of the system may be largely unrelated to each another. For example, on the Negotiator, the constraints for driving and controlling the flippers are unrelated. They use different variables that transition through landmarks at different points in time. There are several advantages of separating these constraints into different operating regions.

- Aspects of the robot can be added or removed easily. For example, the Negotiator has an arm with a sensor head, yet we do not provide any of the constraints for using the arm. If needed, these can be added without having to change the existing operators.
- Each aspect of the system can be learnt separately for learning the constraints for an operating region. Furthermore, if the system is changed, such as adding or re-

moving the Negotiator’s arm, it is not necessary to completely re-learn the operators.

- A human observer can more easily understand how each aspect of the robot operates.

As shown in our example (Section 3.1), different operating regions have different sub-models, i.e. constraints. Our formulation allows each operating region to be independently specified, using the same syntax. Furthermore, by changing only a few common pre-conditions, models for different operating regions can be linked together as required. Thus, the constraints can be adapted to different region configurations, without having to learn or provide new constraints.

7 Conclusion and Future Work

The main contributions of this work are in extending QSIM to easily incorporate many, possibly overlapping, operating regions required in complex modelling tasks for robotics. We have also adapted QSIM to generate a plan that consists of a sequence of qualitative actions that are specified by settings of control variables. The original motivation for this work was to use the constraints associated with each qualitative action to reduce the search space for a learning system that turns qualitative actions into quantitative commands that can be sent to actuators. Integration of the planner and learner remains to be completed. We will initially target climbing a ledge, and then expand the range of tasks to include climbing a stair case and traversing uneven terrain.

Forbus [1989] dismissed approaches like the one we have presented due to the large number of potential states to search through. However, Berleant and Kuipers [1997] described a method for propagating quantitative constraints through qualitative models. Such an idea fits nicely into our approach. We intend to incorporate the work of Berleant and Kuipers into the optimiser, greatly reducing the search space. This may also require changing the architecture to loop between the planner and optimiser.

We also leave for future work considerations of multiple plans. At this stage, we are only interested in finding a plan, if one exists.

References

- P. Abbeel, A. Coates, and A.Y. Ng. Autonomous Helicopter Aerobatics through Apprenticeship Learning. *The International Journal of Robotics Research*, 29(13):1608–1639, November 2010.
- Christophe Andrieu, Nando De Freitas, Arnaud Doucet, and Michael I. Jordan. An introduction to MCMC for machine learning. *Machine Learning*, 50(1-2):5–43, 2003.

- R. Bellman. A Markovian Decision Process. *Journal of Mathematics and Mechanics*, 6(4):679–684, 1957.
- D. Berleant and B.J. Kuipers. Qualitative and quantitative simulation: bridging the gap. *Artificial Intelligence*, 95(2):215–255, September 1997.
- Ivan Bratko, Stephen Muggleton, and Alen Varsek. Learning qualitative models of dynamic systems. In *In Proceedings of the Eighth International Workshop on Machine Learning*, pages 385–388. Academic Press, 1991.
- I. Bratko. *Prolog Programming for Artificial Intelligence*. Pearson, 4th edition, 2011.
- G.F. DeJong. Learning to Plan in Continuous Domains. *Artificial Intelligence*, 65(1):71–141, 1994.
- B. Drabble. EXCALIBUR: A Program for Planning and Reasoning with Process. *Artificial Intelligence*, 62(1):1–40, 1993.
- K.D. Forbus. Introducing Actions into Qualitative Simulation. *Artificial Intelligence (IJCAI), 11th International Joint Conference on*, pages 1273–1278, 1989.
- J. Hoey, R. St-Aubin, A. Hu, and C. Boutilier. SPUDD: Stochastic planning using decision diagrams. In *15th conference on Uncertainty in Artificial Intelligence (UAI)*, pages 279–288, 1999.
- J.C. Hogge. Compiling Plan Operators from Domains Expressed in Qualitative process Theory. In *Artificial Intelligence (AAAI), 6th National Conference on*, pages 229–233, 1987.
- B.J. Kuipers. Qualitative Simulation. *Artificial Intelligence*, 29(3):289–338, 1986.
- J. Mugan and B.J. Kuipers. Autonomous Learning of High-Level States and Actions in Continuous Environments. *Autonomous Mental Development, IEEE Transactions on*, 4(1):70–86, 2012.
- Andrew Y. Ng, Daishi Harada, and Stuart Russell. Policy invariance under reward transformations: Theory and application to reward shaping. In *Proceedings of the Sixteenth International Conference on Machine Learning*, pages 278–287. Morgan Kaufmann, 1999.
- M. Powers and T. Balch. A Learning Approach to Integration of Layers of a Hybrid Control Architecture. In *IEEE/RSJ International Conference on Intelligent Robots and Systems (IROS)*, pages 893–898, 2009.
- C. Sammut and T-F. Yik. Multistrategy Learning for Robot Behaviours. In J. Koronacki, Z. Ras, S. Wierzbicki, and J. Kacprzyk, editors, *Advances in Machine Learning I*, pages 457–476. Springer Berlin / Heidelberg, 2010.
- F. Stulp, J. Buchli, E.A. Theodorou, and S. Schaal. Reinforcement learning of full-body humanoid motor skills. In *IEEE-RAS International Conference on Humanoid Robots*, pages 405–410, 2010.
- M. Troha and I. Bratko. Qualitative learning of object pushing by a robot. *Qualitative Reasoning (QR), 25th International Workshop on*, pages 175–180, 2011.
- T. Wiley. Planning with qualitative constraints. Technical report, School of Computer Science and Engineering, The University of New South Wales, 2013.

Perceptual Narratives of Space and Motion for Activity Interpretation

Jakob Suchan and Mehul Bhatt
Cognitive Systems
University of Bremen, Germany

Paulo E. Santos
Centro Universitario da FEI,
S. Paulo, Brazil

Abstract

We propose a commonsense theory of *space* and *motion* for the high-level semantic interpretation of dynamic scenes. The theory provides primitives for commonsense representation and reasoning with *qualitative spatial relations*, *depth profiles*, and *spatio-temporal change*; these may be combined with a learning method (e.g., using hidden markov models) for modelling and hypothesising event and object relations. The proposed framework has been implemented as a general activity abstraction and reasoning engine, which we demonstrate by generating declaratively grounded visuo-spatial narratives of perceptual input from vision and depth sensors for a benchmark scenario.

Our long-term goal is to provide general tools (integrating different aspects of space, action, and change) necessary for tasks such as real-time human activity interpretation and dynamic sensor control within the purview of cognitive vision, interaction, and control.

Introduction

Systems that monitor and interact with an environment populated by humans and other artefacts require a formal means for representing and reasoning about spatio-temporal, event and action based phenomena that are grounded to real public and private scenarios (e.g., logistical processes, activities of everyday living) of the environment being modelled. A fundamental requirement within such application domains is the need to explicitly represent and reason about dynamic spatial configurations or scenes and, for real world problems, integrated reasoning about space, actions, and change [Bhatt, 2012]. With these modelling primitives, the ability to perform *predictive* and *explanatory* analyses on the basis of sensory data is crucial for creating a useful intelligent function within such environments.

Smart Meeting Cinematography. As a context for interpreting human activities, and to illustrate the concepts of this paper, we focus on professional tasks such as group meetings, discussions, and seminars. The scenario is a part of a bigger project described in the ROTUNDE initiative [Bhatt *et al.*, 2013a]. The particular setup used in this paper consists of the

PTZ cameras, depth sensors (Kinect), and a low-level vision module for people tracking (whole body, hand gesture, movement) customised on the basis of open-source algorithms and software.

Perceptual Narratives [Bhatt *et al.*, 2013b] are declarative models of visual, auditory, haptic and other observations in the real world that are obtained via artificial sensors and / or human input. As an example, consider the *smart meeting cinematography* domain, where *perceptual narratives* as in Fig. 1 are generated based on perceived spatial change interpreted as interactions of humans in the environment. Such narratives explaining the ongoing activities are needed to anticipate changes in the environment, as well as to appropriately influence the real-time control of the camera system.

Commonsense, Space, Change. Qualitative Spatial & Temporal Representation and Reasoning (QSTR) provide a commonsensical interface to abstract and reason about quantitative spatial information [Cohn and Renz, 2007]. *Qualitative spatial / temporal calculi* are relational-algebraic systems pertaining to one or more aspects of space such as *topology*, *orientation*, *direction*, *size* [Ligozat, 2013]. The integration of qualitative spatial representation and reasoning techniques within general commonsense reasoning frameworks in AI is an essential next-step for their applicability toward tasks such as spatial planning, spatio-temporal diagnosis and abnormality detection, event recognition and behaviour interpretation [Bhatt *et al.*, 2011a]. CLP(QS) [Bhatt *et al.*, 2011b] provides a framework for declarative spatial reasoning.

We suggest that the **cognitive interpretation** of activities from video, depth (e.g., time-of-flight devices such as Kinect), and other forms of sensory input requires the representational and inferential mediation of qualitative abstractions of *space*, *action*, and *change* [Bhatt, 2012]. Generation of perceptual narratives, and their access via the declarative interface of logic programming facilitates the integration of the overall framework in bigger projects concerned with cognitive vision, robotics, hybrid-intelligent systems etc. The particular focus and contributions of this paper are:

1. *Depth, space, motion*: declaratively reasoning about depth, qualitative spatial relations (e.g., topology, orientation), and motion in the context of everyday activities involving humans and artefacts
1. *Hybridisation*: integrating the qualitative theory with a HMM based learning method for hypothesising object

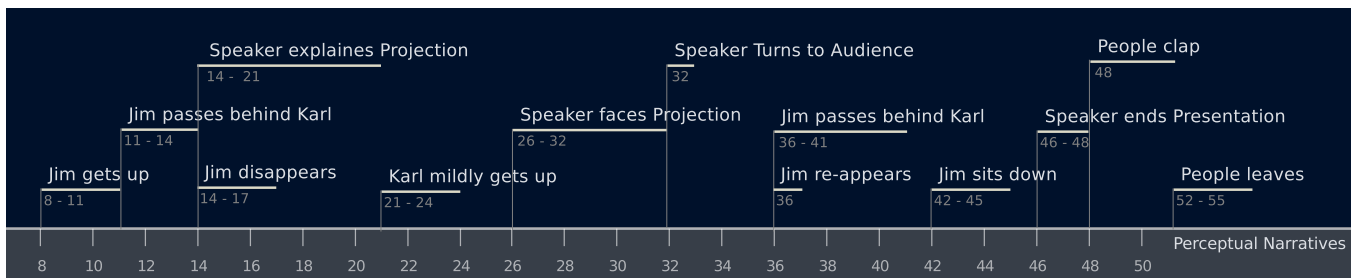

Figure 1: Cognitive Interpretation by Perceptual Narrativisation

relations

2. *Semantic characterisation*: as a result of (1) and (2), generation of declarative narratives of perceptual RGB-D data that is obtained directly from people/object tracking algorithms

Related Work

The core emphasis in activity and behaviour recognition has been on supervised learning algorithms requiring preprocessed (e.g., annotated) datasets from sensory streams. Unsupervised methods have received recent attention, with hybrid models integrating machine learning techniques with high-level structured representation and reasoning gaining recent momentum. The literature review below concentrates on proposals concerned with the main aspects of the investigation reported in the present paper, namely, the high-level interpretation of events from the standpoint of Qualitative Spatial & Temporal Representation and Reasoning (QSTR) using a Hidden Markov Modelling methodology for hypothesis generation. General reviews of work on activity and behaviour recognition can be found in [Lavee *et al.*, 2009; Gonzalez *et al.*, 2012; Poppe, 2010].

Scene Interpretation

Research on scene interpretation has been largely based on probabilistic methods, motivated by the need to deal with sensor noise and image uncertainty [Lavee *et al.*, 2009], leaving aside the representation of general facts about the domain and the interplay between this representation and the actual interpretation of the scenes. Logic-based image interpretation, on the other hand, tackles the problem from the viewpoint of effective representation of general facts about the domain, as well as the generalisation of these facts to problems with infinite variables. Close to the topic of this paper, [dos Santos *et al.*, 2009] presents a formalism for interpreting events such as *approaching*, *receding*, or *coalescing* from pairs of subsequent images obtained by a mobile robot’s stereopair. [Ferryhough *et al.*, 2000] proposed a technique for generating event models automatically based on qualitative reasoning and a statistical analysis of video input. This line of work has been further developed and has led to a range of related techniques broadly within the umbrella of the field of cognitive vision [Dubba *et al.*, 2010; Sridhar *et al.*, 2010; Dee *et al.*, 2012]. [Dee *et al.*, 2012] proposes a method based on unsupervised clustering for building semantic scene models from video data using observed motion. [Dubba *et al.*,

2010] presents a supervised learning framework to learn event models from large video datasets using inductive logic programming. [Tran and Davis, 2008] and [Morariu and Davis, 2011] present analogous results on the use of spatio-temporal relations within a first-order probabilistic language for the analysis of video sequences obtained in a parking lot.

Activity Recognition and Learning

The use of quantitative machine learning techniques for sensor data analysis and mining, e.g., to look for patterns in motion-data, and for activity and behaviour recognition has found wide acceptability [Schmitz *et al.*, 2012; Duong *et al.*, 2009; Liao *et al.*, 2005; Youngblood and Cook, 2007; Philipose *et al.*, 2004; Velastin *et al.*, 2005]. [Duong *et al.*, 2009] take into account the durative and hierarchical nature of human activities, that work applies the Coxian hidden semi-Markov model (CxHSMM) to the problem of learning and recognising activities of daily living with complex temporal dependencies. Similar in application and methods is the work described in [Liao *et al.*, 2005], which extends Relational Markov Models towards a general framework for location-based activity recognition. With a distinct focus, [Velastin *et al.*, 2005] takes into account public transport systems and develop an architecture that considers the distributed nature of the detection processes and the need to allow for different types of devices and actuators. [Philipose *et al.*, 2004] aim to infer activities from the interaction of individuals with objects, whereas works such as [Menon *et al.*, 2008] apply commonsense reasoning to integrate recognition and reasoning within a smart environment.

A Theory of Depth, Space, and Motion

The elementary entities of proposed theory are bounding boxes with an associated depth parameter. A bounding box is characterised as: $\langle (x, y, z), W, H \rangle$, where (x, y, z) is the 3D position of the bounding box’s centroid, W its width and H its height. We represent the apparent *depth*, *size*, *distance*, *displacement*, and *orientation* of pairs of bounding boxes, as relations defined in terms of the following functions on bounding boxes attributes:

depth: $\text{bounding box} \times \text{time point} \rightarrow \text{depth}$, gives a bounding box depth at a time instant;

size: $\text{bounding box} \times \text{time point} \rightarrow \text{size}$, maps a bounding box and a time point to the bounding box’s area;

dist: $\text{bounding box} \times \text{bounding box} \times \text{time point} \rightarrow \text{dist}$,

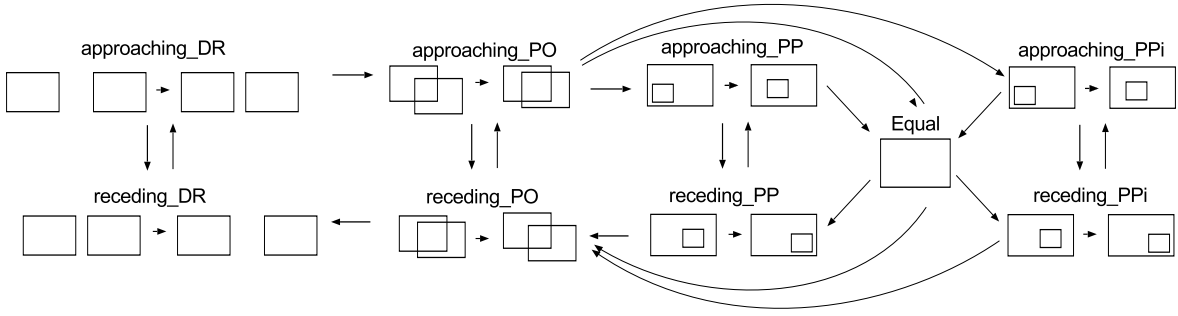

Figure 2: Conceptual neighbourhood diagram of dynamic distance relations

maps two bounding boxes and a time point to the angular distance separating the bounding boxes in that instant.

in_sight: $\text{bounding box} \times \text{time point} \rightarrow \text{in_sight}$, maps a bounding box and a time point to the visibility of the bounding box.

RCC5 Mereological Relations

The mereological system RCC5 which is a subset of the region connection calculus introduced in [Randell *et al.*, 1992] contains the relations DC (discrete), PP (proper part), PPI (inverse of proper part), PO (partially overlapping), and EQ (Equal) [Cohn *et al.*, 1997].¹ The topological relations are defined on the two dimensional image plane. Thus they do not represent the connection of two physical objects but rather the connection of the projection of two physical objects, which is in fact the visibility of the objects. Due to this fact the topological relations combined with the depth of the objects can be used to model the fact that that one object occludes the other.

Relative orientation

We introduce relative orientation, as defined in [Randell *et al.*, 2001], in terms of the relations *left* and *right* on bounding boxes. These relations will be used to represent directions of movement and relative position.

Depth Relations on Bounding Boxes

Depth of a bounding box gives the distance of the bounding box to the observer. To represent relative depth we define the following relations on the depth function:

Further(x, y, t): “ x is further from the observer than y at time t ”;

Closer(x, y, t): “ x is closer to the observer than y at time t ”;

Depth.Equal(x, y, t): “ x is as far as y from the observer’s viewpoint at time t ”.

These relations are defined in (1).

$$\begin{aligned} \text{Further}(x, y, t) &\leftrightarrow (\text{depth}(x, t) > \text{depth}(y, t)) \wedge \\ &(|\text{depth}(x, t) - \text{depth}(y, t)| \geq \mu); \end{aligned} \quad (1a)$$

$$\begin{aligned} \text{Closer}(x, y, t) &\leftrightarrow (\text{depth}(x, t) < \text{depth}(y, t)) \wedge \\ &(|\text{depth}(x, t) - \text{depth}(y, t)| \geq \mu); \end{aligned} \quad (1b)$$

$$\begin{aligned} \text{Depth.Equal}(x, y, t) &\leftrightarrow \\ &(|\text{depth}(x, t) - \text{depth}(y, t)| < \mu). \end{aligned} \quad (1c)$$

¹We used a ternary version of these relations, where the third argument represents the timepoint when the relation holds.

Note that the relation *Closer/3* is the inverse of *Further/3*, i.e., $\text{Further}(x, y, t) \equiv \text{Closer}(y, x, t)$. This fact follows from the axioms and the definition of the order relation. We introduced two distinct relations in order to keep our definitions closer to the common sense usage of the concepts represented.

Motion Interpreted as Qualitative Change

Motion of bounding boxes is represented by making qualitative distinctions of the changes in bounding boxes parameters. In each of the formulae presented below the timepoint t falls within the the open time interval (t_1, t_2) . In this work, such time intervals are assumed to be very small; therefore, the predicates defined below are locally valid with respect to the time point t . We assume that this constraint is respected in this work but do not write it explicitly in the formulae for clarity. Further, we assume that there is a static relation between all relations to represent the case that the distance between two bounding boxes stays the same, which is the case where the bounding box does not change in size or relative position.

Dynamic Relations between Pairs of Bounding Boxes.

To represent relative movement of pairs of bounding boxes we integrate their connectedness in terms of topological relations into the relations on movement. We combined these two aspects to encounter the fact that a change in the topological relations is only possible due to relative motion of the bounding boxes as depicted by the conceptual neighborhood diagram [Freksa, 1991] in Fig. 2. For *approaching* bounding boxes the relations are:

$$\begin{aligned} \text{approaching_DR}(p, q, t) &\leftrightarrow \exists t_1 t_2 (t_1 < t) \wedge (t < t_2) \wedge \\ &\text{DR}(p, q, t_1) \wedge \text{DR}(p, q, t_2) \wedge \\ &(\text{dist}(p, q, t_2) < \text{dist}(p, q, t_1)); \end{aligned} \quad (2a)$$

$$\begin{aligned} \text{approaching_PO}(p, q, t) &\leftrightarrow \exists t_1 t_2 (t_1 < t) \wedge (t < t_2) \wedge \\ &(\text{DR}(p, q, t_1) \vee \text{PO}(p, q, t_1)) \wedge \text{PO}(p, q, t_2) \wedge \\ &(\text{dist}(p, q, t_2) < \text{dist}(p, q, t_1)); \end{aligned} \quad (2b)$$

$$\begin{aligned} \text{approaching_PP}(p, q, t) &\leftrightarrow \exists t_1 t_2 (t_1 < t) \wedge (t < t_2) \wedge \\ &(\text{PO}(p, q, t_1) \vee \text{PP}(p, q, t_1)) \wedge \text{PP}(p, q, t_2) \wedge \\ &(\text{dist}(p, q, t_2) < \text{dist}(p, q, t_1)); \end{aligned} \quad (2c)$$

$$\begin{aligned} \text{approaching_PPI}(p, q, t) &\leftrightarrow \exists t_1 t_2 (t_1 < t) \wedge (t < t_2) \wedge \\ &(\text{PO}(p, q, t_1) \vee \text{PPI}(p, q, t_1)) \wedge \text{PPI}(p, q, t_2) \wedge \\ &(\text{dist}(p, q, t_2) < \text{dist}(p, q, t_1)); \end{aligned} \quad (2d)$$

In the same way we define relations for pairs of *receding* bounding boxes.

$$\begin{aligned} \text{receding_DR}(p, q, t) \leftrightarrow \exists t_1 t_2 (t_1 < t) \wedge (t < t_2) \wedge \\ (DR(p, q, t_1) \vee PO(p, q, t_1)) \wedge DR(p, q, t_2) \wedge \\ (dist(p, q, t_2) > dist(p, q, t_1)); \end{aligned} \quad (2e)$$

$$\begin{aligned} \text{receding_PO}(p, q, t) \leftrightarrow \exists t_1 t_2 (t_1 < t) \wedge (t < t_2) \wedge \\ (PO(p, q, t_1) \vee PP(p, q, t_1) \vee \\ EQ(p, q, t_1) \vee PPI(p, q, t_1)) \wedge PO(p, q, t_2) \wedge \\ (dist(p, q, t_2) > dist(p, q, t_1)); \end{aligned} \quad (2f)$$

$$\begin{aligned} \text{receding_PP}(p, q, t) \leftrightarrow \exists t_1 t_2 (t_1 < t) \wedge (t < t_2) \wedge \\ (PP(p, q, t_1) \vee EQ(p, q, t_1)) \wedge PP(p, q, t_2) \wedge \\ (dist(p, q, t_2) > dist(p, q, t_1)); \end{aligned} \quad (2g)$$

$$\begin{aligned} \text{receding_PPI}(p, q, t) \leftrightarrow \exists t_1 t_2 (t_1 < t) \wedge (t < t_2) \wedge \\ (PPI(p, q, t_1) \vee EQ(p, q, t_1)) \wedge PPI(p, q, t_2) \wedge \\ (dist(p, q, t_2) > dist(p, q, t_1)); \end{aligned} \quad (2h)$$

In the case that two bounding boxes cover the same space the *equal* relation holds.

$$\begin{aligned} \text{approaching_EQ}(p, q, t) \leftrightarrow \exists t_1 t_2 (t_1 < t) \wedge (t < t_2) \wedge \\ (EQ(p, q, t_1) \vee PO(p, q, t_1) \vee PPI(p, q, t_1) \vee PP(p, q, t_1)) \wedge \\ EQ(p, q, t_2). \end{aligned} \quad (2i)$$

Note, this relation can not occur when representing solid and opaque individuals, like people, but occurs for other kinds of individuals like conceptual areas in the meeting domain.

Dynamic Relations on a Single Bounding Box. To represent single object motion, we consider the following relations on changes in bounding boxes size and visibility in the scene. *appearing* and *disappearing* represent the events of an bounding box being visible at time t but was not visible at the previous time point, resp. not being visible at time t but has been visible at the previous time point;

$$\begin{aligned} \text{appearing}(p, t) \leftrightarrow \exists t_1 t_2 (t_1 < t) \wedge (t < t_2) \wedge \\ \neg in_sight(p, t_1) \wedge in_sight(p, t_2). \end{aligned} \quad (3a)$$

$$\begin{aligned} \text{disappearing}(p, t) \leftrightarrow \exists t_1 t_2 (t_1 < t) \wedge (t < t_2) \wedge \\ in_sight(p, t_1) \wedge \neg in_sight(p, t_2). \end{aligned} \quad (3b)$$

extending and *shrinking* means the height of the bounding box extends / shrinks at the same rate as its width;

$$\begin{aligned} \text{extending}(p, t) \leftrightarrow \exists t_1 t_2 (t_1 < t) \wedge (t < t_2) \wedge \\ \frac{\Delta(H)}{\Delta(W)} = 1 \wedge (height(p, t_1) < height(p, t_2)) \wedge \\ (width(p, t_1) < width(p, t_2)). \end{aligned} \quad (3c)$$

$$\begin{aligned} \text{shrinking}(p, t) \leftrightarrow \exists t_1 t_2 (t_1 < t) \wedge (t < t_2) \wedge \\ \frac{\Delta(H)}{\Delta(W)} = 1 \wedge (height(p, t_1) > height(p, t_2)) \wedge \\ (width(p, t_1) > width(p, t_2)). \end{aligned} \quad (3d)$$

h-elongating and *h-shortening* represent the cases where the height of the bounding box elongates / shortens at a distinct rate than its width;

$$\begin{aligned} \text{h_elongating}(p, t) \leftrightarrow \exists t_1 t_2 (t_1 < t) \wedge (t < t_2) \wedge \\ \frac{|\Delta(H)|}{|\Delta(W)|} > 1 \wedge (height(p, t_1) < height(p, t_2)). \end{aligned} \quad (3e)$$

$$\begin{aligned} \text{h_shortening}(p, t) \leftrightarrow \exists t_1 t_2 (t_1 < t) \wedge (t < t_2) \wedge \\ \frac{|\Delta(H)|}{|\Delta(W)|} > 1 \wedge (height(p, t_1) > height(p, t_2)). \end{aligned} \quad (3f)$$

Similar *w-elongating* and *w-shortening* represents that the width elongates / shortens at a distinct rate than its height.

$$\begin{aligned} \text{w_elongating}(p, t) \leftrightarrow \exists t_1 t_2 (t_1 < t) \wedge (t < t_2) \wedge \\ \frac{|\Delta(H)|}{|\Delta(W)|} < 1 \wedge (width(p, t_1) > width(p, t_2)). \end{aligned} \quad (3g)$$

$$\begin{aligned} \text{w_shortening}(p, t) \leftrightarrow \exists t_1 t_2 (t_1 < t) \wedge (t < t_2) \wedge \\ \frac{|\Delta(H)|}{|\Delta(W)|} < 1 \wedge (width(p, t_1) < width(p, t_2)). \end{aligned} \quad (3h)$$

Domain Dependent Spatial Change

To describe the observed scene in terms of spatio-temporal phenomena we combine the different aspects of the theory about space and motion providing a rich vocabulary about qualitative changes in the visual domain. This allows us to describe the ongoing actions and operations between pairs of bounding boxes as well as on single bounding boxes. The observations combining one or more aspects of space represent domain dependent phenomena and assume certain properties of the represented individuals.

Visibility with Respect to the Observer. Topological relations of the bounding box's projection on the image plane, can be interpreted as visibility from the observers point of view [Randell *et al.*, 2001]. We use this fact to represent that one bounding box is occluded by another bounding box, e.g., p is *partially-occluded* by q , if p and q are partially overlapping, and p is *further than* q :

$$\begin{aligned} \text{partially_occluded}(p, q, t) \leftarrow \\ \text{Further}(p, q, t) \wedge PO(p, q, t). \end{aligned} \quad (4a)$$

$$\begin{aligned} \text{disappearing_partially_occluded}(p, q, t) \leftarrow \\ \text{disappearing}(p, t_2) \wedge PO(p, q, t_1) \wedge \text{Further}(p, q, t_1). \end{aligned} \quad (4b)$$

$$\begin{aligned} \text{appearing_partially_occluded}(p, q, t) \leftarrow \\ \text{appearing}(p, t) \wedge PO(p, q, t) \wedge \text{Further}(p, q, t). \end{aligned} \quad (4c)$$

These relations only hold under the assumption that the represented individuals are ridged and non-opaque.

Direction of Movement. We represent relative moving directions by combining relations on extrinsic orientation (left/right) with relations on movement.

$$\begin{aligned} \text{approaching_left}(p, q, t) \leftarrow \\ \text{approaching_DR}(p, q, t) \wedge \text{left_of}(p, q, t). \end{aligned} \quad (5a)$$

$$\begin{aligned} \text{approaching_right}(p, q, t) \leftarrow \\ \text{approaching_DR}(p, q, t) \wedge \text{right_of}(p, q, t). \end{aligned} \quad (5b)$$

Movement with Respect to the Observer. We represent relative movement of a bounding box with respect to the observer by introducing distinct objects for the observer as well as the borders of the cameras field of view. These objects are represented as static bounding boxes in the scene. We represent movement of bounding boxes using the relations *approaching* and *receding*.

$$\begin{aligned} \text{moving_left}(p, t) \leftarrow \\ \text{approaching_DR}(p, \text{left_border}, t) \vee \\ \text{approaching_PO}(p, \text{left_border}, t). \end{aligned} \quad (6a)$$

$$\begin{aligned} \text{moving_right}(p, t) \leftarrow \\ \text{approaching_DR}(p, \text{right_border}, t) \vee \\ \text{approaching_PO}(p, \text{right_border}, t). \end{aligned} \quad (6b)$$

In this way we define the relations for: (1). *coming closer*: the object moves towards the observer; (2). *going further away*: the object moves away from the observer; (3). *moving left / right*: the object approaches the left / right border of the field of view.

Interaction	Interpretation
passing front (pf)	person P is passing in front of person Q
passing behind (pb)	person P is passing behind person Q
enter FoV (e)	person P enters the cameras field of view
leave FoV (l)	person P leaves the cameras field of view
stand up (su)	person P stands up
sit down (sd)	person P sits down
raise hand (rh)	person P raises a hand

Table 1: Hypotheses explaining the changes in the relations between bounding boxes

Demonstration Scenario

We demonstrate the applicability of the theory of depth, space, and motion and the HMM-generated hypotheses in the context of the meeting scenario (Fig. 1). In this context, the basic interactions involved in the meeting process in Table 1 are considered.

Hypotheses on Perceived Change. Each of the predicates on changes in bounding boxes attributes are results of changes that occurred with objects in the world (including noise). In this section we loosely associate the predicates with possible hypotheses on object changes. In the meeting scenario, we assume that the camera is fixed in its position and orientation. Thus the changes observed in the relations are only due to object’s motion (or noise in the sensor data). We use HMM to interpret observed spatial change in terms of interactions of individuals in the environment. As proposed by [Chua *et al.*, 2009] we generate one model for each hypothesis and use the forward algorithm to compute the probability that the observed changes are the result of a specific interaction. To handle multiple people involved in an interaction, we use a separate model for each of the involved persons. To find the most certain hypotheses we compute the probability values for each single interaction and for each component of the pair interactions (Alg. 1). To determine the best hypotheses we choose the HMM that produced the highest probabilities for single interactions or combine the probabilities for hypotheses involving multiple persons by computing their mean value.

Data Recording. We recorded a staged meeting situation using the RGB and depth sensing capabilities of the Kinect sensor. We collected two data sets of up to four interacting people. The number of instances for each interaction vary between 10 and 30 in one set, as the data was collected in a natural meeting situation. The interactions are performed in random order throughout the recording.

Tracking and Noise. To track the people in the scene we use the people tracking capabilities of the Kinect. The result of the tracking suffers from noise appearing as ‘jitter’ in the values for depth, size, and position, and in bigger changes when the region of a person mixes with other objects at the same depth. This results in wrong relations obtained from the data. The tracking algorithm provides basic capabilities to recognize reappearance of people pertain their identity; however, this is not stable as it tends to miss reappearing individuals. This also occurs when a person is only shortly invisible for the device, e.g. due to occlusion, and results in connected observation sequences having different identity tags.

Algorithm 1: Generating Hypotheses on Object Relations

```

Data:  $P, (P, Q)$ : Bounding Boxes;
 $HMM_p, HMM_{p,q}$ : Hidden Markov Models;
 $T$ : Theory about Depth, Space, and Motion;
Result:  $Prob_a$ : Activity Probabilities
begin
  for each  $P$  do
     $Obs_p \leftarrow getObs(p, T)$ ;
    for each  $HMM_p$  do
       $Prob_p \leftarrow Forward(HMM_p, Obs_p)$ ;
  for each  $(P, Q)$  do
     $Obs_{p,q} \leftarrow getObs(p, q, T)$ ;
    for each  $HMM_{pq}$  do
       $Prob_{p,q} \leftarrow Forward(HMM_{p,q}, Obs_{p,q})$ ;
   $Prob_a \leftarrow Calc\_mean(Prob_p, Prob_{p,q})$ 

```

		hypotheses						
		pf	pb	e	l	su	sd	rh
ground truth	pf'	75%	25%	0	0	0	0	0
	pb'	0	81%	0	0	0	0	0
	e'	0	4%	89%	0	0	0	0
	l'	0	0	0	79%	0	0	3%
	su'	0	9%	0	0	64%	0	18%
	sd'	0	0	0	0	0	73%	9%
	rh'	0	0	0	4%	8%	21%	54%

Table 2: Confusion matrix for the generated hypotheses.

Training Setup. To generate the hypotheses we defined two sets of 10 observations based on the theory of depth, space, and motion; one for single bounding boxes and one for pairs of bounding boxes. For the training of the hidden markov models we used one of the collected datasets and extracted the defined observations. The hypotheses we generate are independent of the direction of movement involved in the interaction, thus we include a vertically mirrored set of the observations into the trainings set, to avoid a bias in the results dependent on the direction. For testing the hypotheses we used the remaining dataset and extracted observations sequences which were used to generate the hypotheses by the HMM. As we focus on generating hypotheses based on observed change and the descriptive capabilities of the theory, we neglect the problem of finding the start and the end point of an activity and assume that we have an appropriate sequence of observations.

Performance. We show the generated hypotheses with respect to the ground truth information in the confusion matrix in Tab. 2. The rows represent the correct interpretation while the columns denote the generated hypotheses. Our method to generate the hypotheses allows to make the hypotheses that the observations correspond to no relevant interaction, which is not represented in the confusion matrix. Therefore the sum

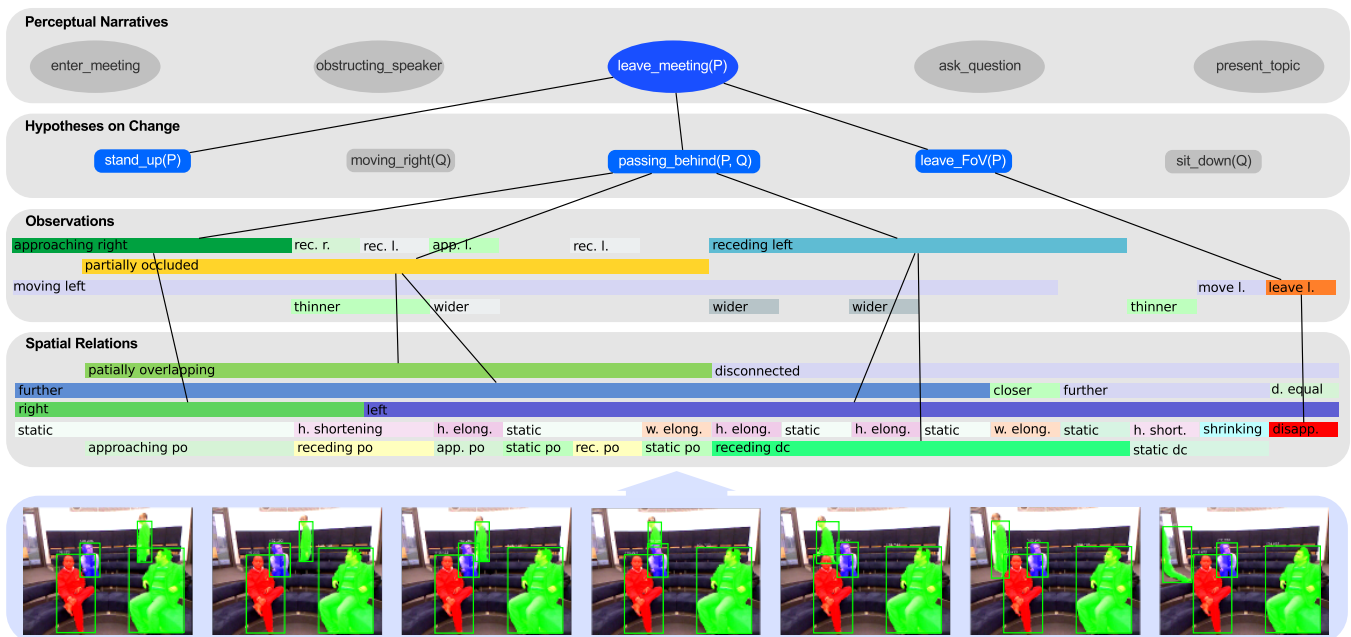

Figure 3: Perceptual Narratives of Depth, Space, and Motion

of the percentage in the rows does not add up to 100.

Stand up, sit down, and raise hand are confused as all these interactions are primarily represented by changes in the bounding boxes height. To improve the performance for these interactions, we have to extend the theory by relations on the inside of the bounding boxes. P passing in front of Q is mistaken for Q passing behind P, as these interactions only differ in the relative movement to the camera's field of view. And also some instances of leaving and entering the field of view are not interpreted correctly. For these cases a bigger training set with a greater range of observations would help to refine the results. Furthermore the integration of commonsense rules about objects in the domain can help to reduce the noise in the observation drastically. E.g. changing identity tags when passing behind or occluding persons can most likely be reduced by modelling domain constraints in the theory about depth, space, and motion. Specially interesting in this context are: *object persistence*, *continuity*, and *substantiality* [Siskind, 1995].

Conclusion and Outlook

Hypothesised object relations can be seen as building blocks to form complex interactions that are semantically interpreted as activities in the context of the domain. As an example consider the sequence of observations in the meeting environment depicted in Fig. 3.

Region P **elongates vertically**, region P **approaches** region Q from the **right**, region P **partially overlaps** with region Q while P being **further away** from the observer than Q, region P **moves left**, region P **recedes** from region Q at the **left**, region P gets **disconnected** from region Q, region P **disappears** at the left border of the field of view

To explain these observations in the 'context' of the meeting situation we make hypothesis about possible interactions in the real world.

Person P **stands up**, **passes behind** person Q while **moving towards** the exit and **leaves** the room.

Toward the generation of (declaratively grounded) perceptual narratives [Bhatt *et al.*, 2013b] such as the above, we developed and implemented a commonsense theory of qualitative space, depth, and motion for abstracting and reasoning about dynamic scenes. We defined combined relations capturing different spatial modalities in the context of a benchmark domain, namely the smart meeting cinematography scenario of the ROTUNDE initiative [Bhatt *et al.*, 2013a]. As a proof of concept, we integrated our proposed theory with Hidden Markov Models to recognize the activities performed in the smart meeting scenario based on the combined model of space, depth, and change.

The smart meeting cinematography scenario serves as a challenging benchmark to investigate narrative based high-level cognitive interpretation of everyday interactions. Work is in progress to release certain aspects (pertaining to space, motion, real-time high-level control) emanating from the narrative model via the interface of constraint logic programming (e.g., as a Prolog based library of depth-space-motion).

Perceptual narrative based scene interpretation will be used for cognitive camera control consisting of interpreting the observations to identify important information and plan control actions based on the spatial requirements and constraints of scene. Work towards this end includes the integration of multiple camera viewpoints, where the system has to reason about perspective changes and visibility based on qualitative spatio-temporal abstractions.

References

- [Bhatt *et al.*, 2011a] M. Bhatt, H. Guesgen, S. Wöflf, and S. Hazarika. Qualitative spatial and temporal reasoning: Emerging applications, trends, and directions. *Spatial Cognition & Computation*, 11(1):1–14, 2011.
- [Bhatt *et al.*, 2011b] Mehul Bhatt, Jae Hee Lee, and Carl Schultz. CLP(QS): A Declarative Spatial Reasoning Framework. In *COSIT*, pages 210–230, 2011.
- [Bhatt *et al.*, 2013a] Mehul Bhatt, Jakob Suchan, and Christian Freksa. ROTUNDE – A Smart Meeting Cinematography Initiative. In M. Bhatt, H. Guesgen, and D. Cook, editors, *Proceedings of the AAAI-2013 Workshop on Space, Time, and Ambient Intelligence (STAMI)*, Washington, US, 2013. AAAI Press. (to appear).
- [Bhatt *et al.*, 2013b] Mehul Bhatt, Jakob Suchan, and Carl Schultz. Cognitive interpretation of everyday activities – toward perceptual narrative based visuo-spatial scene interpretation. In Benedikt Lwe. J. C. Meister M. Finlayson., B. Fisseni., editor, *Computational Models of Narrative (CMN) 2013*, 2013.
- [Bhatt, 2012] Mehul Bhatt. Reasoning about space, actions and change: A paradigm for applications of spatial reasoning. In *Qualitative Spatial Representation and Reasoning: Trends and Future Directions*. IGI Global, USA, 2012.
- [Chua *et al.*, 2009] Sook-Ling Chua, Stephen Marsland, and Hans W Guesgen. Behaviour recognition from sensory streams in smart environments. In *Proceedings of the 22nd Australasian Joint Conference on Advances in Artificial Intelligence, AI '09*, pages 666–675, Berlin, Heidelberg, 2009. Springer-Verlag.
- [Cohn and Renz, 2007] A G Cohn and J Renz. Qualitative spatial reasoning. In Frank van Harmelen, Vladimir Lifschitz, and Bruce Porter, editors, *Handbook of Knowledge Representation*. Elsevier, 2007.
- [Cohn *et al.*, 1997] Anthony G. Cohn, Brandon Bennett, John Gooday, and Nicholas Mark Gotts. Qualitative spatial representation and reasoning with the region connection calculus. *Geoinformatica*, 1(3):275–316, October 1997.
- [Dee *et al.*, 2012] Hannah M. Dee, Anthony G. Cohn, and David C. Hogg. Building semantic scene models from unconstrained video. *Computer Vision and Image Understanding*, 116(3):446–456, 2012.
- [dos Santos *et al.*, 2009] M.V. dos Santos, R. C. de Brito, H-H Park, and P. Santos. Logic-based interpretation of geometrically observable changes occurring in dynamic scenes. *Applied Intelligence*, 31(2):161–179, 2009.
- [Dubba *et al.*, 2010] Krishna S. R. Dubba, Anthony G. Cohn, and David C. Hogg. Event model learning from complex videos using ILP. In *ECAI*, pages 93–98, 2010.
- [Duong *et al.*, 2009] Thi Duong, Dinh Phung, Hung Bui, and Svetha Venkatesh. Efficient duration and hierarchical modeling for human activity recognition. *Artif. Intell.*, 173(7-8):830–856, 2009.
- [Fernyhough *et al.*, 2000] Jonathan H. Fernyhough, Anthony G. Cohn, and David Hogg. Constructing qualitative event models automatically from video input. *Image Vision Comput.*, 18(2):81–103, 2000.
- [Freksa, 1991] Christian Freksa. Conceptual neighborhood and its role in temporal and spatial reasoning. In *Decision support systems and qualitative reasoning*, pages 181–187. North-Holland, 1991.
- [Gonzlez *et al.*, 2012] Jordi Gonzlez, Thomas B. Moeslund, and Liang Wang, editors. *Computer Vision and Image Understanding*, volume 116, chapter Special issue on Semantic Understanding of Human Behaviors in Image Sequences, pages 305–472. Elsevier, 2012.
- [Lavee *et al.*, 2009] G. Lavee, E. Rivlin, and M. Rudzsky. Understanding video events: A survey of methods for automatic interpretation of semantic occurrences in video. *Systems, Man, and Cybernetics, Part C: Applications and Reviews, IEEE Transactions on*, 39(5):489–504, 2009.
- [Liao *et al.*, 2005] Lin Liao, Dieter Fox, and Henry A. Kautz. Location-based activity recognition using relational markov networks. In *IJCAI*, pages 773–778, 2005.
- [Ligozat, 2013] G. Ligozat. *Qualitative Spatial and Temporal Reasoning*. ISTE. Wiley, 2013.
- [Menon *et al.*, 2008] V. Menon, B. Jayaraman, and V. Govindaraju. Integrating recognition and reasoning in smart environments. In *Intelligent Environments, 2008 IET 4th International Conference on*, pages 1–8, July 2008.
- [Morariu and Davis, 2011] V.I. Morariu and L.S. Davis. Multi-agent event recognition in structured scenarios. In *IEEE Conference on Computer Vision and Pattern Recognition (CVPR)*, pages 3289–3296, june 2011.
- [Philipose *et al.*, 2004] Matthai Philipose, Kenneth P. Fishkin, Mike Perkowitz, Donald J. Patterson, Dieter Fox, Henry Kautz, and Dirk Hahnel. Inferring activities from interactions with objects. *IEEE Pervasive Computing*, 3(4):50–57, October 2004.
- [Poppe, 2010] Ronald Poppe. A survey on vision-based human action recognition. *Image and Vision Computing*, 28(6):976–990, 2010.
- [Randell *et al.*, 1992] David A. Randell, Zhan Cui, and Anthony Cohn. A spatial logic based on regions and connection. In *KR'92. Principles of Knowledge Representation and Reasoning*, pages 165–176. Morgan Kaufmann, San Mateo, California, 1992.
- [Randell *et al.*, 2001] D. Randell, M. Witkowski, and M. Shanahan. From images to bodies: Modeling and exploiting spatial occlusion and motion parallax. In *Proc. of IJCAI*, pages 57–63, Seattle, U.S., 2001.
- [Schmitz *et al.*, 2012] Bernhard Schmitz, Attila Györkös, and Thomas Ertl. Combination of map-supported particle filters with activity recognition for blind navigation. In *ICCHP (2)*, pages 529–535, 2012.
- [Siskind, 1995] J. M. Siskind. Grounding language in perception. *Artificial Intelligence Review*, 8(5-6):371–391, 1995.
- [Sridhar *et al.*, 2010] Muralikrishna Sridhar, Anthony G. Cohn, and David C. Hogg. Unsupervised learning of event classes from video. In *AAAI*, 2010.
- [Tran and Davis, 2008] Son D Tran and Larry S Davis. Event modeling and recognition using markov logic networks. In *ECCV '08 Proceedings of the 10th European Conference on Computer Vision: Part II*, 2008.
- [Velastin *et al.*, 2005] Sergio A. Velastin, Boghos A. Boghossian, Benny Ping Lai Lo, Jie Sun, and Maria Alicia Vicencio-Silva. PRISMATICA: toward ambient intelligence in public transport environments. *IEEE Transactions on Systems, Man, and Cybernetics. Part A: Systems and Humans*, 35(1):164–182, 2005.
- [Youngblood and Cook, 2007] G. Michael Youngblood and Diane J. Cook. Data mining for hierarchical model creation. *IEEE Transactions on Systems, Man, and Cybernetics, Part C*, 37(4):561–572, 2007.

Using Narrative Function to Extract Qualitative Information from Natural Language Texts: A Preliminary Report

Clifton McFate, Kenneth D. Forbus, Thomas R. Hinrichs

Qualitative Reasoning Group, Northwestern University

2133 Sheridan Road, Evanston, IL 60208, USA

Mcfateclifton79@gmail.com, {forbus, t-hinrichs}@northwestern.edu

Abstract

The naturalness of qualitative reasoning suggests that qualitative representations might be an important component of the semantics of natural language. Prior work (Kuehne 2004) showed that frame-based representations of qualitative process theory constructs could indeed be extracted from natural language texts. Kuehne’s approach relied on the parser recognizing specific syntactic constructions, which has limited coverage. This paper describes a new approach, using *narrative function* to represent the higher-order relationships between the constituents of a sentence and between sentences in a discourse. We outline how narrative function combined with query-driven abduction enables the same kinds of information to be extracted from natural language texts. Moreover, we also show how type-level qualitative representations (Hinrichs & Forbus, 2012) can be extracted from text, and used to improve performance in playing a strategy game.

1 Introduction

Qualitative representations were developed in part to serve as a formal language for expressing the contents of human mental models about continuous systems. Since such knowledge is often expressed in natural language, it makes sense to explore how qualitative representations might be used in natural language semantics. Kuehne (2004) showed that the constructs of qualitative process theory (Forbus, 1984) could be recast in a frame-based representation, compatible with the frame semantic representations used in Fillmore et al.’s (2001) FrameNet. In frame semantics, frames represent conceptual structures that are connected to lexical items through *frame elements*, i.e. slots in the frame. For example, the notion of qualitative proportionality is captured by an Indirect Influence frame, which includes the following frame elements:

- *Constrainer*: The antecedent quantity of the causal relationship

- *Constrained*: The quantity being constrained by this relationship
- *Sign*: The direction of change

Kuehne (2004) identified a set of phrasal patterns that could be identified by syntactic parsers and used to extract QP information from natural language texts. Here is an example of such a pattern:

AS <Quantity1> <Change1>, <Quantity2>
<Change2>.

“As the **temperature** of the steam **rises**, the **pressure** inside the boiler **rises**”

In the example above, the constrainer would be a quantity frame representing the temperature of the steam, the constrained would be a quantity frame representing the pressure inside the boiler, and since both of the changes are a form of increasing, the sign would be positive. For each representational element in QP theory (i.e. quantities, ordinals, influences, and processes), Kuehne identified a set of syntactic patterns that could be used to extract them from text. The syntactic patterns were encoded into the grammar of the parser, which is capable of using semantic constituents (e.g. sub-elements identified as quantities) in its rules. The extracted knowledge was further transformed by antecedent rules to construct QP frame representations. While this was a successful proof of concept demonstration, when trying to scale this up for use in systems that learn by reading, we discovered several limitations. First, the use of syntactic patterns significantly limited coverage. Second, the antecedent rules used to merge coreferential frames did not scale well to larger texts.

This paper describes a different approach, based on *narrative function*, for extracting QP information from text. We start by explaining the idea of narrative function and the key properties of the natural language understanding system used. Then we show how QP frames can be constructed by deriving narrative functions, and that this approach already captures almost all of the range of examples handled previously. Moreover, we show how narrative function can be used to extract type-level influences (Hinrichs & Forbus,

2012) from natural language, and that such information can significantly improve the performance of a system playing a strategy game. We close with future work.

2 Narrative Function and Abduction

When people read, they try to see how what they are reading fits together. At the beginning of a story, characters are introduced, and expectations raised about possible events that might occur. If a fable involves a fox and a goose meeting on a riverbank, for example, one possible outcome of that meeting is that mayhem ensues. Narrative function provides a representation that ties the contents of specific sentences to the ongoing discourse. Introducing a character is a narrative function, as is introducing an event and raising expectations about possible outcomes of that event.

Tomai (2009) showed that narrative functions could be used in understanding natural language texts such as fables and the materials used in psychological studies of social cognition and moral decision-making. Since qualitative information is part of what is conveyed in language, e.g. explanations of continuous systems, such as found in textbooks, it stands to reason that such information needs to be linked into the general-purpose representations for understanding the intended purpose of a sentence within a discourse. Thus it makes sense to expand the range of narrative functions to include detecting the introduction of QP information. Section 3 describes these new narrative functions. But first, we provide some relevant background about the natural language system, EA NLU.

2.1 EA NLU and Choice Sets

The Explanation Agent Natural Language Understanding System (EA NLU; Tomai & Forbus, 2009) uses a syntactic parser (Allen, 1994) and lexical information from COMLEX (Grishem et al. 1993) and ResearchCyc¹ for syntactic processing. It uses representations from ResearchCyc for its semantics, including an implementation of Discourse Representation Theory (Kamp & Reyle, 1993) that uses Cyc microtheories to handle contexts.

Like other NLU systems, EA NLU introduces *choice sets* to represent ambiguities. Choice sets are introduced when there are multiple meanings of a word, or multiple parses. Consider for example this discourse:

Q: "How many children does Mary have?"

A: "She has 3 kids."

The term *kid* is ambiguous. It could be a child, or it could be a baby goat, as these choices from the KB indicate:

```
(isa kid5283 HumanChild)
(isa kid5283 (JuvenileFn Goat))
```

Here *kid5283* is a *discourse variable*, an arbitrary individual introduced to represent whatever it is that "kid" refers to. This is an example of a *word sense* choice set. The other kind of choice set produced by EA NLU concerns parsing choices, e.g. where a prepositional phrase should be attached. Semantic interpretation involves selecting an element from each choice set implied by the linguistic analysis of the sentence. This can be quite complex: For example, choices in some choice sets might imply the existence of further choice sets to be considered. In general, semantic interpretation is an unsolved problem. Strategies like backtracking search have been tried, but they flounder on the large number of possible interpretations. Interestingly, psycholinguistic research suggests that people are quite rapid readers, and seem to do long-range backtracking very rarely. There are many possible explanations for this, including performing evidential reasoning to select the most likely choices. Another source of constraint is context, which provides expectations. Here, the first interpretation of "kid" would be more sensible, because "She" presumably is co-referential with "Mary", and since the question spoke of "children", we might assume that Mary is human. Therefore (trans-genetic experiments notwithstanding) Mary's child is most likely human. This choice supports the second statement being an answer to the first, which is an example of narrative function in action.

2.2 Abduction

EA NLU uses a novel query-driven abduction process to provide top-down guidance to the process of semantic interpretation. Abduction is inference to a plausible explanation. That is, if $P \Rightarrow Q$, then an explanation for Q being observed is that P is true. Obviously there could be other explanations for Q , so abduction is not deductively valid, and relies on heuristics for estimating the plausibility of abductive assumptions. Abduction has long been used in semantic interpretation (Hobbs 2004), but it tends to be intractable as the number of statements grows. Tomai (2009) showed that by using top-down expectations, e.g. looking for a moral choice, the complexity of abduction over a discourse could be greatly reduced, since many potential choices could simply be ignored.

The abduction mechanism in EA NLU only makes assumptions about what choices should be made from the choice sets presented by linguistic analysis. It is driven by queries, which are generated based on overall context of the task as well as specifics in the data. To identify the set of queries to be made, it first does a query of the form

```
(queryForInterpretation ?o ?q)
```

?q is a query that should be made in the interpretation context for the current sentence. ?o is an integer that provides advice about the ordering of queries. All queries with lower values for order will be done before any query

¹ <http://www.cyc.com/platform/researchcyc>

with a higher value for order. Thus, for example, the rules searching for influences can be assured that any quantity information already existing in the discourse will have been found. We call this mechanism *query for questions*.

The abduction mechanism is tuned for specific tasks and contexts in two ways. First, all analyses are done with respect to a logical environment, defined by a current microtheory and all of the microtheories it inherits from. This includes microtheories that specify what questions make sense for that task via *queryForInterpretation* statements. Second, the algorithm retrieves declarative advice from the logical environment as to what sorts of interpretation are preferred. For example, interpretations which include QP information are preferred, which biases the system toward interpretations that produce this sort of information. This approach differs from that of more lexically oriented abductive NLU systems such as (Ovchinnikova 2012). Ovchinnikova’s abductive NLU system operates over a knowledge base extracted from WordNet and FrameNet and uses lexical knowledge to weight abductive inferences. Our approach instead focuses on how discourse and narrative goals can guide abductive inference. Of course, the two approaches are not mutually exclusive and future work will certainly focus on incorporating more word and sentence level pragmatic knowledge.

2.3 Representing Narrative Functions

The connection between a piece of sentence content and its role in the narrative is expressed via

```
(narrativeFunction ?PE ?C ?T)
```

where ?PE is a *presentation event*, i.e. the narrative-level event being described, ?C is the content of that event, and ?T is the type of narrative event. A sentence can give rise to multiple narrative functions, so presentation events are represented via non-atomic terms as follows:

```
(PresentationEventFn <sentence ID>
  ?eventID)
```

where <sentence ID> is substituted into each query processed by the query for questions mechanism outlined above, and ?eventID is a unique identifier constructed by whatever rule introduces the presentation event. In the case of QP language interpretation, the content of events are particular types of QP frames and the types are from an ontology outlined below.

3 Finding QP Frames via Abduction of Narrative Function

This section outlines the narrative functions for QP frames that we have developed, and summarizes some important properties of the rules that derive them from the natural language analysis of texts.

Quantities	IntroductionOfQuantityEvent
Topological Constraints	IntroductionOfTopologyConstraint
Derivative Sign	IntroductionOfDsInformation
Ordinals	IntroductionOfOrdinalEvent
Indirect Influence	IntroductionOfQPropEvent
Direct Influence	IntroductionOfDirectInfluenceEvent
Quantity Transfer	IntroductionOfQuantityTransferFrame
Process Frame	IntroductionOfProcess
Process Roles	IntroducesProcessRole

Table 1: QP Narrative Functions

3.1 QP Specific Narrative Functions

For each QP Frame type, we introduce a category of narrative function (see Table 1). For example, the following query kicks off the search for quantities:

```
(queryForInterpretation 0
 (narrativeFunction
  (PresentationEventFn :REPLACE-SID ?event-id)
  ?quantity-frame
  IntroductionOfQuantityEvent))
```

The order information associated with a query is used to organize the computation so that higher-order narrative functions are only sought after their potential constituents have been identified. For example, participants and consequences of continuous processes are sought after quantities have been found, and also after ordinal relationships have been detected, e.g.

```
(queryForInterpretation 3
 (narrativeFunction
  (PresentationEventFn :REPLACE-SID ?event-id)
  ?process-frame-role IntroducesProcessRole))
```

In addition to the QP Frame types proposed by Kuehne (2004) we created a frame for describing topological constraints on a system such as connections, interruptions, and paths. In the sentence:

“Water flows through a pipe.”

The path of the flow, the pipe, would be represented in a topological constraint frame. This separation was necessary as topological constraints on physical systems can frequently appear in text separated from the physical event that they constrain. An example would be:

“Cylinder A1 is connected to Cylinder A2 by a pipe.”
“Water flows from Cylinder A1 to A2.”

3.2 Basic QP Frame Extraction

Solutions to narrativeFunction are found via Horn clause rules which are similar to Prolog rules. They are different in that there is no notion of cut and all solutions are found. These rules analyze the predicate calculus statements produced by the parser, including lexical, syntactic, and semantic information. For example, a common indicator of a quantity is a phrase like “temperature in the reactor”. The prepositional phrase involving “in” leads to the parser producing a statement with the predicate `in-UnderspecifiedContainer`. This is a high-level Cyc predicate that covers a large space of more specific possibilities. When the phrase that is being modified is a type of continuous quantity, a rule looking for this combination hypothesizes a quantity frame whose entity is the discourse variable for the noun in the prepositional phrase and whose QType is the continuous quantity type.

Other rules require more type-level reasoning. For example, phrases that mention a substance inside a container often are references to the amount of that substance inside the container, e.g., “the steam in the boiler”. However, we cannot allow all containment statements to be quantities, e.g. “I am in a state of shock” is not a quantity statement. We distinguish between these cases by requiring the entity to be an instance of `ChemicalSubstanceType`. There are yet more complex cases, even for quantities. Some quantities are implied, e.g., “the hot brick.” Adjectives like *hot* often modify a specific quantity type, so such cases are handled by looking for quantity slots (e.g. `temperatureOf`) and connections between values (e.g. “hot”) and quantity types (e.g. `Temperature`).

3.3 Discourse Level QP Frames

Process Frames and Quantity Transfer Frames both require information from lower-level QP frames such as quantities. Thus narrative functions for these frames are sought after low-level queries have been completed. However, a hallmark of natural language is that it often provides only partial information about a situation. Thus not all of the constituents may be available, which is why frame representations are so useful in semantics. For example, we may know that there is a process going on based on the use of a process verb, but the sentence may not provide enough information to generate direct influences or qualitative proportionalities.

Another complexity is that higher level frames often combine information across sentences. Consider the following two sentences which, together, entail a quantity transfer:

“Heat flows from the hot brick”.

“Heat flows to the cool ground”.

Understanding the quantity transfer frame implicit in the above sentences requires recognizing that the *flow* event in both sentences is the same. This would also suggest that the *heat* is the same. Only then do the two direct influences implied by the pair form source and destination assertions.

Kuehne (2004) used antecedent rules to merge quantity frames both within and across sentences. Instead, we extended the abductive coreference algorithm of (Tomai 2009) to include verb coreference. This works by searching for multiple verbs that have the same event type and root.

An analysis of a broader range of texts revealed an interesting assumption implicit in Kuehne’s analysis of direct influences. The sentences above would have resulted in a single rate parameter, i.e. the rate of transfer of heat from the brick to the ground is the same. However, consider the following sentences:

“Heat flows from the hot coffee.”

“The heat flows to the cold ice cubes and the cool mug.”

In the above, the *flow* events may be coreferent.

However, assuming energy conservation, the rate of heat transfer from the coffee cannot be the same as the rate of transfer to the ice cubes and to the rate of transfer to the mug. Because of this, while we merge coreferent events, we do not merge coreferent rates: Another direct influence could always come along in the next sentence. Instead, we assume that downstream reasoning should be used to introduce such assumptions, based on closed-world assumptions over the material being read.

3.4 Evaluation

The system was evaluated using eight gold-standard QP examples from (Kuehne 2004). The texts covered all possible types of QP frames and several were multiple sentences long. The QP frames produced by the two systems were compared. For example, Figure 1 is a graphical depiction of the QP frames produced for the sentence “Heat flows from the brick.”

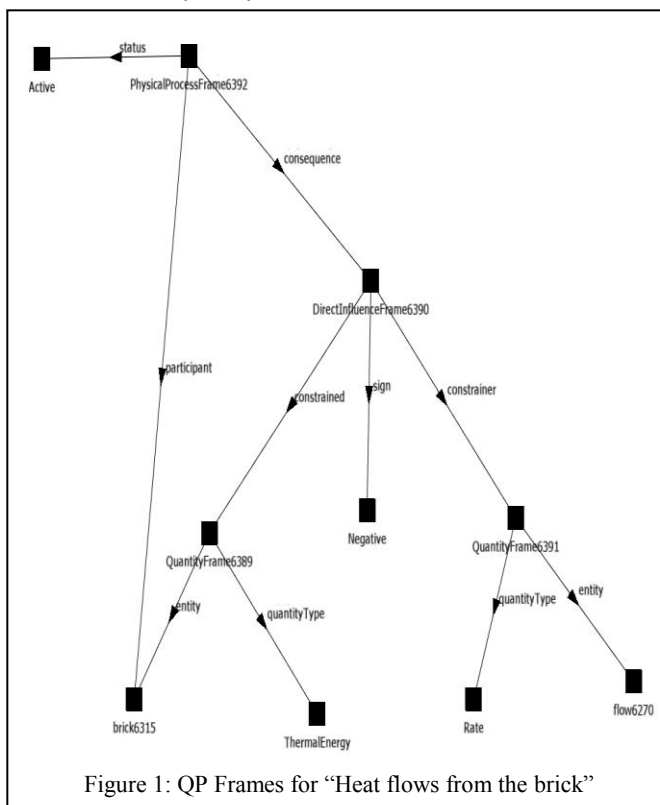

Figure 1: QP Frames for “Heat flows from the brick”

Currently, the system performs accurately on seven of eight examples. The incorrect example fails due to errors in coreference resolution. The other limitation is that we do not currently implement the Preconditions frame element for process frames. Other than those two differences, the results are compatible with Kuehne (2004).

4 Narrative Functions for Type-level Influences

Recently QP theory was expanded to include *type-level influences* (Hinrichs & Forbus, 2012). Type level influences are a form of higher-order qualitative reasoning, expressed in terms of causal relationships between predicates and concepts, rather than specific individuals. Type-level influences can provide significant benefit in large-scale domains and planning tasks. For example, the strategy game Freeciv², an open-source version of the classic computer game Civilization, provides a rich environment for experimenting with how qualitative reasoning can be used for modeling the kinds of reasoning and learning involved in understanding economics, strategies, and tactics. In Freeciv players build civilizations by founding cities, researching new technologies, improving the land around their cities, and building settlers to found new cities, to expand their civilization further. Such games are far more complex than chess, for example, and require many hours to learn. Interestingly, important advice can often be expressed in language whose semantics is well captured by type-level influences. For example, the statement

“Adding a university in a city increases its science output”

can be formally expressed via this type-level influence:

```
(positivelyDependsOn-TypeType
 (MeasurableQuantityFn cityScienceTotal)
 FreeCiv-City FC-Building-University
 cityHasImprovement)
```

That is, the science output of a city (which is a measurable quantity, i.e. one that can be read out of the simulator) can be positively affected by adding an improvement to the city which is a University (i.e. achieving a cityHasImprovement statement relating a city in a Freeciv game with an instance of the concept of university in Freeciv).

To extend narrative functions to handle such type-level influences, we added one new type of narrative function, *IntroductionOfFCRelation*, indicating that new game-relevant information was detected. The new detection rules were of two types. The first extracts a layer of causal relationships from the events found in the linguistic analysis. For example, the sentence above includes two events, one referred to by “adding” and the other referred to by “increases”. Since there is a `doneBy` relationship

produced by the parser that links the two events, the narrative function rules infer a causal relationship between them. That is, the `Incorporation-Physical` event causes the `IncreaseEvent` event. The second type of detection rule looks for causal patterns that suggest an influence at work. For example, if an event causes some statement to be true, and the same event is the causal antecedent of a quantity change event, then that suggests that statement is the condition to use in the type-level influence.

In addition to new narrative function rules, additional statements were made that biased the scoring system for abduction to prefer solutions containing type-level influences and narrative functions. For example, the interpretation of “adding” above to mean the arithmetic operation applied over two numbers did not give rise to causal connections that allowed an influence to be produced, leading the system to automatically prefer physical incorporation as the intended meaning of the word.

Figure 2 depicts a partial dependency structure showing how the influence above was inferred from the analysis of the sentence. The entities and relationships in blue were produced by the parser, while the statements in yellow were produced by the narrative function rules. Notice that the yellow layer consists of very general causal relationships. We suspect that this structure will be very general: The variations in the specifics of language might be handled by rules that produce these general causal relationships, while the more complex narrative functions can be captured by patterns that are truly domain-independent. Whether or not this scales is, of course, an empirical question.

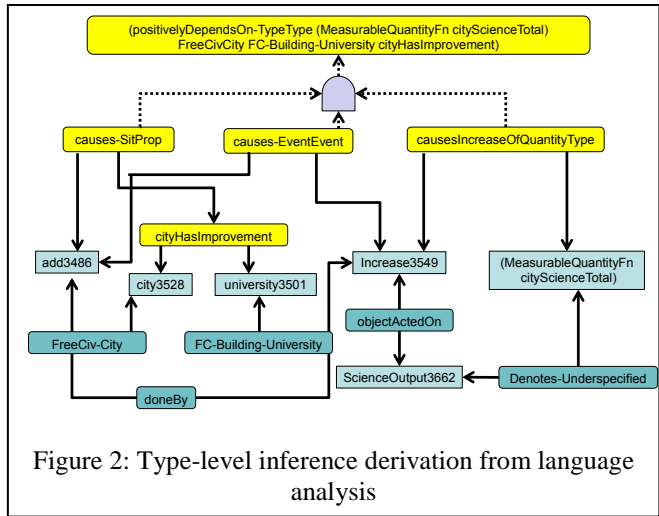

Figure 2: Type-level inference derivation from language analysis

When viewed as advice, is this type of information useful? To find out, we ran a Companion (Forbus et al 2009) with and without the following pieces of advice:

- Adding a granary in a city increases its growth rate.
- Adding a research lab in a city increases its science output.
- Adding a library in a city increases its science output.

² http://freeciv.wikia.com/wiki/Main_Page

- Adding a university in a city increases its science output.
- Irrigating a place increases food production.
- Mining a place increases its shield production.

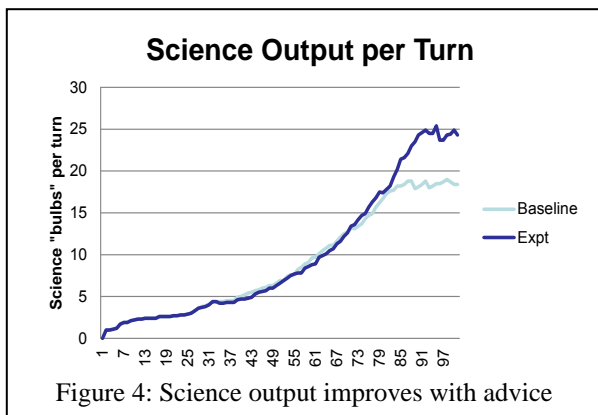
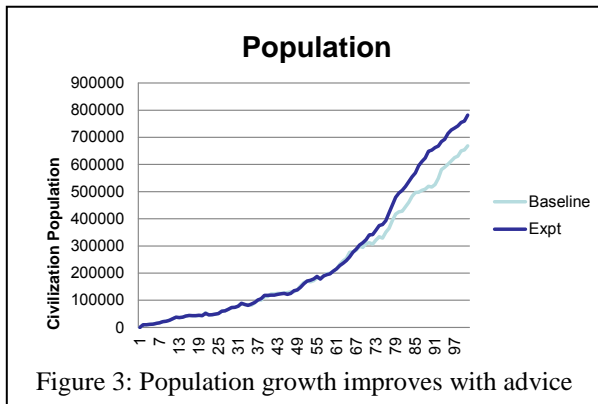

Figures 3 and 4 show the difference in the two conditions, averaged over 10 games. The improvement in population growth (Figure 3) is due to the effect of irrigation, while the improvement in science output (Figure 4) is due to the other improvements. This is encouraging evidence for the utility of type-level influences, expressed via natural language, as a means of giving advice to cognitive systems.

5 Conclusions and Future Work

We have shown evidence that the concept of narrative function can be used to understand texts whose meaning include information expressible via QP theory. It performs almost as well on the original examples of Kuehne (2004), but also can be used to learn advice from language whose meaning can be captured via type-level influences. However, we view these results as preliminary because of limited coverage to date.

We plan to explore several directions in future research, most of them concerned with expanding different aspects of coverage. First, we need to expand the coverage of instance-level qualitative descriptions significantly, to

handle the range of QP-bearing language found in science books. Second, we need to expand the coverage of type-level qualitative descriptions, to handle the descriptions of continuous processes, quantities, and relationships found in both science books and in discussions of planning and strategies involving dynamical systems (for which Freeciv is a useful laboratory). Third, we need to expand the coverage of narrative functions to handle the rest of the material in such texts. Introducing new principles, problem-solving strategies, and examples, for instance, are common types of narrative functions in such texts. Fourth, our current abduction system is limited, in that it does not support backtracking well, nor does it gracefully incorporate evidential reasoning or the use of analogical abduction. We are currently designing a new abduction system that we hope will overcome these limitations.

6 Acknowledgements

This research was sponsored by the Intelligent Systems program of the Office of Naval Research (Grant N00014-07-1-0919), and the Air Force Office of Scientific Research (Award FA2386-10-1-4128).

7 Bibliography

- Allen, J. F. (1994). Natural language understanding (2nd Ed.) Redwood City, CA: Benjamin/Cummings.
- Fillmore, C. J., Wooters, C., & Baker, C. F. (2001). Building a Large Lexical Databank Which Provides Deep Semantics. In Proceedings: Pacific Asian Conference on Language, Information, and Computation, Hong Kong, China.
- Forbus, K. D. (1984). Qualitative Process Theory. *Artificial Intelligence*, 24, 85-168.
- Forbus, K., Klenk, M., and Hinrichs, T. 2009. Companion Cognitive Systems: Design Goals and Lessons Learned So Far. *IEEE Intelligent Systems*, 24(4), 36-46.
- Grishman, R., Macleod, C., & Wolff, S. (1993). *The COMLEX Syntax Project*. Ft. Belvoir: DTIC.
- Hinrichs, T. and Forbus, K. 2012. Learning Qualitative Models by Demonstration. *Proceedings of QR2012*.
- Hobbs, J.R. 2004. Abduction in Natural Language Understanding. In Horn, L. and Ward, G. (eds.), *Handbook of Pragmatics*, pp. 724-741, Blackwell.
- Kamp, H., & Reyle, U. (1993). *From discourse to logic: Introduction to model-theoretic semantics of natural language*. Boston, MA: Kluwer Academic.
- Kuehne, S. E. (2004). Understanding natural language descriptions of physical phenomena. Doctoral dissertation, Northwestern University, Evanston, Illinois.
- Ovchinnikova, E. (2012). Integration of World Knowledge for Natural Language Understanding. Atlantis Press, Springer.
- Tomai, E. (2009). A Pragmatic Approach to Computational Narrative Understanding. Doctoral dissertation, Northwestern University, Department of Electrical Engineering and Computer Science, Evanston, Illinois.
- Tomai, E. and Forbus, K. (2009). EA NLU: Practical Language Understanding for Cognitive Modeling. Proceedings of the 22nd International Florida Artificial Intelligence Research Society Conference. Sanibel Island, Florida.

Towards Cognitive Image Interpretation by Mixing Qualitative Image Descriptions and Feature Object Detectors

Zoe Falomir ^{*}, Lledó Museros, Luis Gonzalez-Abril, Diedrich Wolter, Christian Freksa

Universität Bremen, Universitat Jaume I, Universidad de Sevilla, Universität Bremen, Universität Bremen

Abstract

A new approach to cognitive image interpretation is outlined in this paper. It combines qualitative descriptors with feature detectors for increasing the recognition rate of ‘target’ objects (i.e. objects needed or searched for carrying out a specific task) and also for broadening the capacity of the system which will be able to describe ‘target’ or ‘known’ objects and ‘unknown’ objects by describing its qualitative shape and colour and its spatial situation. This approach also provide the qualitative spatial relations between all the objects in the image which are consistent with the low-level feature detectors. Preliminary tests have been carried out using images taken in two study cases: (i) a robot navigating through the corridors of the TI building at Universitat Jaume I (Spain) and (ii) an ambient intelligent system installed at Cartesium building at Universität Bremen (Germany).

1 Introduction

Companion robots and ambient intelligent systems need to interact with human beings. Those systems usually integrate digital cameras from which they can obtain information about the environment. The ideal systems for interacting with people would be those capable of interpreting their environment (captured by a digital image) cognitively, that is, in a way similar to how people do it. In this way, those systems may align its concepts with human concepts and thus provide common ground for establishing sophisticated communication. However, although many advances have been carried out in computer vision, scene understanding is still an on-going area of research.

In the literature, psychological studies on image description explain that people find the most relevant content and use words (qualitative tags) to describe them [Jørgensen, 1998; Laine-Hernandez and Westman, 2006; Greisdorf and O’Connor, 2002; Wang *et al.*, 2008]. Usually different colours/textures in an image indicate different objects/regions

of interest to people [Palmer, 1999]. Other studies [Freksa, 1991] explain that, although the retinal image of a visual object is a quantitative image in the sense that specific locations on the retina are stimulated by light of a specific spectrum of wavelengths and intensity, the knowledge about this image that can be retrieved from memory is qualitative because people report on what they saw using words and approximate terms. Thus, qualitative representations of images are in many ways similar to the mental images that people report when they attempt to answer questions on the basis of visual memories [Kosslyn *et al.*, 2006].

Because digital images represent visual data numerically, most image processing has been successfully carried out by applying mathematical techniques to obtain and describe image content. Among the most popular developments are feature descriptors and detectors, such as Harris-Affine, Hessian-Affine, MSER, SIFT, SURF, GLOH, etc. (see the work by Mikolajczyk *et al.* [2005] for an overview of all these methods). All these approaches succeeded in obtaining features from digital images for describing and detecting complex real world objects (i.e. textured objects with boundaries difficult to segment and extract). However, these approaches need to produce and store in memory huge numerical descriptions that cannot be interpreted or given a meaning. To establish semantics, features need to be grouped together and linked with cognitive concepts first. The main disadvantage of these feature detectors is that they need a repository of all the possible objects existing in a scenario for identifying them, because they are not able to describe any feature of an object that they have not seen before, that is, that has not been previously stored in memory.

Qualitative approaches for object description in digital images are successful for identifying homogeneous colored objects [Falomir *et al.*, 2013d] but they may be ambiguous when describing textured objects in real world contexts since these approaches use abstractions of features which sometimes may produce too general categorizations. However, some approaches [Falomir, 2011] can use qualitative abstract features: (i) to describe objects which are ‘unknown’ by the system (i.e. not stored in memory, not seen before in a scenario) and (ii) to identify them by matching without any previous training. Qualitative representations have been successfully employed in querying spatial databases [Wallgrün *et al.*, 2010], the main aim here is to analyse if they can enhance

^{*}Correspondence to: Zoe Falomir, Cognitive Systems (CoSy), FB3-Informatik und Matematik, Universität Bremen, Germany. E-mail: zfalomir@informatik.uni-bremen.de

cognitive image/scene descriptions.

The contribution of this paper is an approach for combining qualitative image descriptors with computer vision feature detectors for describing real digital images containing ‘target’ and ‘unknown’ objects taken in real scenarios.

The rest of the paper is organized as follows. In Section 2, the related work in the literature is discussed. In Section 3, the approach for Qualitative Image Description extended with feature detectors (QID+FD) is outlined. Section 4 describes how objects are described qualitatively in the QID approach. Section 5 explains which feature detectors are used for identifying target objects in the images. In Section 6, the cases of study are described and some tests and results are presented. Finally, conclusions and future work are given in Section 8.

2 Related Work

Approaches that extract qualitative/semantic information from images are becoming more frequent in the literature. Socher *et al.* [2000] provided a robotic manipulator system with a verbal description of an image using object recognition methods and limited objects. Oliva and Torralba [2001] used the shape of the Fourier transforms of the images to extract perceptual properties (naturalness, openness, etc.) for classifying them into semantic categories (coast, countryside, mountain, etc.). Lim and Chan [2012] proposed a fuzzy qualitative approach for classifying images of natural scenes which may belong to more than one class (i.e. coast and mountain). Quattoni and Torralba [2009] defined an approach for classifying images of indoor scenes in semantic categories (book store, kitchen, bathroom etc.) using a learning distance for object recognition and training on a dataset. Lovett *et al.* [2006] proposed a qualitative description for sketch image recognition. Qayyum and Cohn [2007] divided landscape images using a grid for identifying semantic categories (grass, water, etc.) and used them for retrieval in data bases. Maillot and Thonnat [2008] described images of pollen grains using an ontology which included features of shape, colour, texture, size and topology. Johnston *et al.* [2008] used an ontology for categorizing the ball and the goal from images captured by an AIBO robot in the Robocup. Neumann and Moller [2008] analysed the use of description logics (DLs) as a knowledge representation and reasoning system for high-level scene interpretation. Schill *et al.* [2009] presented an approach for visual identification and exploration of virtual scenes based on the neurobiological and cognitive principles of human information processing and an OWL ontology combined with a belief theory for adding certainty to the categorization of objects in a virtual world. Falomir *et al.* [2012] defined and generalized an approach for Qualitative Image Description (QID) which applied qualitative models of shape and colour to describe the visual features of all the regions in an image, and qualitative models of topology and orientation to describe their spatial features. The QID was applied to two real-world scenarios: (i) images captured by the webcam of a mobile robot, and (ii) images of tiles captured by an industrial camera used by a robotic arm system to detect tile pieces and assemble tile mosaics.

All the works described above provide evidence for the ef-

fectiveness of using qualitative/semantic information to describe images. The QID-approach [Falomir *et al.*, 2012] showed also a high adaptability to different real-world scenarios and a high flexibility for integration with: (i) description logics [Falomir *et al.*, 2011] and (ii) qualitative distances [Falomir *et al.*, 2013b].

In this paper, the QID-approach is extended for describing and detecting ‘target’ textured objects in real specific scenarios combining qualitative descriptors with computer vision feature detectors and detectors. The main objective is increasing the accuracy when detecting textured ‘target’ objects and also broadening the capacity of the system, which will be able to describe ‘known’/‘target’ objects but also ‘unknown’ objects by describing its qualitative shape and colour and its spatial situation.

3 Describing Real Scenes using Qualitative Descriptors and Feature Detectors (QID+FD)

The QID+FD approach is aimed at describing qualitatively 2D real scenes captured by digital images. For this, the QID+FD approach describes the relevant objects and their spatial arrangement.

The problem of object recognition in real scenes is trivial for human beings but it is still challenging for computer vision because most segmentation techniques are influenced by object textures and illumination conditions and they do not always succeed in extracting real object borders. In order to face this problem, computer vision feature detectors and descriptors (i.e. SIFT, SURF, etc.) have been developed, which can extract features from textured objects and then recognize them. The problem of these feature detectors is that they need a repository of all the possible objects existing in a scenario for identifying them, because they are not able to describe any object that they have not seen before, that is, which has not been previously stored in memory.

The QID+FD approach proposed here (Figure 1) combines the advantage of feature detectors for identifying finite rele-

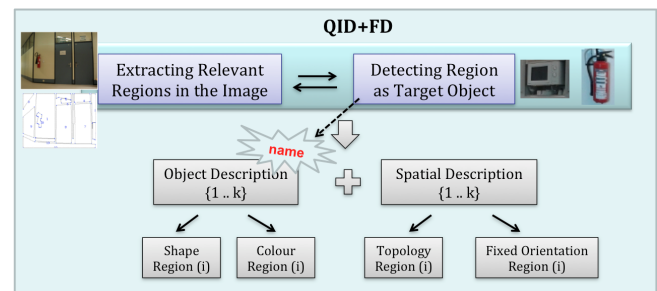

Figure 1: Overview of the QID+FD approach.

vant objects in the scene (i.e. target objects) and the strength of qualitative descriptors which can deal with uncertainty and provide a qualitative description of the shape, colour, topology and orientation of all the objects in a scene, previously seen or not. Moreover, the QID+FD approach can infer what

regions in the image may correspond to some objects of the domain which can be easily identified by its qualitative shape and colour. And also, qualitative descriptors can help feature detectors to discard mismatches of target objects.

4 Qualitative Image Descriptors (QIDs)

The QID approach [Falomir *et al.*, 2012] applies a graph-based region segmentation method [Felzenszwalb and Huttenlocher, 2004] and then extracts the closed boundary of the relevant regions detected within a digital image. Each object/region extracted is described qualitatively by describing its shape (QSD) and its colour (QCD) (Sections 4.1 and 4.2). To build the spatial representation, the object is considered to be positioned in the 2D image space, and its topological description (Section 4.3) and its orientation description (Section 4.4) are provided. Note that topology relations also implicitly describe the relative distance between the objects. Thus, the complete image is described by a set of qualitative descriptions of objects as:

$$[[\text{QDS}_1, \text{QCD}_1, \text{Topology}_1, \text{Orientation}_1], \dots, [\text{QSD}_k, \text{QCD}_k, \text{Orientation}_k, \text{Topology}_k]]$$

where k is the total number of objects.

4.1 Qualitative Shape Description (QSD)

This approach analyses the slope of the pixels within the object boundary and extracts the relevant points of its shape. Each of these relevant points ($\{P_0, P_1, \dots, P_N\}$) is described by a set of four features $\langle \text{EC}_P, \text{A}_P \text{ or } \text{TC}_P, \text{L}_P, \text{C}_P \rangle$, which were defined by Falomir *et al.* [2013a] and are summarized below.

- the Edge Connection (EC) occurring at P , described as: $\{\text{line_line}, \text{line_curve}, \text{curve_line}, \text{curve_curve}, \text{curvature_point}\}$;
- Angle (A) at the relevant point P (which is a *line_line*, *line_curve*, *curve_line*, *curve_curve*) described by the qualitative tags: $\{\text{very_acute}, \text{acute}, \text{right}, \text{obtuse}, \text{very_obtuse}\}$;
- Type of Curvature (TC) at the relevant point P (which is a *curvature_point*) described qualitatively by the tags: $\{\text{very_acute}, \text{acute}, \text{semicircular}, \text{plane}, \text{very_plane}\}$;
- Compared Length (L) of the two edges connected by P , described qualitatively by: $\{\text{much_shorter} (\text{msh}), \text{half_length} (\text{hl}), \text{a_bit_shorter} (\text{absh}), \text{similar_length} (\text{sl}), \text{a_bit_longer} (\text{abl}), \text{double_length} (\text{dl}), \text{much_longer} (\text{ml})\}$;
- Convexity (C) at the relevant point P , described as: $\{\text{convex}, \text{concave}\}$.

Thus, the complete shape of an object is described by a set of qualitative descriptions of relevant points as¹:

$$[[\text{EC}_1, \text{A}_1 \mid \text{TC}_1, \text{L}_1, \text{C}_1], \dots, [\text{EC}_n, \text{A}_n \mid \text{TC}_n, \text{L}_n, \text{C}_n]]$$

where n is the total number of relevant points of the object.

¹ $\text{A}_i \mid \text{TC}_i$ denotes the angle or the type of curvature that occurs at the point P_i .

4.2 Qualitative Colour Description (QCD)

This approach translates the Red, Green and Blue (RGB) colour channels into Hue, Saturation and Lightness (HSL) coordinates, which are suitable for dividing into general intervals of values corresponding to colour names as demonstrated by Falomir *et al.* [2013c].

From the HSL coordinates, a reference system for qualitative colour description is defined as: $\text{QCRS} = \{\text{UH}, \text{US}, \text{UL}, \text{QC}_{\text{LAB}1..5}, \text{QC}_{\text{INT}1..5}\}$ where UH is the Unit of Hue; US is the Unit of Saturation; UL is the Unit of Lightness; $\text{QC}_{\text{LAB}1..5}$ refers to the qualitative labels related to colour; and $\text{QC}_{\text{INT}1..5}$ refers to the intervals of HSL colour coordinates associated with each colour label. The chosen QC_{LAB} and QC_{INT} are:

$$\text{QC}_{\text{LAB}1} = \{\text{black}, \text{dark_grey}, \text{grey}, \text{light_grey}, \text{white}\}$$

$$\text{QC}_{\text{INT}1} = \{[0, 20), [20, 30), [30, 40), [40, 80), [80, 100) \in \text{UH} / \text{US} \in [0, 20]\}$$

$$\text{QC}_{\text{LAB}2} = \{\text{red}, \text{orange}, \text{yellow}, \text{green}, \text{turquoise}, \text{blue}, \text{purple}, \text{pink}\}$$

$$\text{QC}_{\text{INT}2} = \{(335, 360] \wedge [0, 15], (15, 40], (40, 80], (80, 160], (160, 200], (200, 260], (260, 297], (297, 335] \in \text{UH} / \text{US} \in (50, 100] \wedge \text{UL} \in (40, 55]\}$$

$$\text{QC}_{\text{LAB}3} = \{\text{pale}_- + \text{QC}_{\text{LAB}2}\}$$

$$\text{QC}_{\text{INT}3} = \{\forall \text{UH}_{\text{INT}2} / \text{US} \in (20, 50] \wedge \text{UL} \in (40, 55]\}$$

$$\text{QC}_{\text{LAB}4} = \{\text{light}_- + \text{QC}_{\text{LAB}2}\}$$

$$\text{QC}_{\text{INT}4} = \{\forall \text{UH}_{\text{INT}2} / \text{US} \in (50, 100] \wedge \text{UL} \in (55, 100]\}$$

$$\text{QC}_{\text{LAB}5} = \{\text{dark}_- + \text{QC}_{\text{LAB}2}\}$$

$$\text{QC}_{\text{INT}5} = \{\forall \text{UH}_{\text{INT}2} / \text{US} \in (50, 100] \wedge \text{UL} \in (20, 40]\}$$

The QCRS was calibrated according to the vision system used. However, it can be adapted to other vision systems and/or scenarios by defining other colour tags and/or other HSL values.

4.3 Topological Description

In order to represent the topological relationships of the objects in the image, the intersection model defined by Egenhofer and Franzosa [1991] for region configurations in R^2 is used, which describes the topology situation in space (invariant under translation, rotation and scaling) of an object A with respect to (wrt) another object B (A wrt B) as:

$$\text{T}_{\text{LAB}} = \{\text{disjoint}, \text{touching}, \text{completely_inside}, \text{container}\}$$

The T_{LAB} determines if an object is *completely_inside* or if it is the *container* of another object. It also defines the *neighbours* of an object as all the other objects with the same container which can be (i) *disjoint* from the object, if they do not have any edge or vertex in common; (ii) or *touching* the object, if they have at least one vertex or edge in common or if the Euclidean distance between them is smaller than a certain threshold set by experimentation.

4.4 Orientation Description

For representation of orientation information, a sector-based model first proposed by Hernández [1991] is used for obtaining the orientation of an object A with respect to (wrt) its container or the orientation of an object A wrt an object B, neighbour of A. This Image Orientation Reference System (IORS) divides the space into nine regions (see Figure 2).

$$\text{IORS}_{LAB} = \{up, down, left, right, up_left, up_right, down_left, down_right, centre\}$$

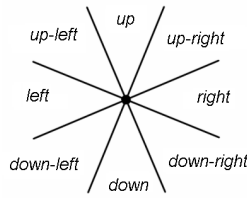

Figure 2: Hernandez's (1991) orientation model for the objects in an image.

In order to obtain the orientation of each object wrt another or wrt the image, this approach locates the centre of the IORS on the centroid of the reference object and its *up* area is fixed to the upper edge of the image. The orientation of an object is determined by the union of all the orientation labels obtained for each of the relevant points of the shape of the object. If an object is located in all the regions of the reference system, it is considered to be in the *centre*.

5 Identifying Target Objects using Feature Detectors

In order to detect a 'target' object in an image, the QID+FD approach uses the Speeded-Up Robust Features (SURF) descriptor and detector defined by Bay *et al.* [2008] which was demonstrated to be the fastest detector in the literature and consists of the following general steps:

1. selecting 'interest points' at distinctive locations in the images, such as corners, blobs, and T-junctions. The most valuable property of an interest point detector is its repeatability (i.e. if it reliably finds the same interest points under different viewing conditions);
2. representing the neighbourhood of every interest point as a feature vector, which has to be distinctive and, at the same time, robust to noise, detection errors, and geometric and photometric deformations;
3. matching the descriptive vectors between different images, which is often based on a distance between the vectors. The matching algorithm selected by the QID+FD approach is the Fast Library for Approximate Nearest Neighbours (FLANN) [Muja and Lowe, 2009].

As Bay *et al.* [2008] mentioned, a balance between the above requirements must be found, like reducing the descriptor dimension and complexity for reducing the execution time, while keeping it sufficiently distinctive.

6 Experimentation and Results

As a proof-of-concept for the QID+FD approach, let us consider the following scenarios (Figure 3). The scenario at Universitat Jaume I where a mobile robot is assigned a 'rescue' task and its 'target' object is a 'fire-extinguisher'. The robot needs scene understanding for detecting the target and explain to a human where it is. The scenario at Universitat

Bremen involves the ambient system *Interact@Cartesium*, a unique setup of *intelligent door tags* (computers) installed in the walls next to every office of the CoSy group which incorporate digital cameras. The system needs scene understanding for monitoring and communicate possible risky situations to researchers.



Figure 3: Scenarios: (a) Pioneer robot at UJI corridors, (b) Cartesium building (the arrows indicate intelligent door tags embedded in the environment).

The QID+FD approach processes the digital images taken at different scenarios as shown in (Figure 4):

- the graph-based region segmentation method by Felzenszwalb and Huttenlocher [2004] is applied and the closed boundary of the relevant regions are extracted. Each object/region extracted is described qualitatively by its shape (QSD), its colour (QCD) and its spatial situation.
- some objects are characterized taking into account the knowledge of the domain and its qualitative shape, colour and its spatial situation. For example: dark blue/grey quadrilateral regions located up and down in the image may be doors at Universitat Jaume I (see Figure 4), while dark blue/grey regions located down in the image may be the floor at Universitat Bremen (see Figure 5).
- the target object in the scenario is determined according to the task to accomplish. Its corresponding features are extracted using the SURF algorithm and their matching locations are found in the scene image using the FLANN algorithm, both taken from the Open Computer Vision Library²(OpenCV) and applied here.
- according to the location of matching features of the target object in the image, the QID+FD approach determines if they are inside an extracted region (applying Jordan's curve theorem [Courant and Robbins, 1996]) and a correspondence between the target object and a region in the QID is determined. Finally, the region corresponding to the target object is identified by the name of the object.

Figure 4 also shows an extract of a qualitative image description (QID) obtained by the QID+FD approach, which can be read as follows. Region 1 is a *pale_yellow quadrilateral*, region 7 is a *dark_grey quadrilateral* and Region 10 is a *dark_red fire-extinguisher*. Regions 1 and 7 were categorized as *UJI-wall* and *UJI-door* (see Falomir *et al.* [2011] for more

²<http://www.opencv.org.cn/opencvdoc/2.3.1/html/>

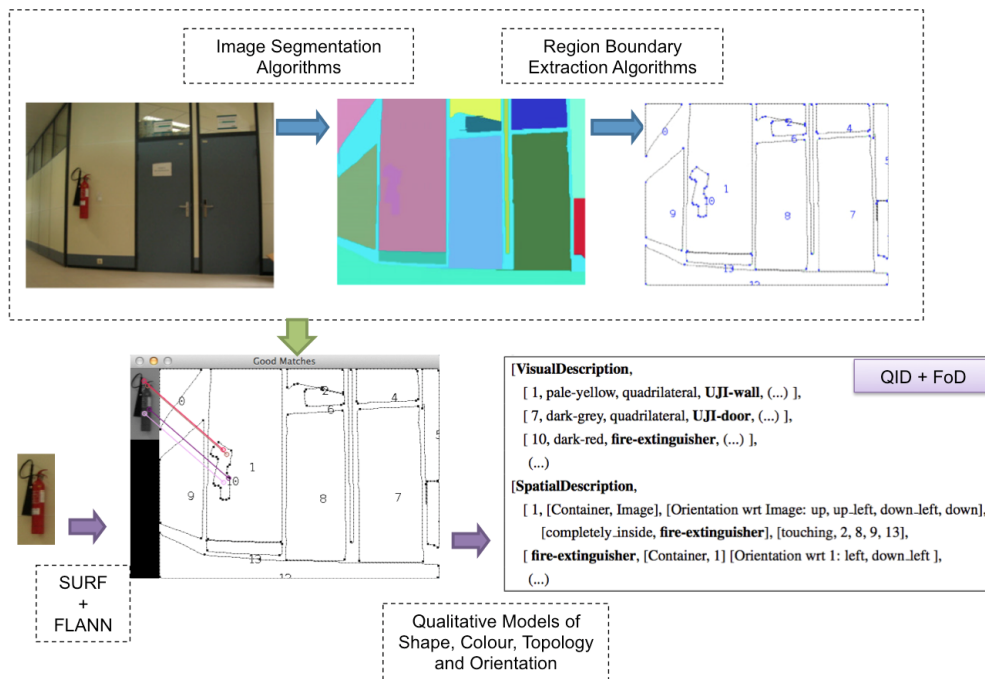

Figure 4: The QID+FD approach using an image taken by a mobile robot in corridor at TI building at Universitat Jaume I (Spain) where the target object is a fire-extinguisher.

details). As spatial descriptions, the QID+FD approach obtains that region 1 is located *up*, *up_left*, *down*, *down_left* wrt to the observer. Its *touching neighbours* are the regions 2, 8 (*UJI-door*), 9, 13. The fire-extinguisher (region 10) is *completely_inside* region 1 (*UJI-wall*) and is located at *left*, *down_left* wrt it.

The QID+FD approach was also tested in some images at *Interact@Cartesium*. Here the task given to the system may be ‘supervising’ electronic machines such as a ‘printer’ or a ‘microwave’ for latter studying its interaction with people at CoSy department. As it is shown in Figure 5, the preliminary tests were successful and the target objects with the corresponding qualitative image descriptions (QIDs) were obtained (the QIDs are not showed here for simplicity). In the scenario at Universitat Bremen, also a fire-extinguisher may be assigned as a ‘target’ to a ‘rescue’ robot. And as Figure 5 (c) shows, a ‘fire-extinguisher’ can be detected in the image with its corresponding QID. Note that this image of the ‘fire-extinguisher’ is different from that provided in Figure 4 because different objects, usually requires different feature detectors.

7 Discussion

Comparing the QID+FD approach to previous works [Falomir *et al.*, 2011] it can be concluded that by incorporating some knowledge of the domain in the system (i.e. pictures of target objects, and broad categorizations of objects) the descriptions obtained are richer.

Besides, the usefulness of qualitative descriptions is remarked again because, in some situations, target objects

have not enough texture features to be detected by feature detectors. Some examples are regions 2 and 3 in Figure 5 (c). Those posters on the walls are not detected by SURF+FLANN in images with 400x300 dimensions. However, its qualitative shape, colour and spatial situation is given and from them, this regions can be categorized as posters.

Moreover, the QID+FD approach offers a qualitative, i.e. symbolic, description that is consistently aligned with a vision system. It can thus provide the important *symbol-grounding* [Williams, 2008] that allows cognitive concepts to be aligned with perception. The advantage of a description based on qualitative tags is also that a semantic meaning can be assigned to them by means of description logics and ontologies. Therefore, the knowledge of any agent able to describe images qualitatively would be increased, i.e. an ambient intelligent agent may ‘be aware’ of the content of the images captured by its cameras, or a mobile robot agent may ‘be aware’ of the object arrangements in the images captured by its webcam. Furthermore, when some objects would be completely unknown to the agents, the qualitative and semantic information extracted could be used to search in the cloud a possible meaning for them (cloud computing, cloud robotics).

Finally, as result of the presented proof-of-concept, further steps are planned for the near future: (i) building an object dataset for further testing and benchmarking different target objects, including their common spatial situations and their affordances, (ii) translating the obtained QIDs to natural language so that they can be more understandable to human beings. Moreover, a new qualitative approach to object descrip-

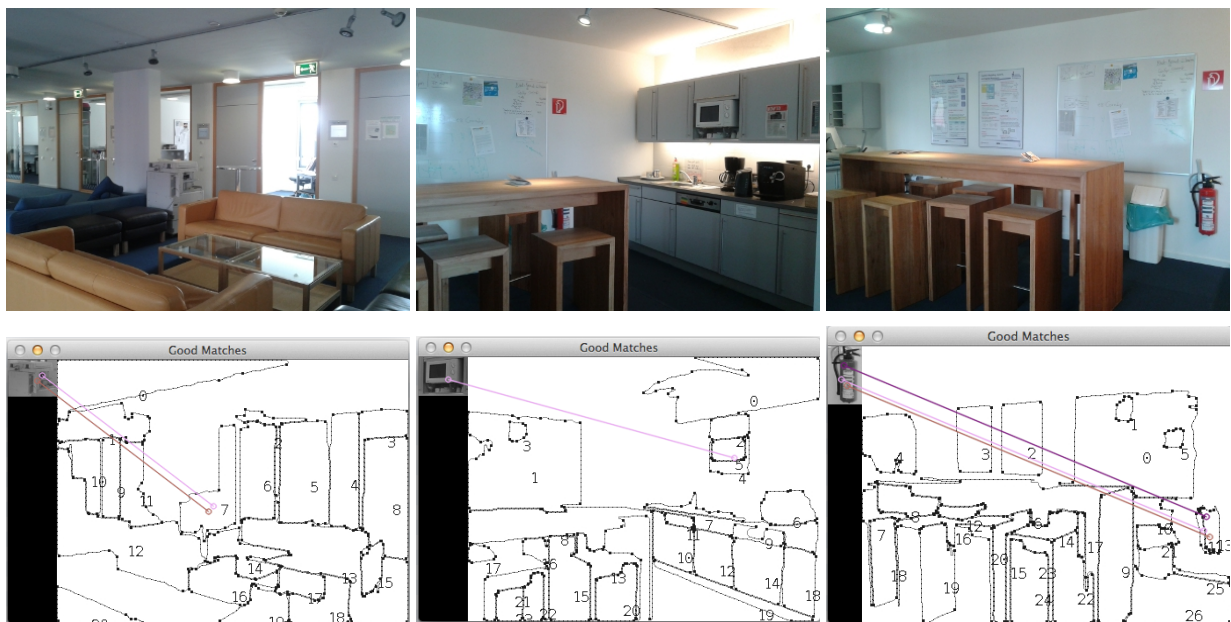

Figure 5: Some results on images taken at the Cartesium building at Universität Bremen (Germany), where the target objects are: a printer, a microwave and a fire-extinguisher.

tion and scene understanding from a 3D perspective is also intended by interpreting the point clouds given as the output of RGB-Depth cameras, such as MS Kinect.

8 Conclusions and Future Work

In this paper, the QID+FC approach is presented which aim is combining qualitative image descriptors with computer vision feature detectors for describing real digital images containing ‘target’ and ‘unknown’ objects and taken in real scenarios.

Preliminary tests of the QID+FD approach are given in two study cases: (i) a robot navigating through the corridors of the TI building at Universitat Jaume I (Spain) and (ii) a ambient intelligent system incorporated at Cartesium building at Universität Bremen (Germany).

Tests carried out using SURF feature object detector and the FLANN matching algorithm showed that the recognition rate for ‘target’ objects (i.e. objects needed or searched for carrying out a specific task) was increased, whereas a qualitative description of some simple objects (without enough texture features) was also needed and useful.

As future work, we intend to: (i) create a repository of target objects for benchmarking; (ii) define a grammar for generating natural language descriptions from the digital images described; and (iii) developing a 3D-QID approach for describing scenes from the output of RGB-Depth cameras, such as MS Kinect.

Acknowledgments

This work has been partially supported by Universität Bremen under the project name “Providing human-understandable qualitative and semantic descriptions”, the

interdisciplinary Transregional Collaborative Research Center Spatial Cognition SFB/TR 8 Project R3-[Q-Shape], the Deutsche Forschungsgemeinschaft (DFG), the Spanish Ministry of Science and Innovation (project ARTEMISA TIN2009-14378-C02-01), the Spanish Ministry of Economy and Competitiveness (project reference TIN2011-24147), Universitat Jaume I-Fundació Bancaixa (P1-1B2010-49) and Departament d’Enginyeria i Ciència dels Computadors at Universitat Jaume I (Fons del Pla Estratègic de 2013).

References

- Herbert Bay, Andreas Ess, Tinne Tuytelaars, and Luc Van Gool. Speeded-up robust features (SURF). *Comput. Vis. Image Underst.*, 110(3):346–359, June 2008.
- Richard Courant and Herbert Robbins. *What Is Mathematics? An Elementary Approach to Ideas and Methods*. Oxford University Press, 1996.
- Max J. Egenhofer and Robert Franzosa. Point-set topological spatial relations. *International Journal of Geographical Information Systems*, 5(2):161–174, 1991.
- Z. Falomir, E. Jiménez-Ruiz, M. T. Escrig, and L. Museros. Describing images using qualitative models and description logics. *Spat. Cogn. Comput.*, 11(1):45–74, 2011.
- Z. Falomir, L. Museros, L. Gonzalez-Abril, M. T. Escrig, and J. A. Ortega. A model for qualitative description of images based on visual and spatial features. *Comput. Vis. Image Underst.*, 116:698–714, 2012.
- Z. Falomir, L. Gonzalez-Abril, L. Museros, and J. Ortega. Measures of similarity between objects from a qualitative shape description. *Spat. Cogn. Comput.*, 13:181–218, 2013.

- Z. Falomir, L. Museros, V. Castelló, and L. Gonzalez-Abril. Qualitative distances and qualitative image descriptions for representing indoor scenes in robotics. *Pattern Recognit. Lett.*, 38:731–743, 2013.
- Z. Falomir, L. Museros, L. Gonzalez-Abril, and I. Sanz. A model for qualitative colour comparison using interval distances. *Displays*, To Appear, 2013. Accepted: 19/07/2013. DOI: 10.1016/j.displa.2013.07.004 (Pre-Print access online).
- Z. Falomir, L. Museros, L. Gonzalez-Abril, and F. Velasco. Measures of similarity between qualitative descriptions of shape, colour and size applied to mosaic assembling. *J. Vis. Commun. Image Represent.*, 24(3):388 – 396, 2013.
- Z. Falomir. *Qualitative Distances and Qualitative Description of Images for Indoor Scene Description and Recognition in Robotics*. PhD thesis, Universitat Jaume I (Spain) and Universität Bremen (Germany), November 2011. <http://www.tdx.cat/handle/10803/52897>.
- P. F. Felzenszwalb and D. P. Huttenlocher. Efficient graph-based image segmentation. *Int. J. Comput. Vis.*, 59(2):167–181, 2004.
- C. Freksa. Qualitative spatial reasoning. In D. M. Mark and A. U. Frank, editors, *Cognitive and Linguistic Aspects of Geographic Space*, NATO Advanced Studies Institute, pages 361–372. Kluwer, Dordrecht, 1991.
- H. Greisdorf and Brian O’Connor. Modelling what users see when they look at images: a cognitive viewpoint. *Journal of Documentation*, 58(1):6–29, 2002.
- D. Hernández. Relative representation of spatial knowledge: The 2-D case. In David M. Mark and Andrew U. Frank, editors, *Cognitive and Linguistic Aspects of Geographic Space*, NATO Advanced Studies Institute, pages 373–385. Kluwer, Dordrecht, 1991.
- B. Johnston, F. Yang, R. Mendoza, X. Chen, and M.-A. Williams. Ontology based object categorization for robots. In *PAKM ’08: Proc. 7th Int. Conf. on Practical Aspects of Knowledge Management*, volume 5345 of *LNCS*, pages 219–231, Berlin, Heidelberg, 2008. Springer-Verlag.
- C. Jörgensen. Attributes of images in describing tasks. *Information Processing Management: an International Journal*, 34(2-3):161–174, 1998.
- S. M. Kosslyn, W. L. Thompson, and G. Ganis. *The Case for Mental Imagery*. Oxford University Press, New York, USA, 2006.
- M. Laine-Hernandez and S. Westman. Image semantics in the description and categorization of journalistic photographs. In A. Grove and J. Steff-Mabry, editors, *Proc. 69th Annual Meeting of the American Society for Information Science and Technology*, volume 43, pages 1–25, 2006.
- C. H. Lim and C. S. Chan. A fuzzy qualitative approach for scene classification. In *Proc. IEEE Int. Conf. on Fuzzy Systems, Brisbane, Australia, June 10-15, 2012*, pages 1–8, 2012.
- A. Lovett, M. Dehghani, and K. Forbus. Learning of qualitative descriptions for sketch recognition. In *Proc. 20th Int. Workshop on Qualitative Reasoning (QR), Hannover, New Hampshire, USA, July 10-12, 2006*.
- Nicolas Maillot and Monique Thonnat. Ontology based complex object recognition. *Image Vision Comput.*, 26(1):102–113, 2008.
- K. Mikolajczyk, T. Tuytelaars, C. Schmid, A. Zisserman, J. Matas, F. Schaffalitzky, T. Kadir, and L. Gool. A comparison of affine region detectors. *Int. J. Comput. Vis.*, 65(2):43–72, 2005.
- M. Muja and D. Lowe. Fast approximate nearest neighbors with automatic algorithm configuration. In *In VISAPP International Conference on Computer Vision Theory and Applications*, pages 331–340, 2009.
- B. Neumann and R. Moller. On scene interpretation with description logics. *Image Vision Comput.*, 26(1):82–101, January 2008.
- A. Oliva and A. Torralba. Modeling the shape of the scene: A holistic representation of the spatial envelope. *Int. J. Comput. Vision*, 42(3):145–175, 2001.
- S. Palmer. *Vision Science: Photons to Phenomenology*. MIT Press, 1999.
- Z. U. Qayyum and A. G. Cohn. Image retrieval through qualitative representations over semantic features. In *Proc. 18th British Machine Vision Conf, Warwick, UK*, pages 610–619, 2007.
- A. Quattoni and A. Torralba. Recognizing indoor scenes. In *IEEE Computer Society Conference on Computer Vision and Pattern Recognition*, volume 0, pages 413–420, Los Alamitos, CA, USA, 2009. IEEE Computer Society.
- K. Schill, C. Zetsche, and J. Hois. A belief-based architecture for scene analysis: From sensorimotor features to knowledge and ontology. *Fuzzy Sets Syst.*, 160(10):1507–1516, 2009.
- G. Socher, G. Sagerer, and P. Perona. Bayesian reasoning on qualitative descriptions from images and speech. *Image and Vision Computing*, 18(2):155–172, 2000.
- J. O. Wallgrün, D. Wolter, and K.-F. Richter. Qualitative matching of spatial information. In *Proc. 18th SIGSPATIAL Int. Conf. on Advances in Geographic Information Systems*, pages 300–309, New York, USA, 2010. ACM.
- X. Wang, P. Matsakis, L. Trick, B. Nonnecke, and M. Velzman. A study on how humans describe relative positions of image objects. In *Lecture Notes in Geoinformation and Cartography, Headway in Spatial Data Handling*, pages 1–18. ISBN: 978-3-540-68565-4, Springer, Berlin Heidelberg, 2008.
- M.-A. Williams. Representation = grounded information. In *PRICAI ’08: Proc. 10th Pacific Rim Int. Conf. on Artificial Intelligence*, volume 5351 of *LNCS*, pages 473–484, Berlin, 2008. Springer-Verlag.

Traffic sign recognition with qualitative theories

Lledó Museros¹, Zoe Falomir², Ismael Sanz¹, Luis Gonzalez-Abril³

¹Universitat Jaume I; ²Bremen University; ³Universidad de Sevilla

Abstract

In this paper a novel approach for traffic sign representation and classification is presented. Its intention is to demonstrate that qualitative theories for shape, color and orientation can be used for traffic sign recognition. This system can be applied to color images, and it has been tested with real sign images showing a recognition rate up to 91%.

1 Introduction

For car drivers, correctly identifying traffic signs at the right time and place plays a crucial part in ensuring their, and their passengers' safety. Sometimes, due to changing weather conditions or viewing angles, traffic signs are not easily seen until it is too late. Development of automatic systems for recognition of traffic signs is therefore an important approach to improve driving safety [Handman et al. 2000; Hsien 2003; Liu et al. 2002; Yen et al. 2004]. For traffic sign recognition, feature representations should be robust and invariant with respect to possible transformations of shapes and change of colors as happened in a driving situation. Therefore it seems that qualitative descriptions can be useful for this task, and this paper tries to demonstrate this statement.

In the process for the recognition of traffic signs, it is first necessary to have a method to detect the sign within an image, and then the sign description and classification is done. In this paper a method for sign description and recognition is presented, and sign detection can be done with any method previously developed in other approaches [Hibi 1996; Miura et al. 2000; Fang 2003; Viola 2004; Barnes et al. 2004; Loy and Barnes 2004; Perez and Javidi 2002]. Therefore, the approach here described is applied once the sign has been detected.

Most of the approaches in this field have employed neural networks [Escalera et al. 2003; Kanda et al. 2000; Hsu and Huang 2001] or support vector machines (SVM) [Gil-Jiménez et al. 2007] for the recognition of traffic signs. However, this paper does not develop a neural network or a SVM. Instead, signs are classified only in function of a similarity measure between the sign to classify and the set of all the possible signs defined and described offline prior

to the beginning of the experiment. Using only a similarity calculus this approach gets up to a 91% recognition rate.

Qualitative models for shape description and approximate matching have been successful applied in object similarity calculus [Falomir et al. 2013a] and also in mosaic assembling combined with qualitative models for color description [Falomir et al. 2013b]. Here these approaches are extended to consider the inner figures of the objects and their orientation.

The initial set of images considered in this paper is shown in Fig. 1. The set of images have been divided into four categories: warning, danger, prohibition and priority.



Fig. 1 Set of images considered.

The system here presented, given a digital image with a single traffic sign, first applies an image segmentation method as explained in [Falomir et al. 2012], and then the next information is automatically extracted: the shape and color of the exterior border of the sign, its interior color, and the shape and color of each figure inside the sign. Using this information, each sign will be described and then classified. Each sign is described by using a Qualitative Shape Description (QSD) theory, which is presented in section 2. The colors in each sign are also described qualitatively using a Qualitative Color Description (QCD) theory presented in section 3. Section 4 describes how the orientation of the figures inside a sign is qualitatively described with a Qualitative Orientation Description (QOD) theory. Section 5 describes how the similarity of each feature is calculated. The experiment developed and the results are discussed in sections 6 and section 7 respectively. Finally, Section 8 gives some conclusions and ideas for future work.

2 The model for Qualitative Shape Description (QSD)

The approach is based on segmenting an image and automatically extracting the boundary of any object contained within it. Then, the relevant points that characterize the shape of the object (mainly vertices and points of curvature) are obtained by analyzing the slope, defined by groups of points contained in the boundary. Finally, each relevant point (P) is described by a set of features $\langle \text{KEC}_p, A_p \text{ or } \text{TC}_p, L_p, C_p \rangle$, defined as:

- Kind of Edges Connected (KEC) by the relevant point P , described as $\{\text{line_line}, \text{line_curve}, \text{curve_line}, \text{curve_curve}, \text{curvature_point}\}$;
- Angle (A) at the relevant point P , described as $\{\text{very_acute}, \text{acute}, \text{right}, \text{obtuse}, \text{very_obtuse}\}$;
- Type of Curvature (TC) at the relevant point P , described as $\{\text{very_acute}, \text{acute}, \text{semicircular}, \text{plane}, \text{very_plane}\}$;
- Compared Length (L) of the two edges connected by P , described as $\{\text{much_shorter} (\text{msh}), \text{half_length} (\text{hl}), \text{a_bit_shorter} (\text{absh}), \text{similar_length} (\text{sl}), \text{a_bit_longer} (\text{abl}), \text{double_length} (\text{dl}), \text{much_longer} (\text{ml})\}$;
- Convexity (C) at the relevant point P , described as $\{\text{convex}, \text{concave}\}$.

Fig. 2 presents the qualitative shape description of a traffic sign. In the QSD description the first described vertex is always the upper-leftmost one, which in the case of the sign in Fig. 2 is the upper one.

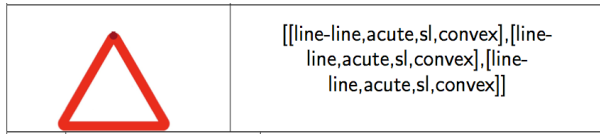

Fig. 2. QSD of a traffic sign.

3 The model for Qualitative Color Description (QCD)

This approach is based on the standard Red, Green and Blue color channels (sRGB) of the predominant color of the object (the mean of the sRGB color channels of all the pixels of the image), which are translated into coordinates of Hue, Saturation and Lightness (HSL) color space in order to give a name to the color of the objects.

From the HSL color coordinates obtained, a reference system for qualitative color naming is defined as $QCRS = \{UH, US, UL, QC_{LAB1..5}, QC_{INT1..5}\}$ where UH is the Unit of Hue; US is the Unit of Saturation; UL is the Unit of Lightness; $QC_{LAB1..5}$ refers to the color names; and $QC_{INT1..5}$ refers to the intervals of HSL color coordinates associated with each

color name. In our application, the QC_{LAB} and QC_{INT} are the following:

$$\begin{aligned} QC_{LAB1} &= \{\text{black} (bk), \text{dark_grey} (dg), \text{grey} (g), \\ &\text{light_grey} (lg), \text{white} (w)\} \\ QC_{LAB2} &= \{\text{red} (r), \text{yellow} (y), \text{green} (gn), \text{turquoise} (t), \\ &\text{blue} (b), \text{purple} (pu), \text{pink} (pk)\} \\ QC_{LAB3} &= \{\text{pale_} + QC_{LAB2}\} \\ QC_{LAB4} &= \{\text{light_} + QC_{LAB2}\} \\ QC_{LAB5} &= \{\text{dark_} + QC_{LAB2}\} \end{aligned}$$

The US coordinate of the HSL color space determines if the color corresponds to the grey scale or to the rainbow scale: QC_{LAB1} and QC_{LAB2} , respectively. This coordinate also determines the intensity of the color (pale or strong). The colors in the rainbow scale are considered as the strong ones, while the pale colors are given an explicit name in QC_{LAB3} . The UH coordinate determines the division into color names inside each scale. This value is circular, for example, both $0\ uh$ and $360\ uh$ represent the color red. Finally, the UL coordinate determines the luminosity of the color: dark and light colors are given an explicit name in QC_{LAB4} and QC_{LAB5} , respectively. The intervals of HSL values which define the color names ($QC_{INT1..5}$) have been calibrated to the images to be described, in this case the traffic sign images. And, for example, the colors names given to the sign in Fig. 2 is *red* for the boundary and *white* for the interior.

4 The model for Qualitative Orientation Description (QOD)

Taking into account the orientation is necessary in this approach in order to relate the figures that can appear inside a traffic sign. In order to define the orientation of a figure A with respect to (wrt) a figure B , the centroids of both figures, named $a(x,y)$ and $b(x,y)$ respectively, are considered. Then, two orientation tags are established: the first one is defined in order to define the horizontal orientation relation of $A\ wrt\ B$ as follows:

$$\begin{aligned} &\text{If } b.x < a.x \pm t_1 \text{ then "left"} \\ &\text{Else if } b.x = a.x \pm t_1 \text{ then "equal"} \\ &\text{Else "right"} \end{aligned}$$

Analogously the other orientation tag is also defined. It is defined in order to define the vertical orientation relation of $A\ wrt\ B$:

$$\begin{aligned} &\text{If } b.y < a.y \pm t_2 \text{ then "up"} \\ &\text{Else if } b.y = a.y \pm t_2 \text{ then "equal"} \\ &\text{Else "down"} \end{aligned}$$

In the above algorithms, the symbols t_1 and t_2 represent the thresholds used to compare the coordinates. It is necessary to define these thresholds because it is very difficult to find two centroids perfectly aligned with the exact x , and y coord-

dinates. The thresholds have to be established experimentally according to the image size.

5 Shape, Color, and Orientation Similarity Calculus

The approach to obtain dissimilarity values between qualitative parameters of shape, between qualitative colors and between qualitative orientation is based on Conceptual Neighborhood Diagrams (CNDs).

Freksa [1991] determined that two qualitative terms are conceptual neighbors if “one can be directly transformed into another by continuous deformation”. Therefore, acute and right angles are conceptual neighbors since an extension of the angle acute causes a direct transition to the right angle. CNDs can be described as graphs containing: (i) nodes that map to a set of individual relations defined on intervals and (ii) paths connecting pairs of adjacent nodes that represent the continuous transformations which can have weights assigned in order to establish priorities. For each of the features in our models for QSD and QCD, a CND has been defined by Falomir et al. [2010]. Then, dissimilarity matrices are constructed to map the pairs of nodes in each CND to the minimal path distance between them.

As the qualitative shape of an object is described by means of all its relevant points (RPs), in order to define a similarity measure between shapes, first a similarity between relevant points has to be obtained. Hence, given two relevant points, denoted by RP_A and RP_B , belonging to the shapes of the objects A and B respectively, a similarity between them, denoted by $SimRP(RP_A, RP_B)$, is defined as:

$$SimRP(RP_A, RP_B) = 1 - \sum_{i \in \{KEC, ATC, L, C\}} w_i \frac{dsShape(i)}{DsShape(i)} \quad (1)$$

where $dsShape(i)$ denotes the dissimilarity between RP_A and RP_B with respect to feature i , obtained from the dissimilarity matrices constructed. $DsShape(i)$ denotes the maximum dissimilarity in the dissimilarity matrix related to the feature i . Hence, by dividing $dsShape(i)$ and $DsShape(i)$ the proportion of dissimilarity between RP_A and RP_B related to feature i is obtained, which is between 0 and 1. The parameter w_i is the weight assigned to feature i , and it holds that $w_{KEC} + w_{ATC} + w_L + w_C = 1$ and $w_i \geq 0$. In our scenario, $w_{KEC} = w_{ATC} = w_L = w_C = 0.25$. The final value is subtracted from 1 in order to provide a similarity between relevant points, instead of a dissimilarity.

In order to compare two shapes A and B , with n and m relevant points, the similarity between A and B ($SimQSD(A, B)$) is calculated from (1) as an arithmetic mean of the similarity between relevant points of both shapes in a clockwise direction. If $n \geq m$, then there are some relevant points of A with no corresponding points in B . In this case, the points with no corresponding pairs are compared to the *void* relevant point

and the similarity between both points is zero. Therefore the similarity between A and B is:

$$SimQSD(A, B) = \frac{1}{n} \sum_{\substack{RP_A \in A \\ RP_B \in B}} SimRP(RP_A, RP_B) \quad (2)$$

With respect to the color similarity calculus, let QC_A and QC_B be the colors of objects A and B respectively, then a similarity between them, denoted by $SimQCD(QC_A, QC_B)$, is defined in function of their conceptual neighborhood as follows: 1 if both colors have the same qualitative label, 0.95 if the colors of A and B have a conceptual neighborhood distance of 1, 0.9 if they have a conceptual neighborhood distance of 2, and 0 otherwise. For instance the *red* has a distance of 1 with *red*, of 0.95 with *yellow* and *pink*, of 0.9 with *green* and *purple*, and 0 with the rest of colors. All the above values have been established experimentally.

With respect to the orientation similarity calculus, a CND for each orientation tag is also defined, and shown in Fig. 3.

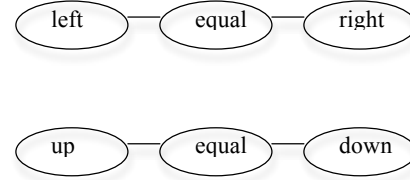

Fig. 3. CNDs for the QOD model

Given the above CNDs, $SimQOD(QC_A, QC_B)$ is obtained by the similarity matrices shown in Table 1 and 2. Also the values in the matrices have been established experimentally.

	Left	Equal	Right
Left	1	0.95	0
Equal	0.95	1	0.95
Right	0	0.95	1

Table 1. Qualitative similarity matrix for the horizontal qualitative orientation.

	Up	Equal	Down
Up	1	0.95	0
Equal	0.95	1	0.95
Down	0	0.95	1

Table 2. Qualitative similarity matrix for the vertical qualitative orientation.

6 Traffic sign description and recognition

In the system developed for traffic sign classification, first each traffic sign of the database (signs shown in Fig. 1) is described as shown in the example of Fig. 4. For each sign, the qualitative shape description of the boundary is obtained, including also its number of vertices and its color. Then, the background color of the traffic sign is also stored

qualitatively. If the traffic sign has figures inside, then the boundary, number of vertices, and qualitative color of each figure are calculated. If there is more than one figure inside the traffic sign, the qualitative horizontal and vertical orientations of the figures are also calculated.

Then, when a new image of a traffic sign is introduced to the system, in order to determine which specific sign it is, it has to be described following also the same scheme.

With the description of all the images of the database and the description of the image to classify (*target sign*) the recognition process starts by calculating the similarity of the exterior information of the *target sign* wrt the ones in the database. Using only this similarity the system determines the type of the sign to recognize (warning, danger, prohibition and priority). The exterior similarity (*SimEx*) is calculated as follows:

$$SimEx(QC_A, QC_B) = 0.3 * SimBoundCol(QC_A, QC_B) + 0.2 * SimBackGrCol(QC_A, QC_B) + 0.5 * SimBoundShape(QC_A, QC_B);$$

where *SimBoundCol* is the similarity between the boundary colors of both traffic signs, and *SimBackGrCol* is the similarity between their background colors. Both similarities are calculated as described in previous section. *SimBoundShape* is the similarity between the boundary shapes of the images, also calculated as described in section 5. The weights (0.3, 0.2, and 0.5) have been established experimentally to account for the importance of each feature for the traffic sign classification.





Graphic Representation				
Interpretation	Warning: One way traffic, two lane road			
Boundary	QSD	N. Vertices	Boundary C.	Bac kgr. C.
	[[line-line,right,sl,convex],[line-line,right,sl,convex],[line-line,right,sl,convex],[line-line,right,sl,convex]]	4	White	Blue
N°	QSD	C	N V	O.
1		White	7	
2		White	7	equal and right wrt 1

Fig. 4. Example of the description of a traffic sign image.

SimEx is calculated for the target sign with respect to all the types of traffic signs our database. Then, the type of the target sign is determined by choosing the types that have the maximum (it can be one maximum or more) value of *SimEx*. Once the type or types are determined, the final classification step starts in which the specific traffic sign that corresponds to the target sign is specified.

In the last step, for each type selected, the target sign is compared with all the traffic signs inside the determined type by calculating also a similarity. The similarity is calculated in different ways depending of the number of inner figures, and a traffic sign is only compared with other ones with the same number of inner figures. If the signs have no inner figures the similarity between the signs is calculated as *SimEx* (*SimIn* = *SimEx*). If they have only one inner figure the similarity is calculated as:

$$SimIn(QC_A, QC_B) = 0.5 * SimColor(QC_A, QC_B) + 0.5 * SimShape(QC_A, QC_B);$$

where *SimColor* is the color similarity between the color of both inner figures, and *SimShape* their shape similarity, both calculated as in section 5.

If the traffic signs have more than one inner figure, then the similarity is calculated as:

$$SimIn(QC_A, QC_B) = (\sum_{i=1..N} [0.15 * SimVerticalOrient(QC_A, QC_B) + 0.15 * SimHorizontalOrient(QC_A, QC_B) + 0.4 * SimColor(QC_A, QC_B) + 0.3 * SimShape(QC_A, QC_B)]) / N;$$

where *SimVerticalOrient* and *SimHorizontalOrient* are the similarity between the qualitative vertical orientation and the qualitative horizontal orientation respectively of both inner figures, and N is the number of inner figures. Again the weights (0.15, 0.3, and 0.4) have been established experimentally to account for the importance of each feature for the traffic sign classification.

Then, the final similarity between two traffic signs is calculated as:

$$SimFinal(QC_A, QC_B) = (0.5 * SimEx(QC_A, QC_B) + 0.5 * SimIn(QC_A, QC_B)) / 2$$

Therefore, the target sign will be classified as the specific sign with which it has a bigger *SimFinal*. If several maximums were obtained, then the sign would be classified as all the signs with the maximum *SimFinal*.

7 Experimentation and results

In order to test the approach presented, the images of the database were digitally created using an image editor (Photoshop Elements), and the images to classify were obtained from photographs taken with a digital camera (Sony DSC-W290). From each photograph, only the sign was extracted and described. Fig. 5 shows an example of one photographed traffic sign, that was correctly classified

as a “Warning: One-way traffic, two lane road” sign with a 97.19% of similarity.



Fig 5. a) Traffic sign photograph; b) its equivalent image in the database

Table 3 shows several real images, their classification result and the similarity obtained with the presented method. This table shows also that similar traffic signs have been also successfully classified (as it is shown in the 3rd, 4th and 5th rows).

The experiments were carried out on a Dell XPS m1330 portable computer, with a M1330 CORE 2 DUO T9500 2.60GHZ CPU.

With a set of more than 50 photographs to classify, the system has obtained a recognition rate of 87% with a temporal cost of 77.64 milliseconds as average for the classification of a traffic sign.

The recognition rate of traffic signs that have not curvilinear segments is higher, 91%, because the segmentation process followed to obtain the curvature information has to be improved in order to get better recognition rates.

	Junction with a minor side-road right	98.75%
	Junction with a minor side-road left	99%
	Start of a third lane	96.25%
	Give way over oncoming traffic	85.81%

Table 3. Example of photographs successfully classified

Target sign	Classified as	Final Similarity
	Parking area	88.63%
	Crossroads with right-of-way from the right	97%
	Crossroads ahead	99%

Fig. 6 shows an example of a traffic sign that has not been successfully classified. It represents a false positive. This sign is a “humps” sign but it has been classified as a “Left Priority Intersection” with a similarity measure of 92.81%. The reason is that the inner figure has not been correctly described because of its curvature elements.



Fig. 6. Photograph of a traffic sign that has been classified incorrectly.

The images shown in Table 3 also demonstrate that the traffic signs in the photograph have noise associated (different shapes due to e.g. the angle of the picture, or color differences,) and the use of the qualitative method here described has been able to manage this problem.

Although the image database used in this experimentation is small and may not indicate the correct performance of the proposed method in more realistic settings, it shows the ability of qualitative theories to deal with the problem of traffic sign recognition. The comparison (Table 4) of the initial results presented in this paper with previous work

demonstrates that they are promising enough to continue research in this field.

Method	Recognition Rate
Legendre moments	97.5%
Invariant features	94.5%
Fuzzy sets and shape measures	88.4%
Eigenvector based	96.8%
Color distance	93.5%
Our method	91%

Table 4. Comparison of the presented method with other methods in the literature.

The work in [Fleyeh and Dougherty 2007] has a recognition accuracy of 97.5% using Legendre moments of the tenth order and a SVM classifier. A recognition rate of 88.4% is reported by using shape measures and fuzzy sets [Fleyeh 2008], 94.5% by using invariant features [Fleyeh and Dougherty 2008], 96.8% by using eigenvectors and a principal component analysis algorithm [Fleyeh and Davami 2010], and 93.5% by using a color distance transform representation and a feature selection algorithm [Ruta et al. 2007]. The recognition is achieved in 0.013, 0.15, 0.09, 0.001, and 0.8 seconds respectively.

Our work can be classified as a shape measures-based method, and the recognition rate is competitive with that obtained by other methods of the same kind.

An important point is that a good traffic sign recognition system has to be able to recognize signs that are rotated and/or partially occluded. For instance, the recognition rate of [Fleyeh and Davami 2010] decreases to 89% for the recognition of traffic signs rotated 10 degrees around their centre, and to 71% is the signs are partially occluded. An advantage of the presented method is that it is invariant to small rotations, and the recognition rate does not decrease with images rotated slightly with respect to the pattern sign. As future work, the approach will be extended and tested with partially occluded signs.

Finally, it is usual that traffic sign recognition methods, such as the presented method, get different rates in function of the type of segments of the figures (straight-lines or circular lines). For instance, [Hsu and Huang 2001] show that they obtain a recognition rate of 94% for triangular road signs and of 91% of circular road signs, [Brkic 2010] gets a rate of 79.4% for circular signs with red rim and a 97.3% for blue circular signs, and [Ruta et al. 2007] obtain a rate of 100% for red and blue circles, 88.7% for yellow triangles and of 91.2% for blue squares.

8 Conclusions and future work

This paper has demonstrated that it is possible to use qualitative theories of shape, color and orientation descriptions for traffic sign description and classification. The approach presented is also able to manage the noise associated to a real digital image of a traffic sign.

For the traffic sign recognition only a similarity measure is defined based on conceptual neighborhoods, which does not need training. As future work it would be useful to use this

similarity as part of a learning process using neural networks or SVMs and test whether the recognition rate is improved.

If the sign has curvilinear segments, the recognition is more difficult because the segmentation process used does not obtain the curvature information correctly. Therefore, another improvement would be to develop a new method to extract curvilinear information or to approximate the curves to small straight segments.

Also, the system has to be extended in order to recognize all legally defined traffic signs to and test if the recognition rate is still the same.

Finally, using a qualitative method to describe and classify traffic signs allows the gathering of semantic information from the signs. Therefore, using the approach here described makes it possible to develop a learning system to support the teaching of traffic signs.

Acknowledgments

This work has been partially funded by the “Ministerio de Economía y Competitividad” with contract number TIN2011-24147, the Fundació Caixa Castelló project P1-1B2010-49, by the Spanish Ministry of Science and Innovation R&D project ARTEMISA (TIN2009-14378-C02-01), by Universität Bremen under project name “Providing human-understandable qualitative and semantic descriptions”, the interdisciplinary Transregional Collaborative Research on Spatial Cognition SFB/TR 8 Project R3-[Q-Shape], the Deutsche Forschungsgemeinschaft (DFG), and the Department of Computer Science and Engineering of Universitat Jaume I.

References

- N. Barnes and A. Zelinsky. Real-time radial symmetry for speed sign detection. *Proc. IEEE Intell. Veh. Symp.*, page 566-571, 2004.
- K. Brkic, “An overview of traffic sign detection methods”. Department of Electronics, Microelectronics, Computer and Intelligent Systems Faculty of Electrical Engineering and Computing Croatia, Tech. Report, 2010.
- A. de la Escalera, J.M. Armingol, M. Mata, Traffic sign recognition and analysis for intelligent vehicles *Image and Vision Computing 21*, pp. 247-258, 2003
- C.Y. Fang, S.W. Chen, and C.S. Fuh, Road-Sign Detection and Tracking, *IEEE Transactions on Vehicular Technology*, vol. 52, no. 5, pp. 1329-1341, 2003
- Z. Falomir, I. Martí, W. Viana, L. Museros, M. T. Escrig, A Pragmatic Approach for Qualitative Shape and Qualitative Colour Similarity Matching. In René Alquézar, Antonio Moreno and Josep Aguilar (Eds.), *Artificial Intelligence Research and Development, Frontiers in Artificial Intelligence and Applications, IOS Press, Vol. 220*, pp. 281-290, 2010.
- Z. Falomir, Ll. Museros, Lledó, L. Gonzalez-Abril, M.T. Escrig, J.A. Ortega, A model for the qualitative description of images based on visual and spatial features. *Computer Vision and Image Understanding vol. 116 issue 6* pp. 698-714, 2012.

- H. Fleyeh Traffic Sign Recognition by Fuzzy Sets. *IEEE Intelligent Vehicles Symp*, pp. 422-427, 2008.
- H. Fleyeh, and E. Davami, Eigen-based traffic sign recognition, *IET Intelligent Transport Systems, Vol. 5, Issue 3*, pp. 190-196, 2011.
- H. Fleyeh, and M. Dougherty, SVM based traffic sign classification using legendre moments, In proc. of the *Third Indian Int. Conf. on Artificial Intelligence*, India, 2007.
- H. Fleyeh, and M. Dougherty, Traffic sign classification using invariant features and support vector machines, *IEEE Intelligent Vehicles Symp*, pp. 530-535, 2008.
- C. Freksa, Conceptual neighbourhood and its role in temporal and spatial reasoning, In Singh, M., Trave-Massuyes, L. (eds.) *Decision Support Systems and Qualitative Reasoning*, pp. 181-187, 1991.
- P. Gil-Jiménez, H. Gómez-Moreno, F. López-Ferreras, S. Maldonado-Bascón, and S. Lafuente-Arroyo. Road-sign detection and recognition based on support vector machines. *IEEE Transactions On Intelligent Transportation Systems, Vol. 8, No. 2*, pp. 264-278, 2007
- U. Handmann, T. Kalinke, C. Tzomakas, M. Werner, A image processing system for driver assistance, *Image and Vision Computing 18 (5)*, pp. 367-376, 2000
- T. Hibi, Vision based extraction and recognition of road sign region from natural colour image, by using HSL and coordinates transformation, *29th International Symposium on Automotive Technology and Automation, Robotics, Motion and Machine Vision in the Automotive Industries*, ISATA, 1996.
- J.C. Hsien, and S.Y. Chen, Road Sign Detection and Recognition Using Markov Model. *14th Workshop on OOTA*, pp. 529-536, 2003
- S. H. Hsu and C. L. Huang. Road sign detection and recognition using matching pursuit method. *Image Vis. Comput., vol. 19*, pp. 119-129, 2001.
- T. Kanda J. Miura and Y. Shirai. An active vision system for real-time traffic sign recognition. *IEEE Intell. Transp. Syst.*, pp. 52-57, 2000.
- D. Liu H. Liu and J. Xin. Real-time recognition of road traffic sign in motion image based on genetic algorithm. *Proc. 1st. Int. Conf. Mach.*, pp. 83-86, 2002.
- G. Loy and N. Barnes. Fast shape-based road sign detection for a driver assistance system. *Proc. Int. Conf. IROS.*, pp. 70-75, 2004.
- J. Miura, T. Kanda, Y. Shirai, An Active Vision System for Real-Time Traffic Sign Recognition. In *Proc. 2000 IEEE Int. Conf. on Intelligent Transportation Systems*, pp. 52-57, 2000
- E. Perez and B. Javidi. Nonlinear distortion-tolerant filters for detection of road signs in background noise. *IEEE Trans. Veh. Technol., vol. 51*, pp. 567-576, 2002.
- A. Ruta, Y. Li, and X. Liu, Traffic Sign Recognition Using Discriminative Local Features, M.R. Berthold, J. Shawe-Taylor, and N. Lavrac (Eds.): *IDA 2007*, LNCS 4723, pp. 355-366, Springer-Verlag, 2007.
- P. Viola, M. Jones, Robust Real-time Object Detection. *International Journal of Computer Vision 57(2)*, pp. 137-154, 2004
- P. S. Yen S. Cherng C. Y. Fang, C. S. Fuh and S.W. Chen. An automatic road sign recognition system based on a computational model of human recognition processing. *Comput. Vis. Image Underst.*, pp. 237-268, 2004.

Automated Safety Analysis of Vehicles Based on Qualitative Behavior Models and Spatial Representations

Peter Struss, Sonila Dobi
Tech. Univ. of Munich
{struss, dobi}@in.tum.de

Abstract

For automotive vehicles, safety analysis has been strongly enforced in recent years and is subject to international standards. The research presented in this paper aims at automating a major part of the process by exploiting qualitative model-based and spatial reasoning. This reflects the division of the problem and model into two parts: first, a qualitative model of the vehicle subsystem (the drive train of a truck in our case study) is used to predict the effect of a component fault on the behavior of the entire vehicle, such as an unintended acceleration. Secondly, the impact of this effect on the environment of the vehicle has to be determined, e.g. a collision of the vehicle with persons or objects. This requires a model of the environment and the interaction of the vehicle with it and, hence, a spatial representation of positions of the vehicle and other objects relative to the road and their interference under different scenarios.

1 Introduction

Analyzing whether a technical system performs safely even under the occurrence of a fault is of high importance when its failure may cause injury or death of humans or other severe damage to its environment. For automotive vehicles, safety analysis has been strongly enforced in recent years and is subject to international standards. This task, which may have to be carried out repetitively for different versions and variants during the design of a system, is knowledge-intensive and consumes significant efforts of experts.

We present the realization and evaluation of a prototypical solution to the problem in a case study on the drive train of a truck, which exploits qualitative modeling and a qualitative spatial representation. This reflects the division of the problem and model into two parts: modeling and inferring

- abnormal **behavior** of the **vehicle** (called **hazards**) under the presence of component **faults** and
- the **impact** of an **abnormal motion** of the vehicle on its **environment**.

The nature of the worst-case analysis (determining qualitative effects of classes of component faults under abstract classes of scenarios) requires the use of qualitative represen-

tations and models. Hence, in our case study, **qualitative behavior models** of the **components** of the drive train are used to predict the effect of a component fault on the motion of the entire vehicle, e.g. an unintended acceleration.

The analysis of the impact of this effect has to determine potential collisions due to the disturbed motion of the vehicle based on a **qualitative spatial representation** of positions of the vehicle and other objects relative to the road and their interference for different abstract scenarios.

The following section describes the application context of the task and the drive train case study. Section 3 discusses the requirements on a solution and gives a brief overview of our approach and its foundation. Automated model-based hazard analysis and the results are presented in sections 4 and 5, while the following two sections describe the impact analysis and its achieved results.

2 The Task

2.1 Safety Analysis in the Automotive Industries

The number of accidents, casualties, and injuries caused by automotive vehicles, but also other kinds of impact on the environment, e.g. through pollution, is a big concern and has led to many technical solutions (from anti-lock braking systems to sophisticated driver assistance systems), legal regulations (e.g. OBD2), practices and processes (Failure-modes-and-effects and criticality analysis, FMECA, Fault-tree analysis, FTA), and standards (e.g. IEC 61508).

Through a recent standard, ISO 26262 on Road Vehicle Functional Safety focusing on E/E (electrical and electronic) systems [ISO-26262, 11], the necessity to carry out thorough and vast analyses of vehicle safety and steps towards preventing unacceptable risks caused by system design or component failure has been greatly emphasized.

In the analysis phase, the causal relationships between faults occurring in the system and hazards, i.e. unintended behavior carrying the risk of damage, has to be determined, as well as under which scenarios this damage is likely to occur, with which severity, and whether it can be controlled by the driver. If unacceptable risks are not excluded, effective policies have to be introduced to the design (e.g. in terms of structural changes and redundancy, additional sensors, modified software functions).

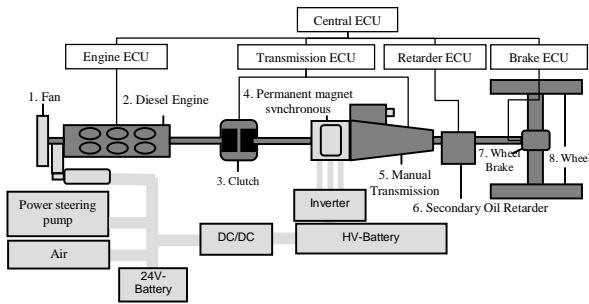

Figure 1. Drive Train Model

2.2 The Drive Train Case Study

Our industrial partner selected a drive train of a truck as the subject of a case study. Its structure is sketched in Fig. 1. The main part (in dark gray) comprises the engine, which produces torque for acceleration, but also for braking, the clutch, which may interrupt the propagation of torque, the transmission allowing to switch between forward and reverse torque (and idling), the retarder, a braking device that, when applied, counteracts the rotational motion through a propeller moving in oil, and the axle with the wheel, which transforms rotational acceleration into translational acceleration (and vice versa), and the wheel brakes. Components are controlled by specialized ECUs, which communicate with a central ECU that processes, for instance, the driver demands. The light-gray components are related to electrical aspects and are not discussed in this paper.

The industrial partner also supplied us with documents on exemplary problems and manually generated safety analysis tables. The core of an entry in such a table links a component fault (e.g. “erroneous CLOSE command to the clutch”), a special driving situation (“engine running, vehicle standing”), and a type of scenario (“vehicle in front of pedestrian crossing”) with a hazard (“unintended forward acceleration”) and its impact on the environment (“injury of persons”). Relevant impacts are typically hitting objects or persons, where, obviously, the severity is influenced by the type of object.

3 Requirements and the Approach

The background for our approach is illustrated by Figure 3: a cyber-physical system comprises a number of subsystems, which are systems composed of physical (mechanical, electrical, hydraulic, ..) components and software components, whose interaction happens exclusively through a usually relatively small set of sensor signals as an input to and actuator signals as an output of the software component(s). Different subsystems interact both via connections between their physical components and via communication between their software components. In a vehicle, the components of the drive train with their individual ECUs are examples for such subsystems. At a higher level, the drive train itself can

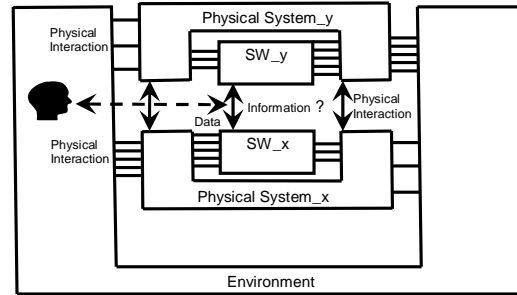

Figure 3. Cyber-physical Systems

be considered as a subsystem. The top level system is the entire vehicle.

From the perspective of safety analysis, it is important to note that it is **only** the vehicle as **physical** system that interacts with the environment. The embedded software never directly interferes with the environment. As a consequence, **hazards**, misbehaviors that bear the potential of damage in the environment, are defined **exclusively** at the intersection of the **physical system** and the **physical** environment. Whatever crazy operations may be carried out by the software – they are never a hazard per se. They may cause one via the response of the physical system to the actuator signals. A program has never hit a pedestrian.

As an important consequence, buggy software behavior matters if and only if it may cause the physical system to create a hazard. Therefore, our approach turns the (model of the) physical system into the center and models software – and especially software faults – solely with regard to the physical model.

In turn, hazards create risks only through their impact on the environment and other agents or objects. Obviously, this environment is much more diversified and dynamically changing compared to the designed artifact, the vehicle. It cannot be explored exhaustively, but only through certain abstract types of scenarios and driving situations as illustrated by the example mentioned in 2.2.

In consequence, we approach the task of building a tool for safety analysis by dividing it (conceptually) into two steps (Figure 2):

- **hazard analysis:** a **model of the vehicle** is used to determine whether assumed faults of (software or physical) components may result in (pre-defined) hazards for a set of specified **driving situations** (in terms of speed, driver actions, etc.) and **road conditions** (slope and surface friction),
- **impact analysis:** a **model of the environment**, including the vehicle and other objects and agents

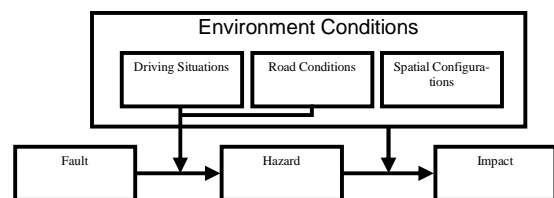

Figure 2. Hazard and Impact Analysis and their Inputs

determines whether the hazard may have a dangerous **impact** (in our case, a collision) under certain **environmental conditions**, which include the driving situation, road conditions (including curvature) and the spatial configuration of other objects.

The two models together associate component faults directly with safety violations and risks.

In this paper, we will ignore the impact of slope and friction, in assuming that friction suffices to strictly link torque and force and that the road is level.

Finally, we derive some design decisions from requirements and the inherent nature of the task. As emphasized before, the analysis is **highly repetitive**, in having to be performed several times during the design phase, applied to alternative designs, and subsequently to different versions and variants. Any proposed solution to supporting the process will only be economically beneficial if it does not suffer from the repetition itself. The answer to this challenge is **reuse of models**, i.e. **compositional modeling**, where system models are composed from component models in a library.

The nature of the analysis makes this actually feasible: it is an **inherently qualitative and a worst-case analysis**. Firstly, the analysis is performed at design time, and parameters may not yet have numerical values. Beyond this, the faults are qualitative: decreased friction of a brake, a leakage of a pipe, a high sensor signal etc. cannot be described by numerical values. Hazards are qualitative: too high or too low acceleration are not specified more precisely than this. Scenarios are qualitative: “a vehicle approaching a pedestrian crossing with medium speed” or “going downhill a winding road”. With regard to the required inferences, the worst-case analysis is not expected (and, given the qualitative input, not able) to firmly conclude the impact. What needs to be determined is the **potential** of a collision, given a reduced deceleration of the vehicle and, hence, a longer brake path – after all, we do not even know whether there will be any pedestrians present. And determining that a brake with reduced friction results in a reduced deceleration suffices to consider it as a reason for a risk in the respective scenario.

Hence, we need qualitative models and representations and inferences determining the possibility of hazards and severe impact. At this point, we note that the qualitative nature of the required models provides the basis for re-usable models and cheap model building. The impact on the level of abstraction of the models will be shown in the following sections.

4 Model-based Hazard Analysis

Hazard analysis, the first step of the process as indicated in Figure 2, is basically identical to the task of failure-modes-and-effects analysis (FMEA): assuming a (single) fault in the system, determine which of the pre-defined effects (=hazards) are or may be caused by it. (Multiple faults are considered only in combination with a single fault that is not detectable).

Hence, we need

- A **model** of the respective **system** (physical and software components), in which models of the component fault can be injected
- A definition of relevant **driving situations and road conditions**, for which the analysis has to be carried out
- A definition of the relevant **hazards**.

The following subsections describe these elements for the drive train case study, as well as the

- generic **inference mechanism** that derives the presence of hazards as a consequence of a component fault in a scenario.

4.1 Drive Train Model

In our work, we adopt the modeling approach proposed by [Struss and Fraracci, 12] as the basis for our model: since the analysis has to determine whether a deviation from nominal behavior in one component leads to a deviation in the behavior of the entire system, i.e. a hazard, we use a **model** stated in terms of how **deviations** are created and propagated through the system, rather than describing their behavior in absolute terms. We will illustrate this type of models with examples below.

The components of the drive train determine the **acceleration or deceleration** of the vehicle. More precisely, engine, crank shaft, clutch, gear box, retarder, and wheel brakes together determine the **torque** on the axle, and the wheel in interaction with the road surface transforms the torque into a translational acceleration of the entire vehicle – or not, if the friction between road surface and tire is low. Things get even more complicated, when the road has a non-zero slope and **gravity** adds a force that accelerates (or decelerates) the vehicle – again, dependent on friction: with sufficient friction, the gravity component along the road will add another torque to the axle (which may be overcome by other torques), otherwise, it will directly contribute to the translational acceleration of the vehicle (sliding downhill).

These considerations indicate that the modeling task is non-trivial. The issues to be addressed are

- The overall (deviation of the) torque applied cannot be determined locally, but only as the **combined impact** of several components.
- The transformation of **torque** into an **accelerating force** and vice versa
- The modeling of software components and, especially, **software faults**, which seems to be in the complexity class of clearing out the Augean stables.

We discuss these aspects in the following.

Deviation Models

We use deviation models in the same way as [Struss and Fraracci, 12]: the qualitative deviation of a variable x is defined as

$$\Delta x := \text{sign}(x_{\text{act}} - x_{\text{nom}})$$

which captures whether an actual (observed, assumed, or inferred) value is greater, less or equal to the nominal value. The latter is the value to be expected under nominal behavior.

ior, technically: the value implied by the model in which all components are in OK mode.

Faults may introduce non-zero deviations, e.g. the model of a worn brake would result in a deviating braking torque, which depends on the direction of the rotation (static friction)

$$\Delta T_{brake} = \omega$$

or the applied torque in case of kinetic friction

$$\Delta T_{brake} = T_{wheel}$$

Models of OK and faulty behavior are stated in terms of constraints on the deviations. For instance, a closed clutch simply propagates a deviating torque coming on the left from the engine to the right (flipping the sign):

$$\Delta T_{right} = -\Delta T_{left}.$$

Here, and throughout the paper, most variables have values from the domain $\text{Sign} = \{-, 0, +\}$: torques and forces, T and F, rotational and translational speeds, ω and v . The commands and states explicitly discussed here have Boolean values $\{0, 1\}$.

Space limitations do not permit presenting the entire model library. In the following, we try to outline the key ideas and illustrate them by selected component models.

Drive Train Modeling: Combining Torques

The core purpose of the drive train component models is to determine the (deviation of the) torque acting on the axle, which determines the (deviation of the) translational acceleration of the vehicle (if the road surface permits). As stated above, the overall torque results from the interaction of all components, which potentially contribute to it. The engine can produce a driving torque, the braking elements (wheel brake, retarder, engine) may generate a torque opposite to the rotation, and the clutch and transmission may interrupt or reverse the propagated torque.

Our current model is based on assuming that there are no cyclic structures among the mechanically connected components, which is the case in our application, but certainly also in a much broader class of systems. The component models link the torque (deviations) on the right-hand side to the one on the left-hand side, possibly adding a torque (deviation) generated by the respective component. Hence, at each location in the drive-train model, the torque (deviations) represent the sum of all torques collected left of it.

Whenever a terminal component (in our case the wheel) or a component in a terminal, i.e. open, state (the clutch and the transmission) is reached, the arriving torque is the total one for the section left, and for the open components, the torque on the right-hand side is zero, as exemplified by the clutch (state=0 means open):

$$state=1 \Rightarrow T_{right} = T_{left}$$

$$state=0 \Rightarrow T_{total} = T_{left} \wedge T_{right} = 0.$$

Determining the deviation models is not as straightforward, as it may appear, as we will explain using the model of retarder as an example. If engaged (state=1), it will generate a torque opposite to the rotation (zero, if there is no rotation) and add it to the left-hand one. The base model is obvious:

$$T_{right} = T_{left} \oplus T_{brake}$$

$$state = 1 \Rightarrow T_{brake} = - \omega$$

$$state = 0 \Rightarrow T_{brake} = 0,$$

where \oplus denoted addition of signs. The first line directly translates into a constraint on the deviations:

$$\Delta T_{right} = \Delta T_{left} \oplus \Delta T_{brake}$$

However, determining ΔT_{brake} requires consideration of how the actual state is related to the nominal one, which depends on the control command to the component, and, to complicate matters, not on the actual command, but the **command that corresponds to the nominal situation**. This means we have to model possibly deviating commands, and we apply the concept and even the definition of a deviation also to Boolean variables. For instance, in the retarder model, $\Delta state = -$ means $state = 0$ (i.e. it is not engaged) although it should be 1, and $\Delta state = +$ expresses that it is erroneously engaged. Such deviations could be caused by retarder faults, e.g. stuck-engaged. However, in the context of our analysis, we must consider the possibility that the commands to the retarder are not the nominal ones (caused by a software fault or the response of the correct software to a deviating sensor value). Under multiple faults, a component fault may even mask the effect of a wrong command (the retarder stuck engaged compensates for $\Delta cmd = -$). In the OK model of the retarder, it does what the command requests and the deviations of the command and state (i.e. the real, physical state) are identical:

$$\Delta state = \Delta cmd.$$

For a stuck engaged fault, however, Table 1 captures the constraint on the deviations:

Table 1. Retarder stuck engaged - Deviation constraint

cmd	Δcmd	$\Delta state$
1	0	0
0	0	+
0	-	0
1	+	+

Here, the third row represents the masking case mentioned above, while the first one reflects that the physical state coincides with the command, while in the second one, it does not.

From $\Delta state$, ΔT_{brake} is determined by

$$\Delta T_{brake} = - \omega \otimes \Delta state,$$

where \otimes denotes multiplication of signs. This completes the model of the retarder.

Software Models

Since the drive train contains a number of ECUs, we also need to include models of software **and its faults** in our library. Remember: all that matters about software faults is their impact on the physical system, more precisely, on the controlled actuator. For the Boolean commands in our model, this means the only fault types to be considered are

- **Missing** (or late) **command**: $\Delta cmd = -$
- **Untimely** (or early) **command**: $\Delta cmd = +$.

The same applies to continuous actuator signals, where the faults represent signal too low and too high, respectively.

This provides evidence for our claim that putting safety analysis back on its feet and the physical model in the center, greatly simplifies the modeling and analysis of the em-

bedded software. In particular, for the purpose of hazard analysis, we obtain a small set of reusable software models for our library. Of course, if we do have a more detailed model of the software, also the fault models can be more specific.

4.2 Driving Situations and Hazards

Whether a component fault causes a hazard is usually dependent of the context: if the retarder is stuck and, hence, applies a braking torque does not lead to a risk if the driver pushes the brake pedal, anyway. Therefore, hazard analysis (and FMEA) is carried out for certain different **driving situations**. From the material in our case study, we observed that there are relatively few of them. They can be characterized by the **vehicle velocity** and the **driver demand**, which is expressed by pushing the accelerator pedal or the brake pedal and selecting the gear.

The considered scenarios are normal **driving** (with or without intended acceleration), **starting**, and **braking** for both forward and backward motion. The forward ones are defined according to Table 2.

Table 2. Selected Definitions of Driving Situations

Driving situation	Accelerator pushed	Brake pedal pushed	Chosen gear			Clutch pedal not pushed	v
			F	N	R		
F-start	x		x			x	0
Drive high speed	x		x			x	++
Drive low speed	x		x			x	+
F-brake high speed		x	x			(x)	++
F-brake low speed		x	x			(x)	+

Also the hazards are predefined. For the drive train, the hazards are given by deviating acceleration of the vehicle (resulting from a deviating torque). Hence, the **basic hazards** are $\Delta a = +$ and $\Delta a = -$. From the perspective of FMEA, they may have a different intuitive meaning for different scenarios. For instance, $\Delta a = +$ means for the (forward) drive situation that the vehicle becomes faster than intended, while for the braking scenario, the braking torque is reduced or even zero. For supporting an intuitive interpretation of the hazards, we defined them in a scenario-specific way, as illustrated by Table 3, which shows only the definitions relevant for forward situations (several values in a cell represent a disjunction).

Table 3. Selected Hazard Definitions

Hazard	Driving Situation	a	Δa
Increased acceleration	Drive, F-start	+	+
Reduced or no acceleration	Drive, F-Start	+, 0	-
Unintended deceleration	Drive	-	-
Unintended backward accelera-	F-start	-	-

tion			
Reduced or no deceleration	F-brake	-, 0	+
Increased deceleration	F-brake	-	-
Unintended acceleration	F-brake	+	+

4.3 Prediction of Hazards

We have now collected the necessary ingredients for hazard analysis – (faulty) behavior models, $\{\text{MODEL}_f\}$, scenarios $\{\text{SCEN}_j\}$, which are identical to driving situations and the fixed road conditions, and hazards, $\{\text{HAZ}_k\}$. Each of them can be represented as a set of constraints or, if preferred, as first order formulas. Hazard analysis can then be formalized as the task of determining whether a hazard HAZ_k may occur under an assumed fault MODEL_f in a scenario SCEN_j :

$$\text{MODEL}_f \cup \text{SCEN}_j \cup \text{HAZ}_k \neq \perp,$$

or, stronger, is entailed by them:

$$\text{MODEL}_f \cup \text{SCEN}_j \models \text{HAZ}_k.$$

Hazard analysis then iterates over the Cartesian product of scenarios and faults and performs the above checks for each defined hazard using a constraint solver, in our case the FMEA engine of Raz’r [Raz’r 13].

4.4 Results of Automated Hazard Analysis

The system summarizes the results in a table, which represent a key part of the tables to be generated for FMEA or safety analysis. Table 4 shows a part of this table. With respect to the modeled component faults and the defined driving situations and hazards, the table is complete and correct. None of the entries in the table is surprising or difficult to obtain manually – but it is not the objective of this work to generate results the engineers could not produce. Instead, the goal is to automate the mechanistic part of their work. The manual production of the table costs at least tens of person hours, while the tool needs minutes. And the algorithm does not omit scenarios or faults or miss a hazard.

5 Model-based Impact Analysis

The hazard analysis described above yields the consequence of faults in terms of deviations in the motion of the vehicle, more specifically, deviation of its acceleration. Determining the **impact** of this deviation on the environment requires a representation that can express the location and motion of the vehicle as well as other objects in this environment as a basis for inferring the potential of collisions. As before, this analysis is carried out for different scenarios, where scenarios in this phase are seen as different **spatial configurations** of the vehicle and other objects. Besides their (potential) spatial extension, objects have an associated type (which influences the severity of the impact). As we saw above, hazards are qualitative, and so are the different spatial configurations in the environment, which represent classes of specific real situations, such as “street with persons on sidewalk” and “approaching exit on a freeway”. As a consequence, the required spatial representation has to be very

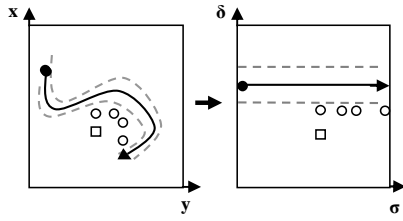

Figure 4. Transformation of the Coordinate System

abstract and qualitative, as described in the following section.

5.1 Spatial Representation

As opposed to other work that exploits spatial reasoning for exploring trajectories of moving objects and their spatial relations and predicting collisions based on particular situations (e.g. [Dylla et al., 2007]), we need to represent archetypes of situations, possible ranges of motions, and the potential of collisions.

To approach this and derive a simplified representation, we first abstract from the road as a 3D object:

- Although it may go uphill and downhill, the 3rd dimension is eliminated and only expressed as an attribute **slope** of the road, which influences the motion of the vehicle through gravitational force, which is already covered by the vehicle model.
- Although the road (or, more generally, the intended trajectory of the vehicle, as in “exiting from a freeway”) may have curves, which influences the impact (e.g. at high speeds), we also turn this into a (Boolean) attribute of the road, indicating whether the **curvature** is significant or not, and transform the space by turning the vehicle trajectory into one coordinate axis, σ , and the orthogonal distance from the road the other coordinate, δ , with the initial location of the vehicle in the origin, as illustrated by Figure 4.

Next, we abstract this space according to the distinctions that appeared in the natural language descriptions supplied by the industrial partner, i.e. we discretize \mathcal{R}^2 to a level that captures the qualitative distinctions needed to characterize locations and is able to infer a potential collision due to the (qualitatively) deviating motion of the vehicle. As an initial solution we chose the grid depicted in Figure 5. The grid is defined by qualitative positions 0 (at the vehicle), close, medium, far (both in front of and behind the vehicle) for σ , i.e. along the vehicle trajectory, and straight, right-of, medium-right-of, far-right-of (and the same for left) for δ , the

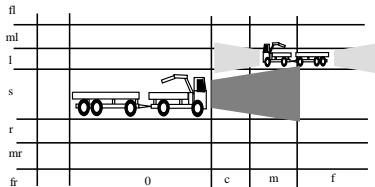

Figure 5. The Qualitative Spatial Representation

distance from the trajectory. The vehicle’s initial position will always be in (0, s), while pedestrians may cover the r-strip, or a median be located in the l-strip.

5.2 Impact Analysis

The environment is modeled as a “component” that is connected to the road (to retrieve its curvature attribute), the vehicle, and other objects which have a location and type, right now obstacles (immobile objects), other vehicles (with the potential to move fast, and persons (moving slowly).

The spatial interaction is modeled by **impact range constraints** that determine the potential positions of the vehicle and the other objects after the initial situation. For instance, a slowly driving vehicle with $\Delta a = +$ may reach positions (s, c) and (s, m). A fast, braking vehicle with $\Delta a = +$ on a road with non-zero curvature covers {(s, c), (s, m), (s, f), (l, m), (l, f), (ml, f), (r, m), (r, f), (mr, f)}.

Finally, the effects to be determined for this part of the analysis are modeled by **collision constraints** in the environment model: this can simply be encoded as “Equal” constraints on the potential locations of the vehicle and of another object. If these effects are consistent with a scenario, this means the impact ranges have a non-empty intersection and, hence, a collision is possible.

Formally and technically, impact analysis is carried out by Raz’r in the same way as hazard analysis (section 4.3), just with the hazards being replaced by the collisions.

An example for the automatically generated results is shown in Table 4. The results have been successfully validated on a set of standard situations supplied by our industrial partners.

Table 4. Partial Results of Automatic Hazard Analysis for “Approaching Freeway Exit, High Speed, Braking”

Part	Failure Mode	Hazard / Impact
CrankShaft1	Broken	:collision_with_object
Clutch1	ClutchStuckOpened	:collision_with_object
Clutch1	ClutchStuckClosed	:>>no system level effects<<
GearBox1	StuckReverse	:collision_with_object
GearBox1	StuckNeutral	:collision_with_object
GearBox1	StuckForward	:>>no system level effects<<
Retarder1	RetarderStuckNotEngaged	:collision_with_object
Retarder1	RetarderStuckEngaged	:>>no system level effects<<
Brakes1	StuckNotEngaged	:collision_with_object
Brakes1	StuckEngaged	:>>no system level effects<<

6 Outlook

The results obtained have triggered interest in pursuing this line of research. We are currently preparing a collaborative project involving automotive companies and academic partners (representing model-based approaches from AI and software engineering) that aim at providing tools for functional safety that are compliant with the standards and processes. This will require embedding the analytic part covered here with higher-level models from design and also feeding back its results to the process of responding to severe shortcomings by developing appropriate safety functions. Steps towards formal foundations for an integration of the model-based systems and software engineering technologies will be required for this.

References

- [Dylla et al., 2007] Frank Dylla, Lutz Frommberger, Jan Oliver Wallgrün, Diedrich Wolter, Bernhard Nebel and Stefan Wöfl. SailAway: Formalizing Navigation Rules. In *Proceedings of the Artificial and Ambient Intelligence Symposium on Spatial Reasoning and Communication*, AISB, pages 470-474, Newcastle upon Tyne, UK, April 2007.
- [ISO-26262, 11] ISO, "ISO 26262", international Standard ISO/FDIS 26262, 2011. [Online]. Available: <http://www.iso.org/>
- [Struss and Fraracci, 12] Peter Struss and Alessandro Fraracci. Automated Model-based FMEA of a Braking System. 8th IFAC Symposium on Fault Detection, Supervision and Safety of Technical Processes (Safeprocess 2012), Mexico City, 2012.
- [Raz' r 13] <http://www.occm.de/>

Group decision-making system based on a qualitative location function. An application to chocolates design

Núria Agell and Germán Sánchez

ESADE Business School

Universitat Ramon Llull

Av. Pedralbes 62, Barcelona (Spain)

{nuria.agell, german.sanchez}@esade.edu

Mónica Sánchez and Francisco J. Ruiz

BarcelonaTech

Jordi Girona, 1-3, Barcelona (Spain)

{monica.sanchez, francisco.javier.ruiz}@upc.edu

Abstract

When a group of experts is involved in the design of a new product as a team, consensus and Group decision making (GDM) techniques able to deal with complex descriptions are required. In addition, individual decisions based on human sensory perception, such as color, smell or taste, are usually qualitative and made under uncertainty. In this paper we consider a methodology based upon qualitative reasoning techniques for representing and synthesizing the information given by a group of experts in order to capture the sensorial aspects of the alternatives. A real application of the proposed GDM method to chocolates design has been conducted throughout 2012 with the Chocolate Chef Oriol Balaguer's team. We present the results obtained by applying the proposed methodology to aggregate experts' opinion during a creative session. In this session, some members of Oriol Balaguer's team tested and evaluated combinations of black chocolate with six different fruits, considered as alternatives, to select the best combination for the design and creation of a new cake.

1 Introduction

Creative industries with specialized professionals that use their sensory abilities for creating and designing their products, generate enormous challenges in managing and replicating these skills [13; 16]. The food, beverage, perfume, and other creative industries continuously face dilemmas in modeling the cognitive ability and processes of these highly specialized individuals [3]. The characteristics of these kinds of processes are not purely functional and physical, but arise from highly subjective perceptive and cognitive aspects. In fact, these processes entail special abilities in human senses such as taste (beverages, food, chocolate, etc.), smell (perfume, toiletries, etc.), vision (color and shape of products), touch (fabrics, materials finishes, etc.), or hearing (e.g. acoustic diagnosis) [9; 4; 16]. When a group of experts is involved in such a creative process as a team, consensus and group decision-making techniques able to deal with qualitative descriptions and uncertainty are needed.

Group decision-making (GDM) systems have been broadly investigated and used in different application areas, such as engineering, economics and management sciences [12; 14]. Their main interest is to allow decision makers (DMs) to reach a consensual solution without the need of neither their interaction nor a moderator, which leads to a less pressured and more anonymous participation [2; 11]. In general a team of experts has to rank a set of alternatives that are characterized by a set of conflicting attributes [10; 11; 17]. However, in the study carried out in this paper, and due to the sensorial condition of the alternatives to be ranked, the DMs evaluate each alternative as a whole, by means of qualitative linguistic labels corresponding to ordinal values [6; 7; 8]. Different levels of precision are considered to draw the distinctions required by the experts' sensorial decision processes.

In this paper we present an adaptation of the GDM method presented in [1] to capture the sensorial aspects of the alternatives. The method presented in this paper is based upon qualitative reasoning techniques for representing and synthesizing the information given by a group of experts and it can work at different precision levels. The scientific goals of the proposed methodology are representing, learning and predicting processes in a domain where perceived features are inherently vague, qualitative, imprecise, and often metaphorical. We present a real application that has been conducted throughout 2012 with Oriol Balaguer, a chocolate chef actively involved in creative cuisine concept. Frequently, highly recognized chocolate chef Oriol Balaguer before deciding the launch of a new product explores the sensorial perception of the newly created product among the members of his team.

The paper is structured as follows. First, the considered methodology of GDM is given in Section 2, where the absolute order-of-magnitude linguistic labels model is introduced and a distance among linguistic labels is considered. Then, in Section 3, the description of the problem of chocolates design is presented and the obtained experimental results are given. Finally, Section 4 contains the main conclusions and lines of future research.

2 Methodology

The methodology used in this paper is an adaptation of the method presented in [1] to capture the sensorial aspects of the alternatives to be ranked. For this reason, we consider an

order-of magnitude qualitative model with 5 basic linguistic labels totally ordered as a chain: $B_1 < \dots < B_5$ to describe the alternatives A_1, \dots, A_n .

2.1 The order-of-magnitude qualitative model

The *complete universe of description* for the order-of-magnitude qualitative space $OM(5)$, with granularity 5, is the set $S = \{B_1, \dots, B_5\} \cup \{[B_i, B_j] \mid i, j = 1, \dots, 5, i < j\}$, where the labels $[B_i, B_j]$ with $i < j$ are defined as $[B_i, B_j] = \{B_i, B_{i+1}, \dots, B_j\}$ and named ‘non-basic’ labels, and the set of basic labels is $S_* = \{B_1, \dots, B_5\}$ (see Figure 1). Although in Figure 1 all basic labels have the same length, this is only a symbolic representation and landmarks corresponding to the partition in level 1 can take any value (these values may even be unknown).

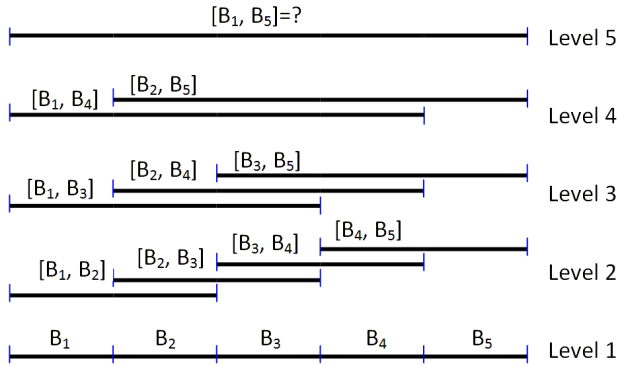

Figure 1: Linguistic hierarchy with five levels

Note that in S two partial order relations co-exist. The first one, the preference relation, (\leq), induced by the order in the set of basic labels S_* :

Definition 1. Let $[B_i, B_j], [B_r, B_s]$ be two elements of S , $[B_r, B_s]$ is *preferred* to $[B_i, B_j]$ if and only if $B_i \leq B_r$ and $B_j \leq B_s$, i.e.

$$[B_i, B_j] \leq [B_r, B_s] \iff (B_i \leq B_r \text{ and } B_j \leq B_s), \quad (1)$$

The second partial order relation, (\leq_P), considers the different levels of precision of the linguistic labels in S :

Definition 2. Let $[B_i, B_j], [B_r, B_s]$ be two elements of S , $[B_r, B_s]$ is *more precise* than $[B_i, B_j]$ if and only if $[B_r, B_s] \subset [B_i, B_j]$, i.e.

$$[B_r, B_s] \leq_P [B_i, B_j] \iff (B_r \leq B_i \text{ and } B_j \leq B_s), \quad (2)$$

In the complete universe of description S , five different granularities or levels of precision, from the basic labels to the most ambiguous non-basic label noted by $? = [B_1, B_5]$, can be handled (See Figure 1). Let us point out that the label $[B_i, B_j]$ corresponds to the concept ‘between B_i and B_j ’ and the less precise label ‘?’ is used to represent ‘unknown values’. The importance and need of linguistic labels with different levels of precision in consensus and GDM under uncertainty have been studied in depth [7; 10; 11].

2.2 Location function

To compute distances between m -dimensional vectors of labels corresponding to assessments of m DMs involved in a GDM problem, a first step involves codifying the labels in S by a location function:

Definition 3. The *location function* in S is the function $l : S \rightarrow \mathbb{Z}^2$ such that $l([B_i, B_j]) = (-(i-1), 5-j)$.

In this way, the location function codifies any label by considering the number of basic labels that are to its left and the number of basic labels that are to its right.

When a group of DMs D_1, \dots, D_m evaluates each alternative by means of a label belonging to S , their evaluations lead to a m -dimensional vector of linguistic labels for each alternative. Then, the location defined function positions each DM opinion.

Example 1. Let us consider 3 decision makers DM_1, DM_2 and DM_3 assessing one alternative in the absolute order-of-magnitude model with basic labels B_1, \dots, B_5 . Let $[B_3, B_4]$, $[B_2, B_5]$ and $[B_2, B_4]$ be their respective assessments. Then, the 3-dimensional vector of linguistic labels for this alternative is $([B_3, B_4], [B_2, B_5], [B_2, B_4])$. The locations of the labels $[B_3, B_4]$, $[B_2, B_5]$ and $[B_2, B_4]$ are respectively the pairs $(-2, 1)$, $(-1, 0)$ and $(-1, 1)$ (see Figure 2).

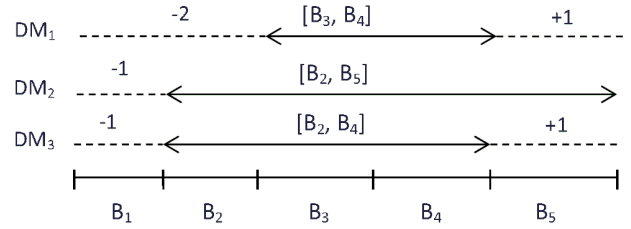

Figure 2: Three DMs assessments for one alternative

2.3 Ranking alternatives

Considering the assessments of all the m DMs, by means of the location function we obtain a $2m$ -dimensional vector of real numbers to represent each alternative. Then, the reference $2m$ -dimensional vector of real numbers $(-4, 0, \dots, -4, 0)$ is established considering that the assessments provided by all the DMs were B_5, \dots, B_5 , i.e. the maximum element of the space $OM(5)$. Finally to rank the alternatives, the Euclidean distance to this reference vector is computed for each alternative representation. The alternative with the smallest distance to the reference is selected. Note that weighted distances could be considered whenever the DMs have different status.

Following Example 1, the corresponding vector with the locations of the three DMs opinions is $(-2, 1, -1, 0, -1, 1)$ and the reference vector is $(-4, 0, -4, 0, -4, 0)$. This leads to a distance of $2\sqrt{6}$ to the reference vector of the considered alternative. In Example 2, the method is conducted to select the best of two alternatives.

Example 2. Let us consider 3 decision makers DM_1 , DM_2 and DM_3 assessing two alternatives A_1 and A_2 . The corresponding assessments are in Table 1 together with the vectors of locations and the distances to the reference. In conclusion, in this example, Alternative 1 is the selected one.

Table 1: Assessments of two alternatives

	A_1	A_2
DM_1	$[B_3, B_4]$	$[B_1, B_5]$
DM_2	$[B_2, B_5]$	$[B_2, B_3]$
DM_3	$[B_2, B_4]$	$[B_3, B_4]$
Vector of locations	$(-2, 1, -1, 0, -1, 1)$	$(-0, 0, -1, 2, -2, 1)$
Distance to the reference	$2\sqrt{6}$	$\sqrt{34}$

3 An application to chocolates design

The study conducted is based on data collected using the observations, knowledge, and experience of chocolate chef Oriol Balaguer’s team (<http://www.oriolbalaguer.com/>). At his atelier, master patissier and chocolate chef Oriol Balaguer has created a new style and fresh cuisine concept. He is actively involved in the research, creativity and development of new products. In 2002 he opened the first atelier of pastries and chocolates in Barcelona and since then Oriol Balaguer has 3 chocolate boutiques in Spain and several points of sale around the world, including Australia, China, Hong Kong, Japan, United Arab Emirates, USA and different European countries. His work has received numerous awards among which best dessert in the world in 2001 and Best patissier in Spain in 2008.

This section presents the results obtained in a *creative session* where a group of members of Oriol Balaguer’s team tasted and assessed the combinations of dark chocolate with six different fruits to select the best combination for the design and creation of a new cake.

To this end, initially a data set with 78 fruits was considered. In a previous session, Oriol Balaguer assessed the 78 fruits by means of labels in S with respect to their suitability to combine with dark, lait and white chocolate, according to his expertise and without tasting the combinations. The linguistic labels corresponding to the basic labels B_1, \dots, B_5 are shown in Table 2.

Table 2: Linguistic labels

Basic labels	Linguistic labels
B_1	it does not combine at all
B_2	it does not combine well
B_3	combines well
B_4	combines very well
B_5	it is an excellent combination

The assessment, conducted in a four hours session, was performed in a website based on PHP and MySQL (see Figure 3). Note that the expert was allowed to use different levels of precision to assess each chocolate-fruit combination (alternative).



Figure 3: Website for the previous session

As a result of this previous session, 51 fruits were assessed with respect to their suitability to combine with dark chocolate by means of linguistic labels in S different from $?$, while the expert assessed the remaining 27 fruits with the label $?$.

3.1 Experimental data

A Support Vector Machine (SVM) was trained with the 51 fruits assessed with linguistic labels in S different from $?$. The remaining 27 fruits were classified by the SVM as *suitable* or *not suitable* to combine with dark chocolate. A group of five fruits were positively classified by the SVM: red-bilberry, gooseberry, west Indian cherry, cashew fruit and guava. In addition, a negatively classified fruit (carambola) was added to the group, obtaining a set of six alternatives (one of them a false positive to control the process).

The selection between the six alternatives was performed applying the presented methodology to the assessments provided by five members of Oriol Balaguer’s team in a *creative session* (<http://www.esade.tv/home?idvideo=198261>). In this session, chocolate experts were asked to taste the combinations of the six fruits with dark chocolate, and come up with an assessment for each combination. The assessments were done individually and without any interaction between participants. Note that the chocolate chef Oriol Balaguer also participated in this creative session, because the fruits being tested and assessed were the ones assessed by him with the label $?$ in the previous session.

Creative session expert’s assessments were collected using a questionnaire with the same form of the website used in the previous session, but asking only about suitability to combine with dark chocolate (see Figure 4).

3.2 Results and discussion

The experts’ assessments are summarized in Table 3, where A_1, \dots, A_5 are respectively red-bilberry, gooseberry, west Indian cherry, cashew fruit, guava and carambola, and the last row contains their distances d to the reference.

It is important to remark that four out of five experts used different levels of precision in their assessments. Labels from levels 1, 2 and 5 can be found in their assessments.







Fruits		Dark Chocolate
	Red-bilberry	0 1 2 3 4 5 ☒ ■ ■ ■ ■ ■
	Gooseberry	0 1 2 3 4 5 ☒ ■ ■ ■ ■ ■
	West Indian cherry	0 1 2 3 4 5 ☒ ■ ■ ■ ■ ■
	Cashew fruit	0 1 2 3 4 5 ☒ ■ ■ ■ ■ ■
	Guava	0 1 2 3 4 5 ☒ ■ ■ ■ ■ ■
	Carambola	0 1 2 3 4 5 ☒ ■ ■ ■ ■ ■

Figure 4: Selected six fruits

Table 3: Experts' assessments

	A ₁	A ₂	A ₃	A ₄	A ₅	A ₆
DM ₁	[B ₄ , B ₅]	[B ₃ , B ₄]	B ₁	[B ₄ , B ₅]	B ₁	B ₁
DM ₂	B ₅	[B ₁ , B ₂]	[B ₂ , B ₃]	B ₃	[B ₁ , B ₂]	B ₁
DM ₃	B ₅	B ₃	B ₄	B ₅	B ₂	B ₁
DM ₄	B ₅	[B ₂ , B ₃]	B ₄	B ₅	[B ₁ , B ₂]	B ₁
DM ₅	B ₅	[B ₁ , B ₂]	B ₂	?	B ₃	B ₁
<i>d</i>	1.00	8.72	8.19	5.00	10.39	12.65

Table 3 shows that the alternative with the smallest distance to the reference is A₁. For this reason, A₁, red-bilberry, was the selected as the best alternative to combine with dark chocolate. Note that a consensus was reached among the group of experts about this selection: four of them assessed the combination *red-bilberry - dark chocolate* as an *excellent combination* and one expert assessed it as *between combines very well* and an *excellent combination*. Note also that all experts assessed the considered false positive combination (A₆, carambola) as the worse option, they all said *it does not combine at all*. Distances of the six alternatives to the optimum of *S* are represented in Figure 5.

Note that these distances provide us, not only a ranking of the alternatives, but also a pairwise comparison of the group's preferences between different alternatives.

4 Conclusion and future research

In this work, a GDM method has been presented to aggregate the opinions of experts into a group opinion. Each expert evaluates the alternatives by means of linguistic labels. The main positive aspects of the proposed methodology are: First, landmarks are not needed to define a discretization associated with basic linguistic labels. Second, it permits to easily work with different levels of precision to capture uncertainty in experts' assessments. Third, it allows decision makers to reach

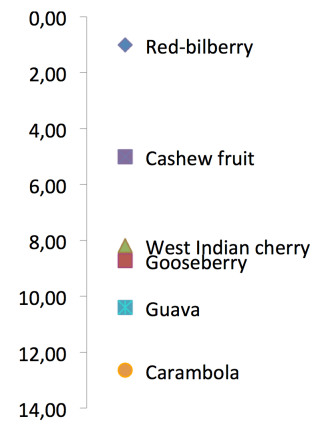

Figure 5: Distances to the optimum

a group solution without the need of neither their interaction nor a moderator.

We present a real application that has been conducted throughout 2012 with Oriol Balaguer, a chocolate chef actively involved in creative cuisine concept. We present and discuss the results obtained in a creative session where a group of members of Oriol Balaguer's team tasted and assessed six alternative combinations of dark chocolate with fruits. The selected best combination was used for the design and creation of a new chocolate cake.

These results show the capability of our methodology to capture the sensorial aspects of the proposed GDM problem. The experts agreed that using our model was advantageous, since it permits each of them to use the linguistic term that reflect more adequately the level of uncertainty intrinsic to his evaluation.

As future research, two main lines are currently under consideration. First, the development of a more general technique including several rounds of experts' participation and the definition of a degree of consensus to be introduced in a Delphi process. Second, more complex applications in creation, design and adjustment of products with important sensorial aspects, such as in the food, beverage, perfume, and other creative industries.

Acknowledgments

This research was partially supported by the SENSORIAL Research Project (TIN2010-20966-C02-01 and TIN2010-20966-C02-02), funded by the Spanish Ministry of Science and Information Technology. The authors would like to thank chocolate chef Oriol Balaguer and his team for their valuable contribution to this research. The authors would also like to acknowledge ESADECREAPOLIS for providing access to their facilities to conduct the creative session.

References

- [1] N. Agell, M. Sánchez, F. Prats, L. Roselló, Ranking multi-attribute alternatives on the basis of linguistic labels in group decisions, *Information Sciences* 209 (2012) 49-60.

- [2] Alonso, S., Herrera-Viedma, E., Chiclana, F., Herrera, F. 2010. A web based consensus support system for group decision making problems and incomplete preferences. *Information Sciences*, 180 (23), 4477-4495.
- [3] Banerjee, R., Tudu, B., Shaw, L., Jana, A., Bhattacharyya, N., & Bandyopadhyay, R. (2012). Instrumental testing of tea by combining the responses of electronic nose and tongue. *Journal of Food Engineering*, 110 (3), 356-363.
- [4] Cheetham, W. (2001) Benefits of case-based reasoning in color matching, in D.W. Aha, I. Watson (Eds.), *Case-Based Reasoning Research and Development, 4th International Conference on Case-Based Reasoning, ICCBR-01*, Vancouver, Canada, Lectures Notes in Computer Science, 2080, 589-596.
- [5] Forbus, K.D. 1996. *Qualitative reasoning*. CRC Handbook of Computer Science and Engineering. CRC Press.
- [6] Herrera, F., Herrera-Viedma, E., Martínez, L. 2000. A Fusion Approach for Managing Multi-Granularity Linguistic Term Sets in Decision Making, *Fuzzy Sets and Systems*, 114, 43-58.
- [7] Herrera, F. and Herrera-Viedma, E. 2000. Linguistic decision analysis: Steps for solving decision problems under linguistic information, *Fuzzy Sets and Systems*, 115, 67-82.
- [8] Jiang, Y.-P., Fan, Z.-P., Ma, J. 2008. A method for group decision making with multi-granularity linguistic assessment information. *Information Sciences*, 178, 1098-1109.
- [9] Konik, T., & Laird, J. (2006). Learning goal hierarchies from structured observations and expert annotations. *Machine Learning*, 1-3(64):263–287,
- [10] Ma, J., Lu, J., Zhang, G. 2010. Decider: A fuzzy multi-criteria group decision support system. *Knowledge-Based Systems*, 23, 23-31.
- [11] Parreiras, R.O., Ekel, P.Ya., Martini, J.S.C., Palhares, R.M. 2010. A flexible consensus scheme for multicriteria group decision making under linguistic assessments, *Information Sciences*, 180 (7), 1075-1089.
- [12] Porcel, C., Tejada-Lorente, A., Martínez, M.A., Herrera-Viedma, E. 2012. A hybrid recommender system for the selective dissemination of research resources in a Technology Transfer Office. *Information Sciences*, 184 (1), 1-19.
- [13] Seaborn, M., Hepplewhite, L., & Stonham, J. (2005). Fuzzy colour category map for the measurement of colour similarity and dissimilarity, *Pattern Recognition*, 38 (2), 165-177.
- [14] Serrano-Guerrero, J., Herrera-Viedma, E., Olivas, J.A., Cerezo, A., Romero, F.P. 2011. A google wave-based fuzzy recommender system to disseminate information in University Digital Libraries 2.0. *Information Sciences*, 181 (9), 1503-1516.
- [15] Travé-Massuyès, L. and Dague, P. 2003. *Modèles et raisonnements qualitatifs*. Ed. Lavoisier, Hermes Science, Paris, France.
- [16] Wright, J. (2010). *Creating and Formulating Flavours. Food Flavour Technology*, (A. J. Taylor and R. S. T. Linforth, eds), Wiley-Blackwell, Oxford, UK.
- [17] Xu, Z. 2004. Uncertain linguistic aggregation operators based approach to multiple attribute group decision making under uncertain linguistic environment. *Information Sciences*, 168 (2004), 171-184.
- [18] Xu, Z. 2008. A Method Based on the Dynamic Weighted Geometric Aggregation Operator for Dynamic Hybrid Multi-Attribute Group Decision Making. *International Journal of Uncertainty, Fuzziness and Knowledge-Based Systems*, 17 (1), 15-33.

An Immune Network Approach to Qualitative System Identification of Biological Pathways*

Wei Pang and George Macleod Coghill

School of Natural and Computing Sciences

University of Aberdeen

Aberdeen, UK, AB24 3UE

{pang.wei, g.coghill}@abdn.ac.uk

Abstract

In this paper we continue the research on learning qualitative differential equation (QDE) models of biological pathways building on previous work. In particular, we adapt opt-AiNet, an immune-inspired network approach, to effectively search the qualitative model space. To improve the performance of opt-AiNet on the discrete search space, the hypermutation operator has been modified, and the affinity between two antibodies has been redefined. In addition, to accelerate the model verification process, we developed a more efficient Waltz-like inverse model checking algorithm. Finally, a Bayesian scoring function is incorporated into the fitness evaluation to better guide the search. Experimental results on learning the detoxification pathway of Methylglyoxal with various hypothesised hidden species validate the proposed approach, and indicate that our opt-AiNet based approach outperforms the previous CLONALG based approach on qualitative pathway identification.

1 Introduction

Qualitative Differential Equation Model Learning (QML) [Pang and Coghill, 2010a] involves inferring the QDE model of a dynamic system from available data and background knowledge. QML is particularly suitable for situations where only sparse, noisy data and/or incomplete knowledge about the system are available. In the last three decades, a number of QML systems have been proposed to solve different problems and address various issues of QML. Examples of these systems include GEN-MODEL [Hau and Coiera, 1993], MISQ [Ramachandran *et al.*, 1994], QSI [Say and Kuru, 1996], QME [Varšek, 1991], and ILP-QSI [Coghill *et al.*, 2008] (formerly known as QOPH [Coghill *et al.*, 2002]).

In particular, in our previous work [Pang and Coghill, 2011] we developed a special-purpose QML system for qualitative system identification of biological pathways. In this

QML system we used an immune-inspired algorithm named CLONALG (the CLONal selection ALGORITHM) [de Castro and Zuben, 2002] as a search strategy. For ease of description, in this paper this QML system will be named QML_{PI}-CLONALG, where “PI” means pathway identification. QML_{PI}-CLONALG aimed to address two issues of QML: first, how to make better use of domain specific knowledge (biological knowledge); second, how to improve the scalability of QML when dealing with large-sized model spaces. In that research we proposed a CLONALG based algorithm for searching multimodal model spaces (search spaces containing multiple global or local optima), and promising results were obtained. However, due to the expensive computational cost of qualitative simulation, for complicated candidate pathways it was not possible to perform the actual qualitative simulation, and this prevented us from further investigating the performance of immune inspired QML for pathway identification.

In this paper, given the assumption that in a complicated pathway there are many hidden variables (those variables that cannot be measured by biological experiments) and only a few measured variables, which is a very common situation in biology, we first develop a more efficient way for model verification. This allows us to perform in-depth experiments on testing the performances of immune-inspired QML systems. In particular, we focus on exploring the potential of an alternative immune-inspired approach, opt-AiNet [de Castro and Timmis, 2002; Timmis and Edmonds, 2004], on learning QDE models of pathways because of its previously proven performance on multi-model search spaces. More importantly, as reported in our previous research [Pang and Coghill, 2010b] opt-AiNet is an effective search strategy for general-purpose QML systems, and it can achieve comparable performance to CLONALG. This motivates us to explore the potential of opt-AiNet as a search strategy for special-purpose QML systems, in particular, the QML system for pathway identification problems. The resulting QML system is named QML_{PI}-AiNet.

The rest of this paper is organised as follows: we first briefly introduce the basics about QDE models in Section 2. This is followed by a description of the algorithm for converting pathways to QDE models in Section 3. In Section 4 we give a formal description of the search space of the problem and define different kinds of pathways. The proposed

*WP and GMC are supported by the CRISP project (*Combinatorial Responses In Stress Pathways*) funded by the BBSRC (BB/F00513X/1) under the Systems Approaches to Biological Research (SABR) Initiative.

Table 1: The Signs Quantity Space

Quantity	Range
negative(-)	$(-\infty, 0)$
zero(0)	0
positive(+)	$(0, \infty)$

Table 2: Function Mappings Under the Signs Quantity Space

Function(A,B)	negative	zero	positive
negative	1	0	0
zero	0	1	0
positive	0	0	1

QML_{PI}-AiNet will be presented in Section 5, and the experiments to validate QML_{PI}-AiNet are detailed in Section 6. Finally Section 7 concludes the paper.

2 Qualitative Differential Equations

In this research we use the *Morven* framework [Coghill and Chantler, 1994; Bruce and Coghill, 2005] to represent QDE models. Formally, a QDE is defined as a tuple $\langle V, Q, C, T \rangle$ [Kuipers, 1994], where V represents the set of *qualitative variables*; Q is the set of *quantity spaces*, each of which is associated with a qualitative variable in V ; C is a set of *qualitative constraints* that apply to the variables in V ; T is a set of transitions between *qualitative states*. Simply speaking, a QDE is the conjunction of all its qualitative constraints, which link the qualitative variables and express the relations among these variables.

As for the set of quantity spaces Q , different qualitative reasoning engines may have different forms of representation, but all qualitative variables are restricted to only take qualitative values from their associated quantity spaces. The most commonly used and simplest quantity space is the *signs quantity space*, in which there are only three qualitative values: *positive*, *zero*, and *negative*, as shown in Table 1.

The set of qualitative constraints C are of two types: *algebraic constraints* and *functional constraints*. The former represent algebraic relations between variables as in quantitative mathematics, for instance, *addition*, *subtraction*, and *multiplication*; the latter describe incomplete knowledge between two variables, for example, the monotonically increasing and decreasing relations, which state that one variable will monotonically increase with the increase/decrease of another.

function constraints in the *Morven* framework are the above-mentioned functional constraints, and they define many-to-many mappings which allow flexible empirical descriptions between two variables without knowing the exact mathematical relation. One example of function mappings in *Morven* is shown in Table 2. In this table variables A and B use the signs quantity space as shown in Table 1; “1” stands for the existence of a mapping between variables A and B , and “0” otherwise.

Table 3 lists some *Morven* constraints and their corresponding mathematical equations. In this table variables in the right column such as $X(t)$ are continuous functions of time t . f is a function that is continuously differentiable over its domain. In the constraints listed in the left column of the

$A = \langle \text{pos}, \text{zer}, \text{zer} \rangle$
$B = \langle \text{pos}, \text{neg} \rangle$
$C = \langle \text{pos}, \text{zer} \rangle$

Figure 1: A Qualitative State

table, the label dt means *derivative*, and the integer immediately following it indicates which derivative of the variable (0 means the magnitude). This means each place in a *Morven* constraint can represent not only the magnitude, but also arbitrary derivative of a variable.

Table 3: Some qualitative constraints in *Morven* and their corresponding mathematical equations

<i>Morven</i> Constraints	Mathematical Equations
sub (dt 0 Z, dt 0 X, dt 0 Y)	$Z(t) = X(t) - Y(t)$
mul (dt 0 Z, dt 0 Y, dt 0 X)	$Z(t) = Y(t) \times X(t)$
div (dt 0 Z, dt 0 Y, dt 0 X)	$Z(t) = Y(t)/X(t)$
Function (dt 0 Y, dt 0 X)	$Y(t) = f(X(t))$
sub (dt 1 Z, dt 0 X, dt 0 Y)	$dZ(t)/dt = X(t) - Y(t)$
Function (dt 1 Y, dt 0 X)	$dY(t)/dt = f(X(t))$

After qualitative simulation of a QDE model, the output could be either an *envisionment* containing all possible *qualitative states* and their legal transitions, or a behaviour tree which is part of the envisionment. A qualitative state is a complete assignment of qualitative values to all qualitative variables of the system. Suppose there are only three variables A , B , C in a QDE model, and all of them use the signs quantity space, one possible qualitative state is shown in Figure 1, where *pos*, *neg*, and *zer* stand for positive, negative, and zero, respectively.

3 From Pathways to QDE Models

As in [Pang and Coghill, 2011], we consider that a pathway P is composed of several biochemical reactions, including the enzymatic and non-enzymatic ones. We also make standard biological assumptions on the pathway, that is, all enzymatic reactions follow the Michaelis-Menten kinetics, and all non-enzymatic reactions obey the law of mass action. For a non-enzymatic reversible reaction, $A+B \rightleftharpoons C+D$, according to the law of mass action the reaction rate is:

$$\begin{aligned} V &= K_1[A][B] - K_2[C][D] \\ &= -\frac{1}{a} \times \frac{d[A]}{dt} = -\frac{1}{b} \times \frac{d[B]}{dt} = \frac{1}{c} \times \frac{d[C]}{dt} = \frac{1}{d} \times \frac{d[D]}{dt}, \end{aligned} \quad (1)$$

where K_1 and K_2 are the rate constants of the forward and backward reaction respectively; a , b , c , and d are stoichiometric coefficients; $[A]$, $[B]$, $[C]$ and $[D]$ stand for concentrations of the corresponding species. For an enzymatic reaction $A \rightarrow B$, the reaction rate V is defined as follows:

$$V = -\frac{d[A]}{dt} = \frac{d[B]}{dt} = V_{max} \times \frac{[A]}{k_s + [A]}. \quad (2)$$

In the above, V_{max} and k_s are constants. We can see that with the increase of the concentration of A , the reaction rate will increase too. This can be considered as a monotonically increasing relation in the qualitative context.

Table 4: The Qualitative Model for an Example Pathway

Index	Qualitative Constraints	Mathematical Equations
<i>c1</i>	mul (dt 0 Aux1, dt 0 A, dt 0 B)	Aux1=A × B
<i>c2</i>	Function (dt 0 Aux2, dt 0 Aux1)	Aux2=f(Aux1) ($f' > 0$)
<i>c3</i>	mul (dt 0 Aux3, dt 0 C, dt 0 D)	Aux3=C*D
<i>c4</i>	Function (dt 0 Aux4, dt 0 Aux3)	Aux4=f(Aux3) ($f' > 0$)
<i>c5</i>	sub (dt 0 Aux5, dt 0 Aux2, dt 0 Aux4)	Aux5=Aux2-Aux4
<i>c6</i>	Function (dt 0 Aux6, dt 0 B)	Aux6=f(B) ($f' > 0$)
<i>c7</i>	Function (dt 0 Aux7, dt 0 E)	Aux7=f(E) ($f' > 0$)
<i>c8</i>	sub (dt 1 A, dt 0 Aux2, dt 0 Aux4)	d A/dt=Aux2-Aux4
<i>c9</i>	sub (dt 1 B, dt 0 Aux5, dt 0 Aux6)	d B/dt=Aux5-Aux6
<i>c10</i>	sub (dt 1 C, dt 0 Aux7, dt 0 Aux5)	d C/dt= Aux7-Aux5
<i>c11</i>	sub (dt 1 D, dt 0 Aux4, dt 0 Aux2)	d D/dt= Aux4-Aux2
<i>c12</i>	sub (dt 1 E, dt 0 Aux6, dt 0 Aux7)	d E/dt= Aux6-Aux7

Based on Equations (1) and (2), a possible pathway can be converted into a QDE model by the converting algorithm, details of which can be found in [Pang and Coghill, 2011]. In this way we can perform the search in the pathway level, that is, search all reasonable pathways, rather than in the qualitative constraint level as in [Pang and Coghill, 2010b], e.g., search all possible QDE models directly. This will significantly reduce the size of the search space. For instance, considering the following simple pathway which is composed of only three reactions:

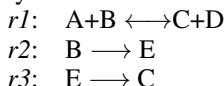

Using the converting algorithm, we can convert the above pathway into a QDE model (using the *Morven* formalism), as shown in Table 4. In this table, Constraints *c1*~*c5* and *c8*~*c11* are related to Reaction *r1*; Constraints *c6*, *c9*, and *c12* are related to Reaction *r2*; Constraints *c7*, *c10*, and *c12* are related to Reaction *r3*. In this table variables whose names start with "Aux" are called auxiliary variables, which are used to break down long equations so that the qualitative constraints can be used (more details may be found in [Pang and Coghill, 2011]). All Function constraints in this table represent monotonically increasing relations, and their mappings are as shown in Table 2.

From Table 4 we see that for a simple pathway consisting of three reactions, the corresponding QDE model contains 12 constraints. This means it will be easier to perform the search at the reaction level rather than at the qualitative constraint level, because at the qualitative constraint level the search space is much bigger.

4 The Search Space, Reasonable and Candidate Pathways

For a pathway *P* to be identified, given all the species involved in this pathway and the standard assumptions about enzymatic and non-enzymatic reactions mentioned in Section 3, we can generate all possible reactions by enumerating all combinations of species and reaction types. These reactions are further partitioned into several subgroups, each of which contains all reactions having the same reactants. Suppose *SS* is the set containing all these subgroups:

$$SS = \{S_1, S_2, \dots, S_n\}. \quad (3)$$

In the above S_i ($1 \leq i \leq n$) contains all possible reactions with the same combination of reactants. In addition, for ease

of implementation, we add a "dummy" reaction in each S_i , denoted ϕ . If a dummy reaction ϕ is selected in S_i , the pathway will not include any reaction from S_i .

Definition 1 Possible Pathway. A possible pathway is constructed by selecting one and only one reaction (including the dummy reaction) from each S_i in *SS*.

This is because one combination of reactants can only lead to unique products. Accordingly, the size of the search space containing all possible pathways is

$$|SS_P| = \prod_{i=1}^n |S_i|. \quad (4)$$

In the above SS_P stands for the search space for the pathway *P*. $|SS_P|$ and $|S_i|$ denote the size of the search space and the number of reactions in the subset S_i , respectively.

Definition 2 Reasonable Pathway. A reasonable pathway is a possible pathway that satisfies the following constraints: (1) *Completeness*: a pathway must include at least all given species. (2) *Consistency*: there are no conflicting reactions. (3) *Connection*: there is no disjoint section in the pathway. (4) *Domain-specific constraints*: a pathway must satisfy additional constraints extracted from domain knowledge.

Definition 3 Candidate Pathway. If the QDE model of a reasonable pathway can cover given qualitative data (GQD), this pathway is a candidate pathway with respect to GQD.

It is noted there are often many candidate pathways for GQD because the model space is often highly multimodal. For each candidate pathway, we calculate its Bayesian score to indicate the probability of this pathway being the right one.

Definition 4 Bayesian Score of a Candidate Pathway. The Bayesian Score of a candidate pathway is the Bayesian score of the QDE model converted from this candidate pathway.

The Bayesian score of a QDE model is calculated according to Muggleton’s learning from positive data framework [Muggleton, 1996], as shown below:

$$Bayes(M) = p \ln \frac{1}{g(M)} - \ln sz(M) \quad (5)$$

In the above $sz(M)$ is the size of the given QDE model *M*, $g(M)$ is the generality of the model, and p is the number of positive examples. So this Bayesian scoring is the tradeoff between the size and generality of a model. Based on previous work [Coghill *et al.*, 2008], in Equation (5) $sz(M)$ is estimated by summing up the sizes of all constraints; $g(M)$ is defined as the proportion of qualitative states obtained from simulation to all possible qualitative states generated from given variables and their associated quantity spaces; p is the number of given qualitative states.

The bigger the Bayesian score of a candidate pathway, the higher the probability that this pathway is the correct model. In this research, the above described Bayesian score is incorporated into the fitness evaluation to guide the search.

5 QML_{PI}-AiNet

In this section the detailed implementation of QML_{PI}-AiNet will be presented.

5.1 Antibody Encoding and Decoding

Similar to QML_{PI}-CLONALG, an antibody in QML_{PI}-AiNet is composed of several slots, each of which corresponds to a reaction subset S_i in SS described in Equation (3). In contrast to the integer encoding for antibodies in QML_{PI}-CLONALG, in QML_{PI}-AiNet the real number encoding is used, which is the same encoding strategy as in the original opt-AiNet. An antibody is represented as follows:

$$Ab = \{Sl_1, Sl_2, \dots, Sl_n\}. \quad (6)$$

In the above Ab stands for an antibody; Sl_i ($1 \leq i \leq n$) represents the value assigned to the corresponding slot of Ab , satisfying $Sl_i \in \mathbf{R}$ and $1 \leq Sl_i \leq |S_i|$.

As the real number encoding strategy is used, when we decode an antibody, each value Sl_i will be rounded off to its nearest integer, denoted as $[Sl_i]$. If Sl_i is in the middle of two integers, the smaller integer will be taken. Then the newly obtained integer for each slot will be used as an index to retrieve the corresponding biochemical reaction in each S_i . So after the decoding of an antibody represented by Equation (6), the following pathway P will be obtained:

$$P = \{R_{[Sl_1]}, R_{[Sl_2]}, \dots, R_{[Sl_n]}\}. \quad (7)$$

In the above $R_{[Sl_i]}$ means the $[Sl_i]$ -th reaction in S_i .

Figure 2 shows an example of the antibody encoding and decoding in QML_{PI}-AiNet. In this figure, the antibody has n slots, which correspond to S_1, S_2, \dots, S_n in SS described in Equation (3), respectively. In Slot 1 the current value is 2.1. After decoding we get an integer 2, so the second reaction r_2 in S_1 is selected (indicated in bold font). It is similar for the other slots. After decoding the pathway contains reactions r_2, r_{12} , and r_{91} .

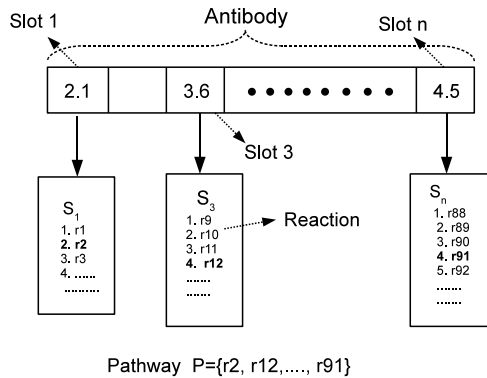

Figure 2: The Antibody Encoding and Decoding of QML_{PI}-AiNet

5.2 Fitness Evaluation

We note here that in QML_{PI}-CLONALG this process is called the affinity evaluation. In QML_{PI}-AiNet the affinity has a different meaning which will be defined later in Section 5.4. In the fitness evaluation process of QML_{PI}-AiNet,

an antibody is first decoded into a pathway, then this pathway is checked against the reasonable pathway constraints, as given in **Definition 2**. The more constraints a model satisfies, the higher fitness value this model will get.

If this pathway is a reasonable one, it will be converted to a QDE model (as described in Section 3) and checked against the given data. In previous work [Pang and Coghill, 2011], we checked the model coverage by qualitative simulation with *Morven*. However the qualitative simulation is very computationally expensive for large-sized models. In this research, considering the situation that in a complex pathway only a few variables can be measured, instead of simulating the model converted from a pathway, we inversely check whether the given qualitative states can make the model consistent, or in other words, make all qualitative constraints of the model consistent. This is done by using a Waltz-like constraint propagation algorithm as described in [Davis, 1987] when we consider a QDE model as a constraint network with each variable being a node and each qualitative constraint being a link.

After the data coverage of a pathway has been checked, if this pathway is a candidate pathway according to **Definition 3**, we can further calculate the Bayesian score of this pathway according to **Definition 4**, and the obtained Bayesian score will be added into the total fitness value to guide further search.

5.3 Mutation

The original mutation operator of opt-AiNet was defined for continuous problems. Considering the discrete qualitative model space, the following mutation operation is proposed for each slot of the antibody:

$$C' = \begin{cases} U(1, n) & \text{if } U(0, 1) < \alpha N(0, 1) \\ C & \text{otherwise} \end{cases} \quad (8)$$

$$\alpha = \frac{1}{\beta} e^{-f^*} \quad (9)$$

In the above, C' and C are the mutated value and current value for one slot of the antibody, respectively. $U(0, 1)$ is a uniformly distributed random number with the range $[0, 1]$. Similarly, $U(1, n)$ stands for a uniformly distributed random number with the range $[1, n]$, where n is the number of constraints in the current slot of the antibody. $N(0, 1)$ is a Gaussian random variable which has a mean value of 0 and standard deviation of 1. f^* is the normalised fitness with the range $[0, 1]$. e^{-f^*} is the inverse exponential function. α stands for the amount of mutation, and β is a parameter that adjusts the exponential function. This new mutation operator first determines whether a slot should be mutated. The probability of mutating is proportional to the fitness value of the current antibody. Once the current slot is set to mutate, the mutation will follow the uniform distribution.

5.4 Affinity

In opt-AiNet the affinity is defined as the Euclidean distance between two antibodies. In QML_{PI}-AiNet because we use the integer decoding strategy, and each antibody represents a possible pathway composed of several reactions, we define

the affinity between two antibodies as “the degree of dissimilarity” between two pathways represented by the two antibodies. The degree of dissimilarity between two pathways is calculated by simply counting the number of different reactions in these two pathways.

5.5 The Detailed Steps of QML_{PI}-AiNet

The steps of QML_{PI}-AiNet follow the framework of opt-AiNet. First we list the parameters used by the algorithm in Table 5. The steps of the proposed QML_{PI}-AiNet algorithm

Table 5: Parameters in QML-AiNet

Name	Meaning
N_i	Number of initial antibodies in the population
N_c	Number of clones for each antibody
$AvgFitError$	Threshold determines the stability of population
$Supp$	The suppression threshold
d	The percentage of new antibodies to be added into the population
β	control parameter for mutation

are given in detail as follows:

Step 1: Randomly generate N_i antibodies.

While (stop criteria are not satisfied) iteratively execute *Step 2* ~ *Step 4*:

Step 2: Clonal Selection

- *Step 2-1:* Antibody fitness evaluation: calculate the fitness values of all antibodies according to the description in Section 5.2.
- *Step 2-2:* Clone: Generate N_c clones for each antibody.
- *Step 2-3:* Mutation: Each antibody will be mutated according to the description in Section 5.3. In particular, the original and modified mutation operators will both be tested.
- *Step 2-4:* Fitness Evaluation: evaluate all the newly cloned antibodies. Calculate the normalised fitness value for each antibody.
- *Step 2-5:* Selection: Select the antibody which has the biggest fitness value from each parent antibody and its clones. All the selected antibodies construct a new antibody population.
- *Step 2-6:* Average Fitness Error Calculation: Calculate the average fitness of the new population. If the difference between the old average fitness and new average fitness is bigger than the given threshold $AvgFitError$, repeat Step 2; otherwise proceed to Step 3.

Step 3: Network Suppression: Each antibody interacts with others. If the affinity of two antibodies (defined in Section 5.4), is less than the suppression threshold $Supp$, the one with the smaller fitness value will be removed.

Step 4: Add d percent of the randomly generated antibodies to the population.

6 Experiments

In this section we will test the performance of QML_{PI}-AiNet by a series of experiments, and also compare it with that of QML_{PI}-CLONALG.

Table 6: Some Qualitative Data Provided

MG	G	H	S
<pos,pos>	<pos,pos>	<pos,neg>	<pos,neg>
<pos,zer>	<pos,pos>	<pos,neg>	<pos,neg>
...

More specifically, we will complete and extend the experiments in [Pang and Coghill, 2011]. In [Pang and Coghill, 2011], for learning the MG pathway, we assumed different numbers of hidden variables and tested how well QML-CLONALG could find candidate pathways compared to other algorithms. However, the use of qualitative simulation to test the data coverage of models restricted us from testing the algorithm on more complicated pathways, and we have to ignore the data coverage tests for such complicated pathways because the corresponding qualitative simulation is very expensive. In this sense some of the previous experiments performed in [Pang and Coghill, 2011] are not complete.

In this research, we will use the more efficient Waltz-like inverse checking algorithm to verify models as mentioned in Section 5.2, which enables us to perform the *full* experiments which include the data coverage test.

6.1 The MG pathway

According to the current (incomplete) understanding, the MG detoxification pathway is composed of one non-enzymatic reaction and two enzymatic reactions, as shown below:

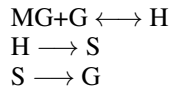

In the above, MG stands for Methylglyoxal; G stands for glutathione; H is hemithioacetal; S is S-lactoyl-glutathione. The first reaction is a reversible one and follows the mass action law. The second and third enzymatic reactions are irreversible and catalysed by GlxI (glyoxalase I) and GlxII (glyoxalase II), respectively, and they are assumed to conform to Michaelis-Menton kinetics. As the exact mechanisms of the MG detoxification are still not fully understood, given qualitative data, we can hypothesise different numbers of hidden variables and try to reconstruct the pathway.

6.2 Qualitative Data

The qualitative data are obtained by simulating the qualitative model converted from the current understanding of the MG pathway. In the simulation, all variables take the signs quantity space as described in Table 1. In all experiments, the same qualitative data are provided. There are a total of 33 qualitative states, and only some of the states are listed in Table 6 due to limited space.

6.3 Experimental Settings

Based on the current understanding of the MG pathway, we hypothesise three, five, seven, and nine hidden variables, which gives us four sets of experiments, and these four sets of experiments are called MG-3Hid, MG-5Hid, MG-7Hid, and MG-9Hid, respectively. For all four sets of experiments, we make the following reasonable assumptions: (1) there is one mass action reaction, and one of the reactants of this reaction

Table 7: Experimental Settings

Experiment Set	Species	Search Space
MG-3Hid	M, G, H, S, A, B, C	1.38×10^{13}
MG-5Hid	M, G, H, S, A, B, C, D, E	1.93×10^{20}
MG-7Hid	M, G, H, S, A, B, C, E, E, F, I	1.21×10^{28}
MG-9Hid	M, G, H, S, A, B, C, E, E, F, I, J, K	2.48×10^{36}

must contain Methylglyoxal; (2) the number of enzymatic reactions is unknown. Each set of experiments will be learnt by both QML_{PI} -CLONALG and QML_{PI} -AiNet, and we will also use the completely random algorithm as baselines.

The experimental settings are listed in Table 7. In this table M, G, S, H are the four identified species in the pathway, and A~K are hypothesised hidden species. All the experiments were performed on a computer cluster with 43 compute nodes, and each node has two Intel XEON E5520 (2.268GHz) quad-core processors and 12GB RAM). To ensure a fair competition, all algorithms are restricted to use a maximum of 4GB memory for all experiments.

6.4 Experimental Results

The experimental results are listed in Table 8. In this table we tested the performance of three algorithms on the four experiment sets, and recorded the number of candidate pathways and pathways with highest Bayesian scores found by each algorithm. All algorithms were run for ten trials, and the best and average performance (with standard deviation) were recorded. Each algorithm was run for 2,000 seconds. The parameter settings for QML_{PI} -AiNet are as follows: $N_i=20$; $N_c=10$; $AvgFitError=0.001$; $supp$ is 10 for MG-9Hid, 9 for MG-7Hid, 7 for MG-5Hid, 5 for MG-3Hid; $d=0.2$; $\beta=1$. The parameter settings for QML_{PI} -CLONALG are as follows: the clonal size is 10; the hyper-mutation probability is 0.1; the population size is 100 for MG-3Hid, 1000 for other experiment sets. The values of parameters are chosen according to either classical values taken in both algorithms or considering the complexity of the search space and the performance of the search.

From the results shown in Table 8 we see that with the increase of the size of the search space, QML_{PI} -AiNet performs better and better than QML_{PI} -CLONALG in terms of the number of candidate pathways found as well as the quality of the best solutions measured by Bayesian scores. This is also illustrated in Figures 3 and 4, which show the detailed experimental results for MG-7Hid. From Figure 3 we can see that in average QML_{PI} -AiNet found one order of magnitude more candidate pathways than QML_{PI} -CLONALG, which well demonstrated the ability of QML_{PI} -AiNet to deal with multimodal search spaces. From Figure 4 we can also see that QML_{PI} -AiNet found pathways with higher Bayesian scores and converged to the highest Bayesian score more quickly compared with QML_{PI} -CLONALG. This indicates that QML_{PI} -AiNet can better deal with large-scale multimodal qualitative model spaces than QML_{PI} -CLONALG.

7 Conclusions and Future Work

In this paper, we have presented an immune network approach to learning QDE models of biological pathways. The

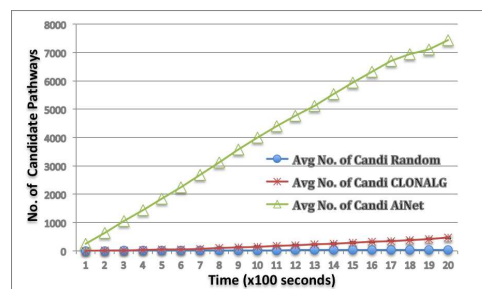

Figure 3: Experimental Results for MG-7Hid: Average Number of Candidate Models Found Over Ten Trials

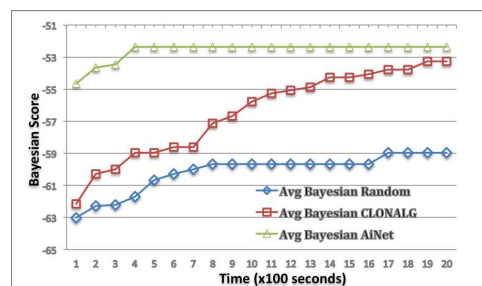

Figure 4: Experimental Results for MG-7Hid: Average Bayesian Score of the Best Candidate Model Over Ten Trials

proposed QML_{PI} -AiNet employs an opt-AiNet based search strategy to search the qualitative model space, which could be highly multimodal given incomplete knowledge and data.

A comparison of the performance of QML_{PI} -AiNet with the previous system QML_{PI} -CLONALG indicates that the proposed QML_{PI} -AiNet can better deal with highly multimodal qualitative model spaces, and is also more scalable to large search spaces. Given the same computational resources, in all experiments QML_{PI} -AiNet outperformed QML_{PI} -CLONALG. This indicates that QML_{PI} -AiNet is a very suitable special-purpose QML system for qualitative pathway identification.

Finally, it is noted that the proposed special-purpose immune network approach to QML can be generalised to solve other real-world applications, such as identification of economic, mechanical, and electrical systems, provided a method of converting models representing such real-world applications to QDE models is developed. In the future work, we will consider the situations where there are noisy qualitative states or only a few qualitative states are available, which is similar to previous study [Pang and Coghill, 2007; Coghill *et al.*, 2008] on general-purpose QML systems. How to make QML_{PI} -AiNet adapt to these situations will become a challenging task.

References

- [Bruce and Coghill, 2005] A. M. Bruce and G. M. Coghill. Parallel fuzzy qualitative reasoning. In *Proceedings of the 19th International Workshop on Qualitative Reasoning*, pages 110–116. Graz, Austria, 2005.

Table 8: Experimental Results

Experiment ID	Algorithm	No. of Candidate Pathways		No. of Best Pathways		Highest Bayesian Scores	
		Best	Average (STDEV)	Best	Average (STDEV)	Best	Average (STDEV)
MG-3Hid-1	Random	668	600.3(67.91)	30	4.9(8.88)	-24.37	-24.86(1.58)
MG-3Hid-2	CLONALG	2148	1760(235.38)	20	15.6(4.62)	-24.37	-24.37(0)
MG-3Hid-3	AiNet	5993	5244(292.62)	29	27.3(2.50)	-24.37	-24.37(0)
MG-5Hid-1	Random	170	126.3(26.75)	12	3(3.30)	-41.37	-43.39(1.00)
MG-5Hid-2	CLONALG	1529	1156.1(242.16)	19	9(5.62)	-38.37	-38.37(0)
MG-5Hid-3	AiNet	8677	7770.4(573.38)	153	118.4(19.22)	-38.37	-38.37(0)
MG-7Hid-1	Random	51	39.2(7.33)	22	4.2(6.43)	-52.37	-58.96(2.63)
MG-7Hid-2	CLONALG	652	462.3(143.54)	9	3.5(2.42)	-52.37	-53.57(1.55)
MG-7Hid-3	AiNet	9271	7439(789.27)	217	163.6(45.75)	-52.37	-52.37(0)
MG-9Hid-1	Random	19	12.6(4.300)	4	1.9(1.10)	-73.60	-76.30(0.95)
MG-9Hid-2	CLONALG	265	182.4(56.07)	1	1(0)	-71.37	-71.97(0.52)
MG-9Hid-3	AiNet	11406	7455.5(2827.18)	238	131.7(53.53)	-66.37	-66.37(0)

- [Coghill and Chantler, 1994] George M. Coghill and M. J. Chantler. Mycroft: a framework for qualitative reasoning. In *Second International Conference on Intelligent Systems Engineering*, pages 43 – 48, Hamburg, Germany, September 1994.
- [Coghill *et al.*, 2002] George M. Coghill, S. M. Garrett, and R. D. King. Learning qualitative models in the presence of noise. In *Proc. 16th International Workshop on Qualitative Reasoning (QR'02)*, pages 27–36, Sitges, Spain, June 2002.
- [Coghill *et al.*, 2008] George M. Coghill, Ashwin Srinivasan, and Ross D. King. Qualitative system identification from imperfect data. *Journal of Artificial Intelligence Research*, 32:825–877, 2008.
- [Davis, 1987] Ernest Davis. Constraint propagation with interval labels. *Artificial Intelligence*, 32(3):281–331, July 1987.
- [de Castro and Timmis, 2002] de Castro and Jon Timmis. An artificial immune network for multimodal function optimization. In *Proceedings of IEEE Congress on Evolutionary Computation (CEC'02)*, pages 674–699. IEEE Press, 2002.
- [de Castro and Zuben, 2002] de Castro and Fernando J. Von Zuben. Learning and optimization using the clonal selection principle. In *IEEE Transactions on Evolutionary Computation, Special Issue on Artificial Immune Systems*, volume 6, pages 239–251. IEEE Press, 2002.
- [Hau and Coiera, 1993] D. T. Hau and E. W. Coiera. Learning qualitative models of dynamic systems. *Machine Learning*, 26:177–211, 1993.
- [Kuipers, 1994] Benjamin Kuipers. *Qualitative Reasoning: Modeling and Simulation with Incomplete Knowledge*. MIT Press, Cambridge, MA, 1994.
- [Muggleton, 1996] Stephen Muggleton. Learning from positive data. In *Lecture Notes in AI*, pages 358–376, 1996.
- [Pang and Coghill, 2007] Wei Pang and George M. Coghill. Advanced experiments for learning qualitative compartment models. In *The 21st International Workshop on Qualitative Reasoning*, pages 109–117, Aberystwyth, UK, June 2007.
- [Pang and Coghill, 2010a] Wei Pang and George M. Coghill. Learning qualitative differential equation models: a survey of algorithms and applications. *The Knowledge Engineering Review*, 25(1):69–107, 2010.
- [Pang and Coghill, 2010b] Wei Pang and George M. Coghill. QML-AiNet: An immune-inspired network approach to qualitative model learning. In Emma Hart *et al.*, editor, *LNCS 6209, Proceedings of 9th International Conference on Artificial Immune Systems (ICARIS 2010)*, pages 223–236, Edinburgh, UK, 2010. Springer.
- [Pang and Coghill, 2011] Wei Pang and George M. Coghill. An immune-inspired approach to qualitative system identification of biological pathways. *Natural Computing*, 10(1):189–207, 2011.
- [Ramachandran *et al.*, 1994] S. Ramachandran, R. J. Mooney, and B. J. Kuipers. Learning qualitative models for systems with multiple operating regions. In *the Eighth International Workshop on Qualitative Reasoning about Physical Systems*, pages 213–223. Nara, Japan, June 1994.
- [Say and Kuru, 1996] A. C. Cem Say and Selahattin Kuru. Qualitative system identification: deriving structure from behavior. *Artificial Intelligence*, 83:75–141, 1996.
- [Timmis and Edmonds, 2004] Jon Timmis and C. Edmonds. A comment on opt-AiNet: An immune network algorithm for optimisation. In D. Kalyanmoy, editor, *Genetic and Evolutionary Computation (GECCO 2004), Lecture Notes in Computer Science*, volume 3102, pages 308–317. Springer, 2004.
- [Varšek, 1991] A. Varšek. Qualitative model evolution. In John Mylopoulos and Raymond Reiter, editors, *Proceedings of the Twelfth International Joint Conference on Artificial Intelligence*, pages 1311–1316, Sydney, Australia, 1991. AAAI Press.

A Qualitative Framework for Deriving a Terrain Feature

Shinya ENOMOTO and Kazuko TAKAHASHI

School of Science & Technology,
Kwansei Gakuin University, Japan

aec71668@kwansei.ac.jp ktaka@kwansei.ac.jp

Abstract

This paper proposes a qualitative treatment of a two-dimensional figure with height information. We give a symbolic representation to a terrain, a topographic surface of a landscape, and we can get its abstract feature by reasoning on the representation. A target terrain viewed from above is modeled as a closed rectangle divided into multiple regions. For each pair of adjacent regions, we represent their connection patterns with regard to height. We can derive the relative grade of a slope and/or its direction, as well as the existence of a height gap between regions. We can apply this method for the route finding in a given terrain, considering gradients and gaps. We illustrate an application to an actual landscape.

1 Introduction

Qualitative Spatial Reasoning (QSR) is a method that treats figures or images qualitatively, by extracting the information necessary for a user's purpose [18; 4; 13]. Various formalizations have been proposed to date including RCC [15], 9-intersection model [7], PLCA [20], and so on. It is useful in identifying the feature of a terrain or understanding construction of spatial data at an abstract level. One of natural qualitative representations for a terrain is given using the relationship of attributed regions. Regions such as fields, lakes, buildings or such an area that is affected by a pollution are defined and their relative spatial relationships are expressed using mereological relations, relative size, relative directions, and so on. Assertions such as "The field is tangentially connected to the lake" or "The residential area is in the north of the polluted area" can be handled in these frameworks. However, the answer to the queries regarding height such as "Is there an ascending slope in a specific route?" or "From which area is damaged when a flood occurs?" cannot be derived.

Consider the object shown in Figure 1(a). It is viewed from above and can be represented qualitatively, for example, "Two areas are connected by one line." If we consider the heights of the areas, multiple possible cases are considered. Some of them are shown in Figure 1(b)~(f). They are the shapes of the object viewed from the point VP in Figure 1(a).

We cannot distinguish between these shapes without height information.

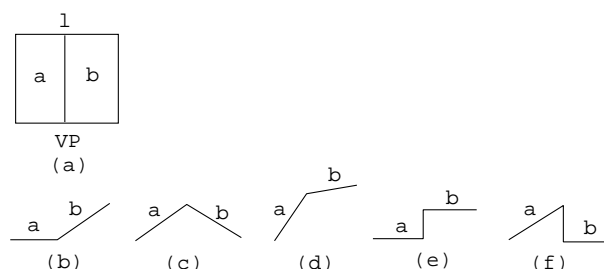

Figure 1: Figures in different heights

Most of works on QSR handle only figures on a two-dimensional (2D) plane. But if we reason about a terrain feature, we have to add some information on relative height to this figure.

One method for handling height information is adding relative height to each region in a 2D plane. But this is not enough since we cannot express the fact that a region is inclined or that there is a height gap between adjacent regions. Another method is adding relative height to several points. However, the representation would be complicated. For a point in a region, it is hard to determine which point should be selected. For a vertex, it is hard to determine which set of target vertices to be compared since most of vertices are contained in multiple regions.

In this paper, we focus on the connection of regions as yet another method. We propose a method such that for each pair of adjacent regions, we represent their connection patterns with regard to height. It can provide information specific to height such as the relative grade of a slope and/or its direction.

We show the outline of the method.

We assume that the target terrain is within a finite range. First, we project the target terrain onto a 2D plane, and divide it into multiple regions by extracting objects such as fields, lakes, buildings and so on. Make a qualitative representation for this 2D figure using PLCA expression [19; 20]. PLCA uses points(P), lines(L), circuits(C) and areas(A) as primitive objects and represents a figure symbolically by the membership relations and connections of these primitive

objects.

Next, we add height information on this expression. Each line is shared by a pair of areas. We express direction of a slope of these areas with respect to the line, that is, ascending, descending, horizontal, or the characteristics of the connection. For example, in Figure 1(c), a is ascending and b is descending with respect to line l . There are two kinds of the connection patterns of the areas, the one by a line (e.g., Figure 1(b)(c)(d)) and the other by a vertical area (e.g., Figure 1(e)(f)). As for the latter, the line observable from above is unique, actually it is a superposition of two lines. These patterns can be distinguished by the representation and in addition, the relative grade of slopes can be derived in some cases.

On this symbolic representation, we can reason about the feature of a path from one area to another, that is, to derive the number of ascending and descending and that of climbing gaps. In this paper, we represent a terrain around our university and present the result of finding the route considering gradients and gaps.

This paper is organized as follows. In section 2, we describe our target terrain and present a description language. In section 3, we show the reasoning on this representation. In section 4, we show an application. In section 5, we compare our work to related works. Finally, in section 6, we present our conclusions.

2 Description Language

2.1 Target terrains

A target terrain viewed from above is modeled as a closed rectangle divided into a finite number of polygons in the following manner: (i) Each polygon corresponds to a plane with a specific height, or a slope in a specific direction with a specific degree of inclination. (ii) Each edge of a polygon is shared at most two other polygons.

Throughout the paper, figures use the rectangle as a polygon to simplify an explanation, but the method is available for any shape.

We also put the following constraints to our target terrain.

- Each edge should be either horizontal, monotonically increasing, or monotonically decreasing in height; that is, it does not have inflection points in its inner part.
- Each area is even; that is, it does not have protuberances or caves in its inner part.
- No area is overhanging.
- Slopes in different directions never cross at their connected lines (Figure 2(a)).
- At least one pair of the opposite edges of an area are both horizontal (Figure 2(b)).

2.2 PLCA expression for a figure in 2D

We proposed PLCA expression [20], the symbolic expression for the projection on a 2D plane.

PLCA comprises four kinds of objects: points, lines, circuits and areas.

A point is defined as a primitive p .

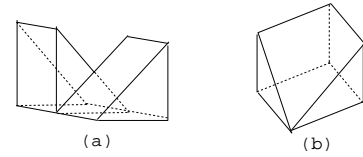

Figure 2: Not-allowed terrains

A line is defined as an object that connects two different points. $l = (p, p')$. We denote $p, p' \in l$. A line has an inherent orientation. When $l = (p, p')$, l^+ and l^- mean (p, p') and (p', p) , respectively. l^* denotes either l^+ or l^- .

A circuit is defined as a sequence of lines. $c = [l_0^*, \dots, l_{n-1}^*]$ where $l_i^* = (p_i, p_{i+1})$ ($0 \leq i \leq n-1$), $l_n = l_0$, $1 \leq n$. We denote $l_i^* \in c$ ($0 \leq i \leq n-1$).

An area is defined as a set of circuits. $a = \{c_0, \dots, c_{n-1}\}$. We denote $c_i \in a$ ($0 \leq i \leq n-1$).

In addition, we assume that there exists a circuit in the outermost side of the figure that is called *outermost*.

Then a figure in 2D plane is expressed as a quadruple (P, L, C, A) , where P, L, C, A are sets of points, lines, circuits including *outermost* and areas together with their relationships.

A PLCA expression $e = \{P, L, C, A\}$ corresponding to Figure 3 is shown below.

$$\begin{aligned}
 e.points &= \{p_0, p_1, p_2, p_3, p_4, p_5\} & l_0.points &= [p_0, p_0] \\
 e.lines &= \{l_0, l_1, l_2, l_3, l_4, l_5, l_6\} & l_1.points &= [p_1, p_2] \\
 e.circuits &= \{c_0, c_1\} & l_2.points &= [p_2, p_3] \\
 e.areas &= \{a_0, a_1\} & l_3.points &= [p_3, p_4] \\
 a_0.circuits &= \{c_0\} & l_4.points &= [p_4, p_5] \\
 a_1.circuits &= \{c_1\} & l_5.points &= [p_5, p_0] \\
 c_0.lines &= [l_0^-, l_5^-, l_4^-, l_6^-] & l_6.points &= [p_1, p_4] \\
 c_1.lines &= [l_1^-, l_6^+, l_3^-, l_2^-] & & \\
 outermost.lines &= [l_0^+, l_1^+, l_2^+, l_3^+, l_4^+, l_5^+] & &
 \end{aligned}$$

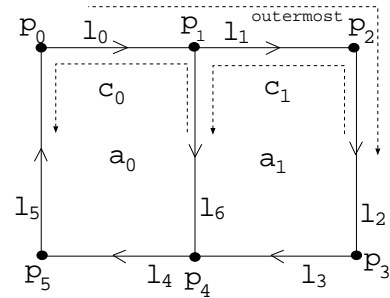

Figure 3: Example of PLCA

Intuitively, PLCA expression can be considered as a doubly-connected edge without coordinates which is used in computational geometry [14]. In doubly-connected edge, there exists only one figure corresponding to a symbolic expression, whereas we can draw infinite number of figures corresponding to a PLCA expression, since it determines no size nor coordinates.

For any line l , there exists circuits c, c' and areas a, b such that $l^+ \in c, c \in a$ and $l^- \in c', c' \in b$. A pair of areas a and b are said to be *adjacent areas* and l is said to be a *c-line* of a and b . The lines l^+ and l^- , denoted by l_a and l_b , are said to be a 's c-line and b 's c-line, respectively, to make it clear which area a line belongs to. For example, in Figure 3, l_6 is a c-line of a_0 and a_1 , l_6^+ and l_6^- are denoted by l_{a_1} and l_{a_0} , respectively.

Originally, a shape of an object is ignored and curved lines are allowed as a PLCA expression. In this paper, we consider a subset of PLCA in which only a straight line is used, a circuit consists of exactly four lines and an area consists of a single circuit.

2.3 Expression for relative height

We add information on height to the PLCA expression, assuming that PLCA expression is already given.

Let F be a target terrain in a 3D space and F_0 be its projection onto a 2D plane. There are two characteristics of an area: plane and slope. A vertical area in F does not appear in F_0 . Thus, some lines and points in F_0 are superpositions of two lines or points, respectively. Superposition means that the objects are in the same position in F_0 but have different heights in F . Consider a terrain in Figure 4(a) whose projection onto a 2D plane is Figure 4(b). A line $l = (p, p')$ in Figure 4(b) is a superposition of l_a and l_b in Figure 4(a). Point p in Figure 4(b) is a superposition of p_a and p_b in Figure 4(a), and point p' in Figure 4(b) is a superposition of p'_a and p'_b in Figure 4(a) where $l_a = (p_a, p'_a)$ and $l_b = (p_b, p'_b)$.

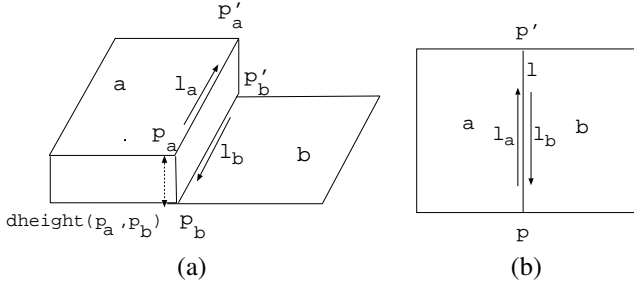

Figure 4: Superposed points and lines

For a point p , $h(p)$ denotes the height of p . For points p_1 and p_2 , $dheight(p_1, p_2)$ denotes a difference of $h(p_1)$ and $h(p_2)$. For example, the dotted line in Figure 4(a) shows $dheight(p_a, p_b)$.

For a line $l = (p_1, p_2)$, if $dheight(p_1, p_2) = 0$, then it is said that l is *horizontal*. In this case, $h(l)$ is defined as $h(p_1)$. If l is not horizontal, $h(l)$ is undefined.

Defintion 1 For a pair of adjacent areas, if c-line is a superposition of two lines, then it is said that the areas are *inclining connected* (i-connected); otherwise, it is said that they are *horizontally connected* (h-connected).

If areas are h-connected, all c-lines are horizontal. If areas are i-connected, at least one of them is not horizontal.

h-connected

The h-connection pattern with regard to height is expressed in the form of $\alpha\mathcal{R}_h\beta$. α and β are pairs of *area* with *height*, where *area* is a corresponding area, and *height* is a relative height of the *area*'s c-line. The value of *height* is either *high*, *low* or *hl*. *high* means that it is higher than the line in the opposite side of *area*. *low* means that it is lower than the line in the opposite side of *area*. And *hl* means all the lines in *area* are the same height. $\mathcal{R}_h = \{<_h, =_h\}$ is a binary relation. It represents a relative height between c-lines of the connected areas.

Defintion 2 For area x , let l_x be an x 's c-line. Then, $c(l_x)$, the qualitative height of l_x in x , is defined as follows:

- $c(l_x) = x_low$ if $\exists l'_x \in x, l'_x \neq l_x$ s.t. $h(l_x) < h(l'_x)$.
- $c(l_x) = x_high$ if $\exists l'_x \in x, l'_x \neq l_x$ s.t. $h(l'_x) < h(l_x)$.
- $c(l_x) = x_hl$ if $\forall l'_x \in x, h(l'_x) = h(l_x)$.

Let l_a and l_b be a 's c-line and b 's c-line, respectively. \mathcal{R}_h is defined as follows.

- $c(l_a) <_h c(l_b)$ if $h(l_a) < h(l_b)$.
- $c(l_a) =_h c(l_b)$ if $h(l_a) = h(l_b)$.

For example, compare the figures in Figure 5. In case (a), since c-line of area a is higher than the line in the opposite side of a , that of b is higher than the line in the opposite side of b , and their heights are equivalent, the connection pattern with regard to height is represented as $a_high =_h b_high$; in case (b), since c-line of area b is equivalent to the line in the opposite side of b , $a_high =_h b_hl$; and in case (c), since c-line of area a is higher than that of b , $b_hl <_h a_high$.

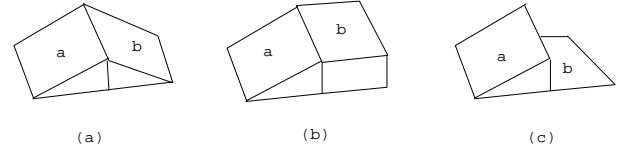

Figure 5: Difference of expressions (h-connected)

i-connected

First, we define *base-point* of a c-line.

For a superposed point p , $f_x(p)$ denotes a point belonging to area x .

Defintion 3 Let $l = (p_1, p_2)$ be a superposed c-line of a and b . A point $dminp$ that satisfies $dheight(f_a(dminp), f_b(dminp)) < dheight(f_a(p'), f_b(p'))$ for all $p' \in l, p' \neq dminp$, is said to be the *base-point* of l .

The base-point of l is either p_1 or p_2 , since the line does not have inflection points in its inner part. The other end of the line is set to be $dmaxp$. $f_x(dminp)$ and $f_x(dmaxp)$ are denoted by $dminp_x$ and $dmaxp_x$, respectively. Note that if a 's c-line and b 's c-line are in parallel, or coincide with each other, their base-points are not defined, since for all $p \in l$, $dheight(f_a(p), f_b(p))$ are equivalent.

The i-connection pattern with regard to height is expressed in the form of $\alpha\mathcal{R}_i\beta$. α and β are pairs of *area* with *height*, where *area* is the corresponding area, and *height* is a relative height of the *area*'s base-point in its c-line. The value of *height* is either *high*, *low*, *hl* or *all*. *high* means that the base-point is higher than the other end point in the c-line. *low* means that it is lower than the other end point in the c-line. *hl* means that the c-line is horizontal. And *all* means the c-line does not have a base-point. $\mathcal{R}_i = \{<_i, \leq_i, =_i\}$ is a binary relation. It represents a relative height between the base-points in the c-lines.

Defintion 4 For an area x , let p_x be x 's $dminp_x$, and l_x be x 's c-line. Then $c(p_x)$ is a connection pattern of an area x with regard to height, and is defined as follows:

- $c(p_x)$ is x_high if $h(dmaxp_x) < h(dminp_x)$.
- $c(p_x)$ is x_low if $h(dminp_x) < h(dmaxp_x)$.
- $c(p_x)$ is x_hl if $h(dminp_x) = h(dmaxp_x)$.
- $c(p_x)$ is x_all otherwise.

Let l_a and l_b be a 's c-line and b 's c-line, respectively. \mathcal{R}_i is defined as follows.

- $c(l_a) <_i c(l_b)$ if both $h(f_a(p_1)) < h(f_b(p_1))$ and $h(f_a(p_2)) < h(f_b(p_2))$ hold.
- $c(l_a) \leq_i c(l_b)$ if both $h(f_a(p_1)) < h(f_b(p_1))$ and $h(f_a(p_2)) = h(f_b(p_2))$ hold, or both $h(f_a(p_1)) = h(f_b(p_1))$ and $h(f_a(p_2)) < h(f_b(p_2))$ hold.
- $c(l_a) =_i c(l_b)$ if $dheight(f_a(p_1), f_b(p_1)) = dheight(f_a(p_2), f_b(p_2))$ holds.

The last one shows the case that a and b are slopes in the same direction with the same degree of inclination.

In Figure 6, (a) is a 3D figure, (b) and (c) are its shapes viewed from above and side, respectively. a and b are adjacent areas, a 's c-line is $l_a = (f_a(p_1), f_a(p_2))$. b 's c-line is $l_b = (f_b(p_1), f_b(p_2))$. In this case, $dminp = p_1$, $dmaxp = p_2$. Since $h(f_a(p_1)) < h(f_b(p_1))$ holds, $c(p_a)$ is a_low . Since $h(f_b(p_1)) < h(f_b(p_2))$ holds, $c(p_b)$ is b_low . And since $h(f_b(p_1)) < h(f_a(p_1))$ and $h(f_b(p_2)) < h(f_a(p_2))$ hold, their i-connection pattern is $b_low <_i a_low$.

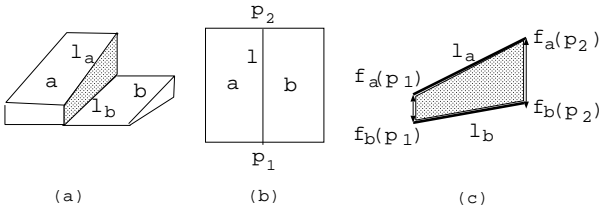

Figure 6: Expression for i-connected pattern

We show other examples of i-connected patterns of areas a and b in Figure 7. These figures show the shape of the connected part from the side viewpoint. The i-connected patterns of a and b are represented as follows: (a) $b_high <_i a_high$, (b) $b_high \leq_i a_hl$, and (c) $b_all <_i a_all$.

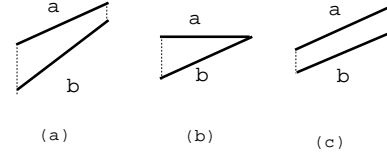

Figure 7: Examples for i-connected patterns

2.4 Validity of expression

Let H be a set of connection patterns for each pair of adjacent areas. There are several necessary conditions that H should fulfill for the existence of the corresponding 3D terrain.

1. For each line, connection patterns with regard to height is uniquely defined.
2. For an area a appearing in H , a_hl does not appear iff a_high or a_low appear.
3. Properties of relative height relation, e.g., transitivity of $<_h$, are not violated.

Consider the following sets of connection patterns. There exists the 3D figure that satisfies H_1 (Figure 8(a)) and H_2 (Figure 8(b)), but there is not for H_3 .

$$\begin{aligned} H_1 &= \{ a_hl =_h b_high, c_hl <_h a_hl, c_hl \leq_i b_low \} \\ H_2 &= \{ a_high =_h b_high, c_hl \leq_i a_low, c_hl \leq_i b_low \} \\ H_3 &= \{ a_hl =_h b_high, c_hl \leq_i a_low, c_hl \leq_i b_low \} \end{aligned}$$

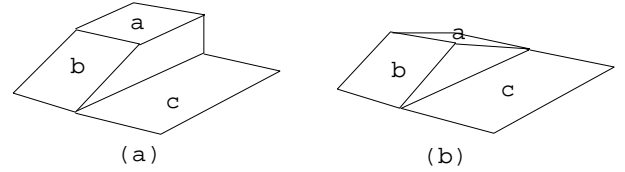

Figure 8: Terrains for given sets of relations of connection patterns

3 Reasoning on degree of slope

We show several reasoning on PLCA with height expression.

Gap between adjacent areas

We can determine whether there is a gap between adjacent areas.

For any pair of adjacent areas a and b , if they are i-connected with a pattern $a_all =_i b_all$, or if they are h-connected with a pattern $a_* =_h b_*$ where $*$ denotes either *high*, *low* or *hl*, then there is no gap between a and b . Otherwise, there is a gap.

For example, in Figure 8(a), there are gaps between areas a and c , b and c , but not between a and b .

Direction of slopes

When areas are h-connected, we can determine the direction of slopes for both areas. On the other hand, when areas are i-connected, we cannot always determine it.

Let x be h-connected with some area, and let $c(l_x)$ be a qualitative height l_x in x . If $c(l_x)$ is x_high , then x is ascending slope towards its c-line. If $c(l_x)$ is x_low , then x is descending slope towards its c-line. If $c(l_x)$ is x_hl , then x is a plane.

Degree of slopes

When areas are h-connected, we cannot determine the degree of slopes. When areas are i-connected, we can determine it when they are inclined in the same direction.

Let a and b be adjacent areas. If the connection pattern with regard to height is $a_all\mathcal{R}_i b_all$, then degrees of inclination of a and b are the same. Otherwise, if $a_high\mathcal{R}_i b_high$, then a is steeper than b ; if $b_low\mathcal{R}_i a_low$, then b is steeper than a .

4 Application

In this section, we show an application of the proposed method for an actual landscape.

4.1 Expression

Figure 9 shows a map of Kobe Sanda Campus of Kwansei Gakuin University, and Figure 10 is its qualitative model which is obtained manually. Kobe Sanda Campus is located on the hill and there are lots of slopes or gaps.

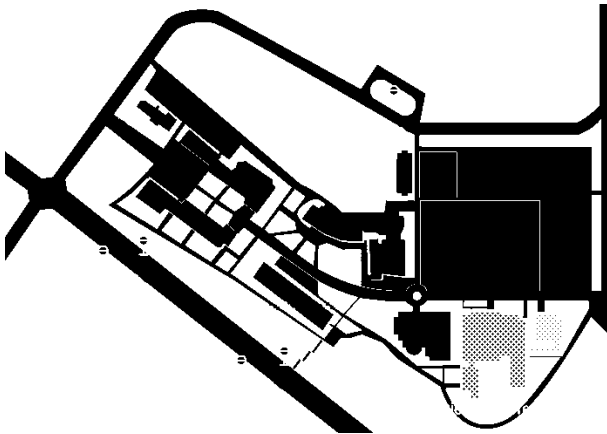

Figure 9: A map of Kobe Sanda Campus

In Figure 10, an arrow indicates the slope in descending direction, a bold line indicates a gap, and an area placed between dotted lines indicates stairways.

For stairways, it is possible to consider them as a sequence of small areas. In this case, we need a refined statement that requires much memory. Here, we use alternative modeling in which the entire stairway is considered a slope. We add an attribute to each area to distinguish a stairway and a real slope. This method can be used not only for stairways, but also areas that we may want to avoid passing, such as an area under construction or a dangerous area.

The followings is a part of elements of the relation of connection patterns.

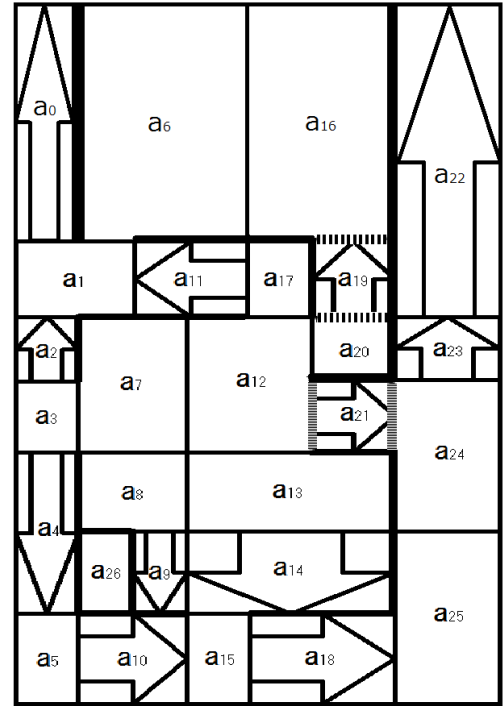

Figure 10: A model for Figure 9

- | | |
|------------------------------------|----------------------------------|
| (1) $a_0_high =_h a_1_hl$. | (2) $a_0_high \leq_i a_6_hl$. |
| (3) $a_1_hl =_h a_6_hl$. | (4) $a_1_hl =_h a_{11_low}$. |
| (5) $a_6_hl \leq_i a_{11_low}$. | (6) $a_1_hl =_h a_2_low$. |
| (7) $a_1_hl <_h a_7_hl$. | (8) $a_2_high =_h a_3_hl$. |
| (9) $a_2_high \leq_i a_7_hl$. | (10) $a_3_hl =_h a_7_hl$. |

They are consistent in the sense that there exists a terrain that satisfies these relationships.

Conversely, we can derive the relation (5) from (3) and (4) if we know that a_6 and a_{11} are i-connected. Similarly, we can derive that a_7 is relatively higher than a_1 , that is, $a_1_hl <_h a_7_hl$ holds from (6),(8) and (10), unless (7) is represented explicitly.

As a result of judging the slopes from this expression, $a_0, a_2, a_4, a_9, a_{10}, a_{11}, a_{14}, a_{18}, a_{19}, a_{21}, a_{22}, a_{23}$ are judged as slopes. This result is consistent with the shape of the actual landscape.

4.2 Route finding

For the PLCA expression with height, we take areas as nodes and lines as edges in a graph, where connection patterns are added to each edge, and apply search algorithms on the graph.

We have implemented the search algorithm and applied it to find a specific route from the entrance of a playground (a_0) to a convenience store (a_{25}) in Figure 10. First, we search for a route that avoids a gap including a stairway as far as possible. The system generates 28 routes that may contain a gap, and 12 of them without a gap. For example, route

(**r2**) $a_0 \rightarrow a_1 \rightarrow a_{11} \rightarrow a_{17} \rightarrow a_{12} \rightarrow a_{21} \rightarrow a_{24} \rightarrow a_{25}$ is a route that passes a stairway a_{21} , whereas route (**r1**) $a_0 \rightarrow a_1 \rightarrow a_{11} \rightarrow a_{17} \rightarrow a_{12} \rightarrow a_{13} \rightarrow a_{14} \rightarrow a_{15} \rightarrow a_{18} \rightarrow a_{25}$ is a route that does not contain a gap. It makes a detour instead of passing a_{21} . (**r1**) is suitable for a user who is searching for a gap-free path.

Next, we search for a route that contains the least number of gradients. Let a, b be adjacent areas. If $a_{.high} =_h b_{.hl}$, then transition from a to b is said to be *ascending*. If $a_{.low} =_h b_{.hl}$, then it is said to be *descending*. Otherwise, it is said to be *flat*. A route is a sequence of these elements. We deduce the number of gradients from the sequence by the algorithm shown below where the variable *count* indicates the number of gradients.

[Algorithm for counting the gradients]

Let a_s be a start area and a_d be a destination area. Let a_0, a_1, \dots, a_n be a route from a_s to a_d without a gap. *check* is a kind of a flag that shows the current state of ascending and descending.

1. Set $i = 0, a_0 = a_s, check = none$ and $count = 0$.
2. If $a_i = a_d$, then terminate.
 Otherwise,
 if transition from a_i to a_{i+1} is ascending
 if $check = down$,
 then increment *count*
 set $check = up$;
 if transition from a_i to a_{i+1} is descending
 if $check = up$,
 then increment *count*
 set $check = down$.
3. Increment i and go back to 2.

As a result, we find that 7 of the 28 routes have three gradients and the others have one. For example, route (**r25**) $a_0 \rightarrow a_1 \rightarrow a_6 \rightarrow a_{16} \rightarrow a_{19} \rightarrow a_{20} \rightarrow a_{12} \rightarrow a_{13} \rightarrow a_8 \rightarrow a_7 \rightarrow a_3 \rightarrow a_4 \rightarrow a_5 \rightarrow a_{10} \rightarrow a_{15} \rightarrow a_{18} \rightarrow a_{25}$ is a route that contains one gradients, whereas route (**r22**) $a_0 \rightarrow a_1 \rightarrow a_2 \rightarrow a_3 \rightarrow a_4 \rightarrow a_5 \rightarrow a_{10} \rightarrow a_{15} \rightarrow a_{14} \rightarrow a_{13} \rightarrow a_8 \rightarrow a_7 \rightarrow a_{12} \rightarrow a_{21} \rightarrow a_{24} \rightarrow a_{25}$ contains three. We conclude that (**r25**) is better than (**r22**) as a less burden route.

5 Discussion

Earlier research on deriving the feature of a terrain is a work by Frank et. al [8]. They formalized using a predicate calculus the extraction of the geomorphographic feature from a set of predicates that expresses the positional relationships between objects such as edges or points. Guilbert proposed a method for extracting and analyzing terrain features from a contour map to give a qualitative description of a landscape [10]. They are not qualitative approaches and numerical data is used to derive the shape of a figure, although the essential idea is similar to ours. Kulik et al. formalized a method of deriving a feature of a terrain from its silhouette obtained by a fixed viewpoint [11]. They define qualitative representation such as ascending or descending for a line segment of a silhouette, and show a method for deriving a shape such as mountain and valley from a sequence of the segments.

They also adopt the relative length of a segment. It is successful for the projection on one-dimension, but two-dimensional case is not handled. On the other hand, we show the treatment of two-dimensional case. Donlon et al. proposed a route-finding system with a concept of "trafficability" [6]. They add attributes such as vegetation and slope to terrains in Geographic Information Systems (GIS) and consider vehicular movements on that terrain depending on these values. Their purpose is to analyze trafficability and they do not adopt an idea of a relative height. On the other hand, our main purpose is to represent abstract features of a landscape with regard to height, and route-finding is one of the applications.

Basically, most studies on QSR have focused on 2D data including the projection of 3D data onto a 2D plane. Few attempts have been made to handle 3D data [1; 16], but they did not aim at the derivation of a feature of a terrain. As for a qualitative navigation, Freksa presented a framework in a 2D plane [9]. He proposed a method for representing an orientation using a reference point and a perspective point, and showed a navigation using their positional relationships. Qualitative treatment of 3D data that is projected onto a 2D plane is used as a robot navigation [17; 22], but symbolic approaches are not taken in these works.

There are lots of works on 3D models for a terrain in the field of GIS [12; 2; 3]. However, they use coordinates and take quantitative approach.

We have provided a method for deriving a feature of a terrain from a set of qualitative representation in a symbolic form.

6 Conclusion

We have presented a qualitative spatial representation based on connection patterns with relative height and reasoning on this representation. This method is a symbolic approach to understand the feature of a terrain. We have also shown the application of this method to route finding with height information of an actual landscape. In this paper, although we adopt a rectangle as a unit area, the method can be applicable to any shape of polygon, which involves triangulated irregular networks (TIN) model or regular square grid as a surface model.

This work is ongoing and there are lots of issues to be discussed. Among them, the most important ones that we currently think are the following three points.

1. To determine the method or rules to extract a terrain feature in a higher level, such as mountain and valley from the set of relations of connection patterns.
2. To find the condition that a set of relations of connection patterns should satisfy so that there exists a corresponding 3D figure.
3. To find a class of terrains that can be handled by this method, and how far the method can be extended.

Acknowledgments

This work is supported by JSPS KAKENHI Grant No. 25330274.

References

- [1] J. Albath, J. L. Leopold, C. L. Sabharwal, and K. Perry, 'Efficient reasoning with RCC-3D', in *Proceedings of Knowledge Science, Engineering and Management 2010*, pp. 470–481. Springer, (2010).
- [2] B. Brugman, T. Tijssen and P. van Oosterom, 'Validating a 3D topological structure of a 3D space partition,' AGILE Conferce pp.359-378 (2011).
- [3] R. Billen and S.Zlatanova, '3D spatial relationships model: a useful concept for 3D cadastre?' in *Computers, Environment and Urban Systems* **27**(4): 411–425, (2003).
- [4] A. G. Cohn and S. M. Hazarika, 'Qualitative spatial representation and reasoning: An overview.', *Fundamental Informaticae*, **46**(1-1), 1–29, (2001).
- [5] A. Cohn and J. Renz, 'Qualitative spatial representation and reasoning', *Handbook of Knowledge Representation*, Chapt. 13, pp. 551-596, F. van Harmelen, V. Lifschitz, and B. Porter, Eds., Elsevier, (2008).
- [6] CPT J. J. Donlon and K. D. Forbus, 'Using a Geographic Information System for Qualitative Spatial Reasoning about Trafficability' in *Proceedings of 13th International Workshop on Qualitative Reasoning*, (1999).
- [7] M. Egenhofer and J. Herring: 'Categorizing binary topological relations between regions, Lines, and Points in Geographic Databases', in *Department of Surveying Engineering*, University of Maine, (1990).
- [8] A. U.Frank, B. Palmer and V. B. Robinson, 'Formal methods for accurate definitions of some fundamental terms in physical geography', in *Proceedings of Second International Symposium on Spatial Data Handling*, pp.583-599, (1986).
- [9] C. Freksa, 'Using orientation information for qualitative spatial reasoning' in *Theories and methods of spatio-temporal reasoning in geographic space*, pp.162 - 178, Springer, (1992).
- [10] E. Guilbert, 'Multi-level representation of terrain features on a contour map' in *GeoInformatica*, **17**:301-324, (2013).
- [11] L. Kulik and M. J. Egenhofer, 'Linearized terrain: languages for silhouette representations' in *Spatial Information Theory (COSIT2003)*, pp. 118-135, (2003).
- [12] C. Lemmen and P. van Oosterom, '3D cadastres,' in *Computers, Environment and Urban Systems*, **27**(4): 337-343 (2003).
- [13] G. Ligozat, *Qualitative Spatial and Temporal Reasoning*, Wiley, (2011).
- [14] M. Overmars, M. de Berg, M. van Kreveld and O. Schwarzkopf. *Computational Geometry*, Springer-Verlag, (1997).
- [15] D. A. Randell, Z. Cui, and A. G. Cohn, 'A spatial logic based on regions and connection', in *Proceedings of the Third International Conference on Principles of Knowledge Representation and Reasoning*, pp. 165–176. Morgan Kaufmann Publishers, (1992).
- [16] C. Sabharwal, J. L. Leopold, and N. Eloë, 'A more expressive 3D region connection calculus', in *Proceedings of the 2011 International Workshop on Visual Languages and Computing*, pp. 307–311, (2011).
- [17] N. M. Sgourosa, 'Qualitative navigation for mobile robots in indoor environments,' in *Applied Artificial Intelligence: An International Journal*, **15**(3):237-251, (2001).
- [18] O. Stock, *Spatial and Temporal Reasoning*, Kluwer Academic Press, (1997).
- [19] K. Takahashi, T. Sumitomo and I. Takeuti. 'On embedding a qualitative representation in a two-dimensional plane,' *Spatial Cognition and Computation*, **8**(1-2):4-26, (2008).
- [20] K. Takahashi, 'PLCA: a framework for qualitative spatial reasoning based on connection patterns of regions,' *Qualitative Spatio-Temporal Representation and Reasoning: Trends and Future Directions*, S.Hazarika(ed.), Chapt 2, pp.63-96, IGI Publishers, (2012).
- [21] M. Westphal, S. Wöflf, B. Nebel and J. Renz, 'On qualitative route descriptions: representation and computational complexity,' in *Proceedings of the twenty-second International Joint Conference on Artificial Intelligence*, pp.1120-1125, (2011).
- [22] D. Wolter, F. Dylla and A. Kreutzmann, 'Rule-compliant navigation with qualitative spatial reasoning,' in *Proceedings of the 4th International Robotic Sailing Conference.*, Springer, (2011).

Qualitative knowledge and memories within a creative decisionmaking process: A case-study in architecture planning and design

Dino Borri, Domenico Camarda, Rossella Stufano
Politecnico di Bari, Italy
d.camarda@poliba.it

Abstract

Human agents conceptualize, design and organize spaces for human organizations by using numerous routine and non-routine cognitive processes [Schön, 1983]. Automated reasoning and design agents still provide only bad copies of human performances [Hofstadter, 1995]. Here, creativity is postulated as a non-routine sophisticated human cognitive function, a conscious and intentional process for redefining agents' situations in the world. Even if the concept of creativity remains controversial, cognitive scientists increasingly consider creativity as a specific part of the ordinary cognitive equipment of the human agent, usable in certain situations, not confined to exceptional human agents [Bink and Marsh, 2000; Weisberg, 1993]. In this context, it seems worthwhile adding spatial domain to the other domains of creativity studied in cognitive science. We assume that space organizing can be fruitfully analyzed and modelled by paying attention to both routine and non-routine (creative) cognitive functions [Barkowsky *et al.*, 2007]. Civil architecture is a relevant domain of spatial knowledge and action, and of course of spatial organization. The present paper looks at creativity in civil architecture, by observing experimental ad-hoc design sessions carried out by a professional architect. A cognition-based discussion provides suggestions on the critical role of spatial memories in enhancing creativity.

1 Introduction

We explored creativity, its characteristics, its role within the design process in architecture. We analyzed creativity according to the cognitivist approach using the tools of knowledge engineering and scientific literature related to Artificial Intelligence.

The organization of space is an essential component of the space capabilities of human agents. It is a fact that human agents are able to conceptualize space first, and then to design and organize them.

We intend to add the space domain to other domains discussed about creativity in typical cognitive science. In

particular in our analysis the concepts of the comprehension of space and spatial organization have been studied with reference to creative and non-routine cognitive functions according the perspective of modeling.

In the cognitive environments of artificial intelligence research [Boden, 2004; Hofstadter, 1995; Johnson-Laird, 1988; Minsky, 2006], creativity is seen as a normal function of the human intellect, to be analyzed according to a strict theoretical and experimental scientific investigation.

The modeling and design of artificial space environments, cities and urban architectures in particular, must take into account highly heterogeneous information sources

Beyond quantitative and qualitative spatial constraints, there are relations and conceptualizations depending on function and being meanwhile abstract, that need to be considered in data relations and in agents' decisions. Through the use of a modular ontology and an approach based on e-connections theory, the research project aims at drawing on different domains connected to spatial modeling and designing activity (formal rationalities, e.g. geometries, and informal rationalities, such as emotions) [Bhatt *et al.*, 2011; Minsky, 2006]. This is done with the aim of modeling more efficiently and effectively databases and relations needed to optimize the processes of simulation of operational spatial environments' analysis and transformation [Borri *et al.*, 2012].

Within this general framework, the paper offers a preliminary and rather qualitative set of comments basing on some pilot studies. It is organized as follows. After this introduction, a second session follows, arguing on the concept of creativity with its connections to cognition and decision, in an evolutionary perspective. The third session shows and discusses an experimental session involving an architect during his carrying out an ad-hoc design task. Brief considerations conclude the work.

2 Knowledge, decision, creativity

Within the science of complex systems, the real environment is one of the most representative examples of actual complexity. In fact, real environment represents an open dynamical system, with manifold variables, sensitive to internal as well as external contextual stimuli. Planning efforts traditionally build rational, optimal action lines

starting from initial states (objectives, values) toward final states (solutions) through a decision-feedback process [Blum and Furst, 1997; Faludi, 1987]. Yet an open dynamical system such as a real (natural, social, behavioural) environment does not fulfill the rational requirements of complete knowledge and information [Arrow, 1963]. In this concern, it is well known Simon's proposal of achieving "satisficing", rather than optimal solutions to complex problems, and this stance is contextually suitable to environmental decision problems [Simon, 1945].

A rational decision process bounded by cognitive constraints has driven the increasing consideration of knowledge and information issues as critical for effective decisionmaking. Particularly, the need of including informal forms of knowledge has raised the interest of planners and managers, as well as researchers. Social scientists and public managers have been long interested in the informal knowledge raised from community participation to planning processes [Forester, 1999; Sandercock, 1998]. Also, tacit and implicit knowledge has been investigated, in the attempt of grasping perceptual and/or emotional characters of daily life environments [Borri *et al.*, 2010; Damasio, 1999; Kessell and Tversky, 2011]. In both cases, qualitative elements come at the forefront of decisionmaking, involving informal, non-quantitative metrics in the generation of knowledge and information. They coexist with the formal languages of rational metrics and quantitative variables, and the whole set of elements, variables and interactions are expected to allow the representation of the environment for an informed decision process.

This is obviously far from being easy. Many difficulties arise within knowledge-raising processes, both in finding/designing proper environments and in managing the qualitative and quantitative forms of knowledge raised in planning processes [Freksa *et al.*, 2008; Khakee *et al.*, 2000]. Ad-hoc models and system architectures are then increasingly studied and set up to handle such complexities, supporting informed decisions. When collaborative platforms are laid out to enhance cognitive interactions among agents, then an enriched content is grasped including spoken, written, graphical, gestural, behavioural languages [Al-Kodmany, 2002; Feyereisen, 2000; Wooldridge and Veloso, 1999]. Agents' approach to enriched language is highly dependent on single personalities, expertises and cultural backgrounds, memories of past interactions with other human/artificial agents and/or spatial contexts. It does affect the very structure of each knowledge agent as a cognitive frame [Shakun, 1996]. As a matter of facts, the cognitive process ends up playing a critical role in spatial contexts, deeply affecting agents' perception, representation, association abilities.

In this context, the design process in spatial environments is a chain of complex decisions. In it, abilities play a fundamental role, enhancing, boosting or hindering the design effort. It has been long argued that planners and expert designers should have a fair amount of intuition, as well as visionary and abstraction abilities, to carry out

spatial plans. In particular, architecture design is a task in which spatial decisions concerning shapes, functions and aesthetics are claimed to be harmoniously and effectively mixed up by a great amount of creativity [Bink and Marsh, 2000; Healey, 2004].

As a matter of facts, an architect is often considered as a quintessential creative, similarly to a painting or musical artist. Even more, his creative abilities are popularly seen as innate, i.e., irreplicable and difficult to be taught, enhanced or even calibrated and/or modified. Domain literature has historically approved such stance, often with descriptive rather than explorative scientific approach [Sharp, 2002]. Yet psychological and cognitive studies suggest that creativity is largely a cognitive process. In it, an agent develops analogies, associations, contaminations of abstraction levels, memories and technicalities toward the final artwork [MacKinnon, 1962; Poincare, 1908, p.56; Zumthor, 1998]. Indeed, managing memories is a fundamental prerogative in professionals and practitioners, when reflecting on their actions or picking up ad-hoc memories toward creative solutions to spatial problems [Hirschman, 1958; Schön, 1983].

The case of architecture plan and design seems to be particularly suitable in this context, because of an inherent correspondence among elements as memories and their spatial representation. Concepts and relations in spatial cognition are critical features for spatial representation in design processes. This involves that a formalization of cognitive conceptualizations would increase the potentials of formal models to support and enhance spatial creativity. Such formal conceptualization of spatial frames, elements and relations is explored by cognitive science through an ontological and spatial-based approach [Anderson, 1983; Falquet *et al.*, 2011; Hofstadter, 1995].

The research activity framing the present study is just aimed at exploring ontological models of spatial-cognition activity in planning and design creativity. In this context, both single-agent and (less frequent) multiagent designing tasks are a breeding ground toward the collection of spatial ontologies and eventually the setting up of knowledge-managing decision support systems.

A multiagent approach to architecture drawing was developed in previous experimental sessions, basically highlighting the importance of mutual stimuli to participating architects, in a learning-by-doing collaborative fashion [Borri *et al.*, 2010]. The present paper is instead oriented to scan the work of a single expert, particularly looking at the role of her/his qualified knowledge and memories during the drawing process. A number of outcomes are expected from such research effort, both substantial and methodological, toward understanding the extent to which design creativity is dependent on, or at least influenced by, the normal featuring abilities of an architect agent's expertise.

An experimental case study

We carried out an experimental set of pilot studies about issues relating to creative knowledge of expert agents during

their designing. In the experiment carried out and described below we have only observed the architect, Vincenzo D'Alba, in front of a blank sheet of paper, and with a design theme that was made known only at the time of the incipit of the experimental design. This experiment had six different design moments and six different interview moments consequently.

The reference is to the methodological framework proposed by Buchanan as early as the late 1980s for the elicitation of expert knowledge in the field of artificial intelligence through 'sharing observation' (Buchanan, 1989). This method requires a silent coaching or at most a 'light' interaction by a 'knowledge engineer'.

We have made a video for each designing session. The zenithal recovery allows us to observe like a distant and objective eye the design process, and gives us material to study the different dynamics that the project develops.

The purpose of the experiment was to create a simulation of the project, and identify what are the geometries and memories references. We chose a design theme that was architecturally significant and also coherent with an urban planning approach, concerning to shapes, materials, geometries, et cetera.

This was the urban door theoretical project genesis (Fig.1).

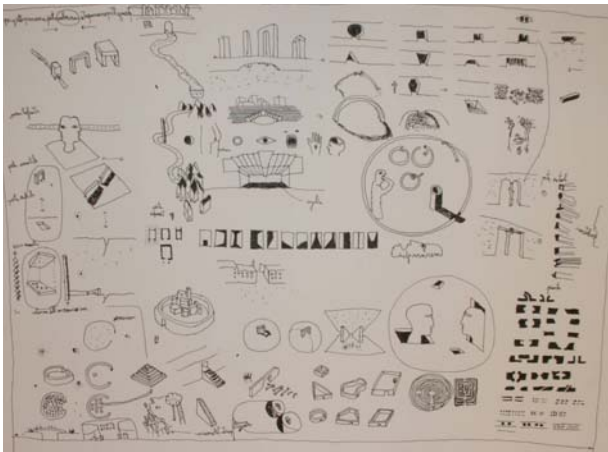

Figure 1. The first drawing session

We have analyzed the architect design process according to five main categories: (i) size, (ii) the form, (iii) the geometry, (iv) the value in memory, (v) the logical groups.

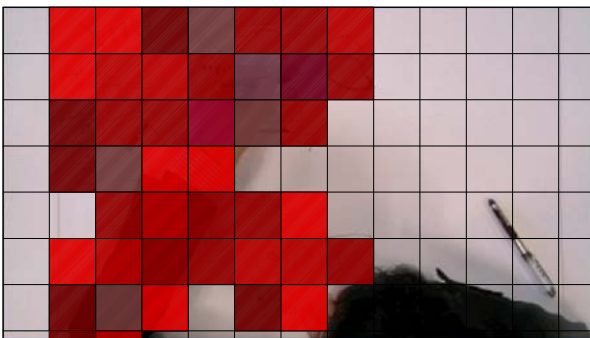

Figure 2. Applying a grid

This approach allowed us to observe the approach to the project, the sheet space, the time taken to draw the various elements that gradually changed and evolved towards greater size of the elements and a different time engaged on an equal area.

Applying a grid on the table whose minimum unit defines the unit of reference surface we can: (i) analyze how much time or how many times the architect expresses the same unit area, (ii) what moves, what areas the architect uses in his movements through the sheet (Fig. 2).

The other graphical interpretation concerns the size and the arrangements in the use of paper space according not to time but to the distribution in time, e.g., in the evolution of the session throughout the surface of the paper, in to the size and distribution of the elements, their being more or less scattered or their aggregation in logical groups more or less complex.

We have identified a measurement unit calibrated to the elements of the table, the minimum unit corresponding to the size of the first gesture, the first path object.

It is interesting to compare the first and the last table (Fig. 3), observing the substantial difference in the size of the objects and their distribution in sheet space.

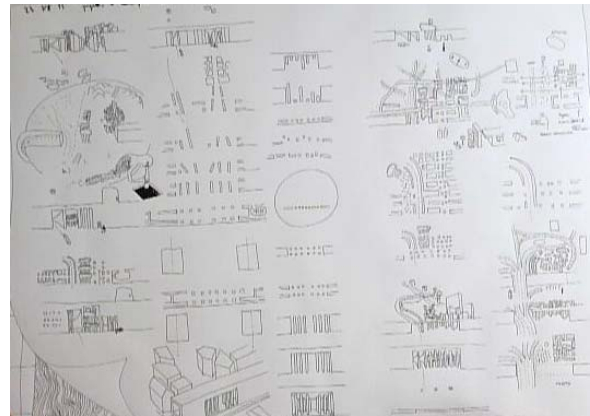

Figure 3. The last drawing session

Substantially, going from the first to the last session, there are some interesting results to be noticed (Fig. 4):

- Signs become larger
- Sign become more defined
- Groups are less scattered
- Groups are more aligned on regular grids
- Signs and drawings are more thematically coherent to one another
- The evolution of signs is far less fragmented and more continuously put down
- The last session shows possible follow-ups beyond the mere door theme.
- Logical groups are drawn out in less time.
- There is a more intentional approach in the last drawing as compared to the first drawing: the first drawing is more explorative.



Figure 4. Logical groups in the first and last drawing: similarities and differences

As a whole, the decision process behind the experimental sessions differs significantly throughout the sessions. Memories from the first drawings emerge in the last part of the series and provides elements to accomplish parts of the given tasks.

Discussion and conclusions

An increasing number of cognitive scientists does consider creativity as a normal cognition ability, nowadays. That appears, in fact, as a human agents' prerogative which can be started off in particular occasions. This actually challenges the traditional concept of creativity as an exceptional patrimony of talented agents [Bink and Marsh, 2000; Ward *et al.*, 1997; Weisberg, 1993]. Yet it still appears as made of a wicked bunch of capabilities and skills that is far from being emulated by automatic systems. In fact, human cognition features and behaviours -such as analogical and abstracting abilities- are mostly irreplicable by computer-based reasoning [Hofstadter, 1995]. Relevant cognitive functions in humans are therefore significantly non-routine, in that showing an evidence of creativity [Bink and Marsh, 2000].

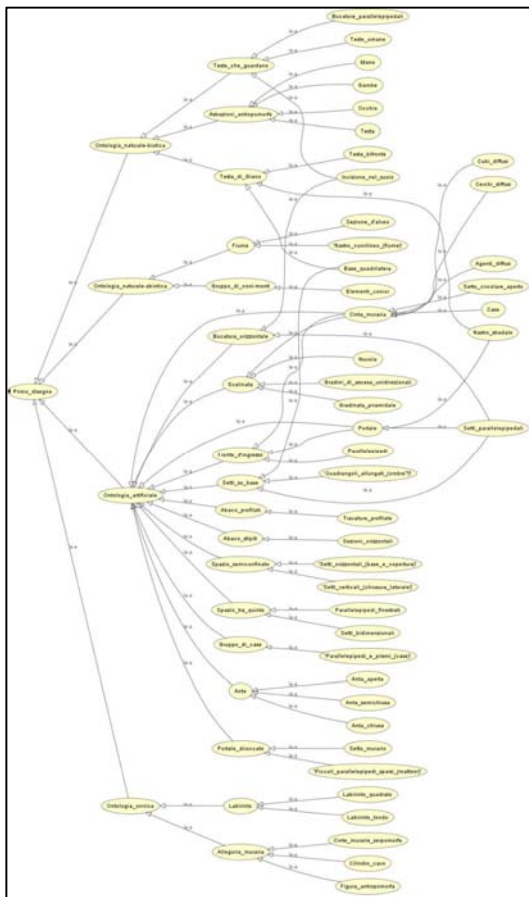

Figure 5. Ontological representation using Protégé

Starting from this stance, the paper has tried to offer a preliminary and rather qualitative set of analyses and perspective comments. Its basic hypothesis is that the dealing with both routine and non-routine cognitive functions would allow the setting up of models of spatial organization creativity. The pilot experimental sessions developed above have given intriguing arguments and outcomes. In particular, considered the experiment as a decision path of a spatial-cognition organization activity, it seems to allow the raising out of memories from knowledge databases toward the working out of new connections, concordances, correlations and associations of concepts as basis for the new original artwork. This kind of framework clearly recalls an ontological layout behind the organization of cognitive concepts and relations. Therefore, the research has been focused on an analyzing spatial cognition ontologies, by using the ad-hoc Protégé software. In particular, an investigation is being carried out toward the building out and use of queries to manage the embedded knowledge database. Such queries are set up and used with the aim of understanding the extent to which the decision process enhancing the spatial design task do actually rely on a cognition database of memory ontologies (figure 5).

As a matter of facts, if memories prove to be essential for an effective carrying out of designing tasks creatively, then this may be useful in a perspective of allowing the augmenting of personal memory management abilities by an ad-hoc tool. The structure of the memory flow of cognitions plays a critical role in this concern. For example, a missing piece in the usual architect's sequential-based organization of memories may hamper the completion of a design task. Yet in that case the structure of memories can turn from sequential to frame-based, by adding the very situation with memorized details, relations, concepts, issues, so achieving an ontological representation of the context able to make up for the missing link and enhance the designing task again. The extent to which the decision support tool is able to manage dynamically sequences as well as frames may represent its degree of effectiveness in enhancing creativity. The architect's professional experience and skill, as well as her/his personal and educational history may be largely framed in an evolutionary ontology of her/his cognitive database, so preventing significant memories from being discarded because of uncertain or missing links.

Admittedly, the findings of this paper are to be considered preliminary and based on pilot studies that are rather qualitative. Yet the experimentation suggests that creativity is a result of an ordinary cognitive activity of a skilled agent, able to develop intentional memory associations, rather than to exert mysterious innate intuitions.

Within this conceptual framework, some of the initial assumption of the study seem to be somehow confirmed. This is rather encouraging toward the setting up of formal design models of architectural composition. In particular, a fairly realistic objective for the next future could be the development of a knowledge management system aimed at supporting and enhancing creative efforts in urban architecture and planning. To this aim most of the spatial-

cognition researches of a joint initiative between Bremen and Bari (Italy) universities will be oriented in the future.

References

- [Al-Kodmany, 2002] Kheir Al-Kodmany. Visualization tools and methods in community planning: From freehand sketches to virtual reality, *Journal of Planning Literature*, 17(2):189-211, 2002.
- [Anderson, 1983] J. R. Anderson. *The Architecture of Cognition*. Harvard University Press, Cambridge MA, 1983.
- [Arrow, 1963] K. J. Arrow. *Social Choice and Individual Values*. Wiley, New York, 1963.
- [Barkowsky et al., 2007] T. Barkowsky, M. Knauff, G. Ligozat and D. R. Montello. *Spatial Cognition: Reasoning, Action, Interaction*. Springer, Berlin, 2007.
- [Bhatt et al., 2011] Mehul Bhatt, Joana Hois and Oliver Kutz. Ontological modelling of form and function for architectural design, *Applied Ontology*, 1:1-32, 2011.
- [Bink and Marsh, 2000] M. L. Bink and R. L. Marsh. Cognitive regularities in creative activity, *Review of General Psychology*, 4(1):59-78, 2000.
- [Blum and Furst, 1997] Avrim Blum and Merrick Furst. Fast planning through planning graph analysis, *Artificial Intelligence*, 90:281-300, 1997.
- [Boden, 2004] M. Boden. *The Creative Mind: Myths and Mechanisms*. Routledge, London, 2004.
- [Borri et al., 2010] Dino Borri, Domenico Camarda and Rossella Stufano. Memory and creativity in cooperative vs. non cooperative spatial planning and architecture, *Lecture Notes in Computer Science*, 6240:56-65, 2010.
- [Borri et al., 2012] Dino Borri, Domenico Camarda and Rossella Stufano. Spatial primitives and knowledge organization in urban planning and architecture. *11th International Conference on Design and Decision Support Systems in Architecture and Urban Planning (DDSS 2012)*. Eindhoven, 2012.
- [Damasio, 1999] A. R. Damasio. *The Feeling of What Happens*. Harvest Books, New York, 1999.
- [Falquet et al., 2011] G. Falquet, C. Metral, J. Teller and C. Tweed. *Ontologies in Urban Development Projects*. Springer London, Limited, 2011.
- [Faludi, 1987] Andreas Faludi. *A Decision-centred View of Environmental Planning*. Pergamon, Oxford, 1987.
- [Feyereisen, 2000] Pierre Feyereisen. Representational Gestures as Actions in Space: Propositions for a Research Program, *Brain and Cognition*, 42(1):149-152, 2000.
- [Forester, 1999] J. Forester. *The Deliberative Practitioner: Encouraging Participatory Planning Processes*. MIT Press, Cambridge MA, 1999.
- [Freksa et al., 2008] C. Freksa, N.S. Newcombe, P. Gardenfors and S. Wolf (eds.). *Spatial Cognition VI. Learning, Reasoning, and Talking about Space*. Springer, Berlin, 2008.
- [Healey, 2004] Patsy Healey. Creativity and urban governance, *Policy Studies*, 25(2):87-102, 2004.
- [Hirschman, 1958] A.O. Hirschman. *The Strategy of Economic Development*. Yale University Press, New Haven, 1958.
- [Hofstadter, 1995] D. R. Hofstadter. *Fluid Concepts and Creative Analogies*. Basic Books, New York, 1995.
- [Johnson-Laird, 1988] P.N. Johnson-Laird. *The Computer and the Mind: An Introduction to Cognitive Science*. Harvard University Press, Cambridge, 1988.
- [Kessell and Tversky, 2011] Angela Kessell and Barbara Tversky. Visualizing space, time, and agents: production, performance, and preference, *Cognitive Processing*, 12(1):43-52, 2011.
- [Khakee et al., 2000] A. Khakee, A. Barbanente and D. Borri. Expert and experiential knowledge in planning, *Journal of the Operational Research Society*, 51(7):776-788, 2000.
- [MacKinnon, 1962] Donald W MacKinnon. The nature and nurture of creative talent, *American psychologist*, 17(7):484, 1962.
- [Minsky, 2006] M. L. Minsky. *The Emotion Machine: Commonsense Thinking, Artificial Intelligence, and the Future of the Human Mind*. New York, Simon and Schuster, 2006.
- [Poincare, 1908] Henry Poincare. *Science et Methode*. Ernest Flammarion, Paris, 1908.
- [Sandercock, 1998] Leonie Sandercock. *Towards Cosmopolis: Planning for Multicultural Cities*. Wiley, Chichester, 1998.
- [Schön, 1983] D. A. Schön. *The Reflexive Practitioner*. New York: Basic Books, 1983.
- [Shakun, 1996] M. Shakun (ed.) *Negotiation Processes: Modeling Frameworks and Information Technology*. Kluwer, Boston, MA, 1996.
- [Sharp, 2002] D. Sharp. *Twentieth Century Architecture: A Visual History*. Images Publishing, 2002.
- [Simon, 1945] H.A. Simon. *Administrative Behavior: A Study of Decision-making Processes in Administrative Organization*. Macmillan, 1945.
- [Ward et al., 1997] T. B. Ward, S. M. Smith and J. Vaid (eds.). *An Investigation of Conceptual Structures and Processes*. American Psychological Association, Washington, D.C, 1997.
- [Weisberg, 1993] Robert W. Weisberg. *Creativity: Beyond the Myth of Genius*. W.H. Freeman & Company, New York, 1993.
- [Wooldridge and Veloso, 1999] M. Wooldridge and M. Veloso (eds.). *Artificial Intelligence Today: Recent Trends and Developments*. Springer, Heidelberg, 1999.
- [Zumthor, 1998] P. Zumthor. *Thinking Architecture*. Zumthor and Muller Publishers, Baden, 1998.

Adding Perspectival Location to a Mereology-Topological Theory of Spatial Representation

Marion Haemmerli

University of Lausanne

Switzerland

marion.haemmerli@unil.ch

Abstract

Perspectival location is location expressed by projective terms such as 'in front of', 'behind', 'left', etc. Perspectival location has been extensively studied in the context of orientation calculi for qualitative spatial reasoning. However, perspectival location has not been integrated so far in an ontologically motivated qualitative theory of spatial representation based on mereology-topology. In this paper, we analyse the geometrical and ontological core features of perspectival location as they have appeared in various orientation calculi to formulate the principal requirements for a mereology-topological theory of spatial representation that extends to perspectival location.

1 Introduction

Perspectival location is location expressed by projective terms such as 'in front of', 'behind', 'to the left of', 'to the right of', and all their combinations and variants¹. The concept of perspectival location is different from the spatial concepts expressed by such terms as 'part of', 'connected with' or 'located at', which are all "detached" or "absolute" in that they are independent of contextual information [Casati and Varzi, 1999]. 'Located at' refers to location as a relation between an entity and its *place*, a place being understood as a region of space [Casati and Varzi, 1997; Parsons, 2006].

Perspectival location, in contrast, is undetached as it involves a contextual element in a particular way. We cannot sensibly determine the truth-value of the proposition expressed by 'The old pine tree is in front of the house' unless we specify *with respect to what* it is that the old pine tree is in front of the house. Sometimes the contextual element is made explicit. We say: 'The bike is to the left of the tree *from your point of view*'. Points of view, or frames of reference, whatever they are, seem to be necessary for an appropriate analysis of the truth values of propositions expressing perspectival location.

¹For the purpose of simplicity, we restrict our attention to the two-dimensional case in this paper, although our results apply to the general case.

At the same time, qualitative theories of spatial representation based on a mereology-topological core structure have thus far been restricted to absolute spatial concepts. Such theories are interesting insofar as they are conceived to meet at least two desiderata: First, they should reflect the geometrical structure of the common-sense world of everyday action and cognition. And second they should be accurate with respect to the ontological assumptions about this common-sense world.

The aim of this article is to go some way towards integrating perspectival location into a qualitative theory of spatial representation based on mereology-topology. Relying on previous work from various disciplines, we will examine geometrical and ontological features of perspectival location to see how it can be added to a mereology-topological theory of spatial representation.

The paper is structured as follows. In section 2, we will discuss two issues that one has to consider when integrating perspectival location into a mereology-topological theory of spatial representation. In section 3, we will then present how one may address these issues in such a way as to add perspectival location to a theory of spatial representation in a geometrically and ontologically meaningful way. In the last section we conclude with open questions and future work.

2 Two Observations

Mereology-topology is a first-order axiomatised theory that studies part-whole structures and structures of topological connection. It often comprises the two primitive binary predicates P for parthood and C for topological connection. If mereology-topology is supplemented with a theory of absolute location, it further contains a primitive binary predicate L for exact location. Exact location is the relation between an entity and the region of space at which it is exactly located.

This short characterisation of mereology-topology and location theory suffices to raise a question about a possible extension to perspectival location. Absolute location is location *at some place*, where a place is often understood as a spatial region. Perspectival location being a kind of *location*, we may naturally ask whether the locative concept at play is again location *at a place*. Many orientation calculi make use of the concept of location in a region to account for perspectival location [Eschenbach, 1999; Clementini and Billen, 2006]. We will critically assess whether this strategy can be successful.

Another question naturally comes up if we are to integrate perspectival location into a first-order formal theory of spatial representation. This second question regards the nature of those things referred to by projective terms. Against a wide-spread (although seldom articulated) *ambiguity thesis*, projective terms are ambiguous in that they refer sometimes to binary and sometimes to ternary relations. We will argue that the ambiguity thesis is false and that projective terms are best understood as unambiguously referring to ternary relations.

2.1 It's not Location at a Region

Absolute location theories understand location as a relation between an entity and a region (or a place). An entity is exactly located at the volume of space it "exactly cuts out" [Casati and Varzi, 1997] of the air at a given moment of time; it is entirely located in a region at a part of which it is exactly located, and it is generically located at a region at a part of which a part of the entity is exactly located [Casati and Varzi, 1997]. Insofar as perspectival locative statements predict a location relation from one or more entities, it is natural to ask whether the locative concept at play is again *location at a region*.

Perspectival locative statements come in natural language in a variety of different shapes. They sometimes come in relational form either as binary or as ternary relations. We say: 'The old pine tree is in front of the house', or 'The bike is to the left of the house from my point of view'. But we also use projective terms in adverbial, nominal and adjectival shape. We say: 'Go left!', 'Look at your left!', 'His room is the upper left of the house'.

These natural language statements are compatible with two competing analyses of perspectival location. On the first analysis, perspectival location is location at a region. To be to the left of the house is to be entirely located in some region, the region 'left of the house'. The relevant region is defined by geometrical means and the locative concept at play is location at a region. This analysis is particularly apt to account for nominal or adverbial perspectival statements, as they explicitly contain perspectival location indications as indications of a place. It underlies most prominent orientation calculi [Frank, 1991; Eschenbach, 1999; Renz and Mitra, 2004; Clementini and Billen, 2006]².

On an alternative analysis, 'front', 'right', 'left' express genuine relations that cannot be reduced to location at a region. They may be reduced to other geometrical relations, but the locative concept at play cannot be location at a region. This second analysis, although less well known, is supported by a straightforward argument about natural language use of projective terms: To understand left, right, front, etc., in terms of jointly exhaustive and pairwise disjoint acceptance areas [Clementini and Billen, 2006] cannot do justice to the various constellations we can express with the help of these relations.

²Of course not all authors use the same terminology. Qualitative projection- and cone-based calculi typically work with qualitative directions. Yet qualitative directions are modelled as regions of space and perspectival location is understood as location within a qualitatively defined zone corresponding to a qualitative direction.

Our contention is that – given basic common-sensical intuitions – the white rectangle on the left in figure 1 should count as being in front of P . Yet if we are to understand the front relation in terms of location within some delimited acceptance area, then we cannot count the white rectangle as in front of P without counting the dark spot as in front of P . A potential way out may be to introduce finer-grained location predicates and to say that the white rectangle is generically in front of P , although not entirely. Yet on this approach we won't be able any longer to distinguish the relation between P and the white rectangle on the one hand, and P and the shaded grey rectangle in the figure to the right on the other. Common sense seems to tell us that they are not both in front of P *in the same sense*, though.

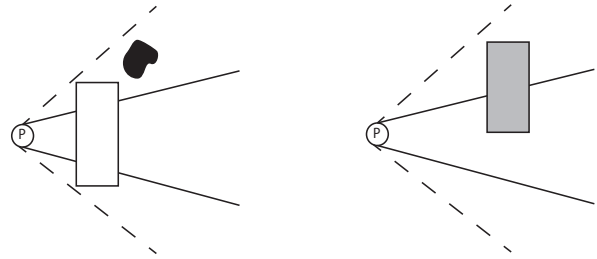

Figure 1: If front of P is to be understood as a region, we cannot count the white rectangle as in front unless we also count the black spot as in front. Yet intuitively the white rectangle should count as in front of P – in a stronger sense than the shaded grey rectangle on the right side.

Albeit somewhat vague, this argument applies whatever the initial size of the front region. It shows that the concept of location at a region, even in its finer-grained variants, cannot do justice to the geometrical structure of perspectival location.

Of course the problem dissolves if we understand perspectival location in terms of genuine relations which cannot be broken down into location relations to regions. It might well be in the nature of the front relation, e.g., that it holds between P and the white rectangle, but not between P and the black spot. This behaviour of the front relation might be a primitive fact, or it might be explainable in terms of its geometry.

2.2 Against the ambiguity thesis

For the time being, we haven't mentioned what we presented as the characterising feature of perspectival location in the introduction. There we said that perspectival locative terms are special in that the concepts they express involve dependence on a point of view. We will now try to give a precise meaning to this claim and to defend it against alternative analyses of perspectival location.

Explicitly relational statements of perspectival location appear in natural language in two ways. We say:

- (1) The old pine tree is to the left of the house.
- (2) The bike is to the left of the tree from your point of view.

On their surface structure, the two statements differ in that (1) predicates the left relation from two relata whereas (2) contains an explicitly ternary predicate. The question therefore arises whether (1) is an ellipsis for a ternary relation or whether, instead, the locative term 'left' is ambiguous between a binary and a ternary relation.

The idea that perspectival locative terms are ambiguous was introduced in the psycholinguistic discussion about spatial representation in language. Levelt [1984] and Levinson [1996a] are prominent defenders of the *ambiguity thesis*³, according to which projective terms are ambiguous between a binary and a ternary meaning. Their influential work has also had important impact on formal theories of perspectival location, which often reaffirm the ambiguity thesis [Eschenbach, 1999; Clementini, 2011].

A term is ambiguous if it admits more than one meaning. Examples of ambiguous terms are 'bank' (which is ambiguous between the sitting device one finds in parks and financial institutes), or 'duck' (which is ambiguous between a noun denoting an animal and a verb describing an act of taking cover) [Sennet, 2011]. To say that projective terms such as 'left' or 'front' are ambiguous thus comes down to saying that there are different relations, $left_1$ and $left_2$, say, that the term 'left' may refer to.

Defenders of the ambiguity claim understand the difference between $left_1$ and $left_2$ in terms of their arity. $left_1$ is a *binary* relation, whilst $left_2$ is a ternary relation; $left_1$ obtains between two spatial tenants (i.e., material objects, events, holes, etc.), whereas $left_2$ obtains among two spatial tenants and a *point of view*. If we say that the ball is in front of you, we think of the binary front relation, whilst we use the ternary front relation when we say that the bike is in front of the tree from your point of view.

I maintain that the ambiguity thesis is outright false and that it stems from a misinterpretation of the Levinsonian analysis of perspectival location. The ambiguity claim allows indeed for two interpretations. On one interpretation – which we shall call the genuine ambiguity interpretation – the ambiguity claim says that 'left', 'right', 'front', etc., are ambiguous in that they express either a binary or a ternary relation. Left as a binary relation indicates a left direction intrinsic to a spatial entity, whereas left as a ternary relation indicates a derived or extrinsic direction which is relative to a spatial entity, but derived from an additional entity that we may call a point of view. On the genuine ambiguity interpretation, 'The tree is in front of the house' says that the tree stands in the intrinsic front direction of the house, whereas 'The bike is in front of the tree (from your point of view)' says that the bike stands in the front direction relative to the tree, which is however derived from your point of view.

On this first, although not widespread, interpretation, the ambiguity claim has some plausibility. Some entities seem to possess front, left, right directions while others don't. However, even on this plausible interpretation the ambiguity claim leads to a double-structured semantics of projective terms and therefore to a multiplication of ambiguities: Every sentence containing a projective meaning becomes hereby ambiguous

between two competing meanings. Other things being equal, a homogeneous semantics for projective terms seems preferable. We will sketch below how such an alternative analysis could look like.

On its canonical interpretation, the ambiguity claim goes as follows. 'Left', 'right', etc., are ambiguous in that they may refer to a perspectival location dependent on an *intrinsic frame of reference* or a perspectival location dependent on a *relative frame of reference* [Levinson, 1996b; Eschenbach, 1999; Clementini, 2011]. A frame of reference is a geometrical entity, composed of axes centred on a spatial entity, from which the perspectival directions front, left, right, etc., can be derived. On the canonical interpretation, the difference between (1) 'The tree is in front of the house' and (2) 'The bike is in front of the tree' can be spelled out in terms of frames of reference: Whereas (1) depends on the intrinsic frame of reference of the house, (2) depends on a relative frame of reference centred on an additional entity.

Yet if (1) as much as (2) depends on a frame of reference, then the phenomenon we face is not ambiguity, but context sensitivity. A frame of reference being an element defined by context, projective terms are not ambiguous, but sensitive to a contextual variable. It does not make sense to speak of left and right as either binary or ternary relations. All projective terms refer to ternary relations insofar as they predicate ternary relations of two spatial entities and a *point of view*. If (1) and (2) depend on a frame of reference, then they predicate ternary relations between two spatial entities and a point of view. For they both involve three dependence relations: The fact that the tree is in front of the house depends first on the tree, second on the house and third on the house *qua frame of reference*. On its second interpretation, the ambiguity claim is thus outright false.

3 A Mereo-Topological Formalism for Perspectival Location

Having argued that projective terms predicate ternary relations from two spatial entities and a point of view and that the relevant relations are irreducible to absolute location relations to regions, we will now present the outlines of a qualitative formalism for perspectival location based on mereo-topology. We shall start with a short ontological analysis of the notion of a point of view, before then introducing the general idea of a new formalism.

3.1 An Ontological Analysis of Points of View

We have rejected the Levinsonian ambiguity claim arguing that projective terms predicate ternary relations. Nonetheless, the Levinsonian analysis of perspectival location in terms of frames of reference provides important insight into the nature of perspectival location. Levinsonian frames of reference, which have further been studied by e.g., Frank [1998], Eschenbach [1999] and Tenbrink and Kuhn [2011], show that perspectival location relations are essentially relative to a *reference direction*. Perspectival location is relative to frames of reference insofar as frames of reference provide (a) reference direction(s) with the help of which perspectival locations can

³My labelling.

be determined⁴.

Yet frames of reference are geometrical entities and it is therefore crucial to ask which entities *in the world* sustain the role of frames of reference [Eschenbach, 1999]. We dub these entities 'points of view' and argue that if points of view are to provide (a) reference direction(s), they must be understood as spatial regions standing in a visibility relation to some spatial entity.

First, it seems that points of view are spatial regions with special properties. Natural language suggests that we change our points of view when we move: We say that we can exchange points of view by changing places, and we refer to points of view in terms of locations (e.g., 'from here', 'from the Mont Blanc', 'from the Eiffel Tower'). This suggests that points of view must be places or spatial regions, which somehow possess the ability to provide reference directions.

Second, this ability to provide reference directions calls for an analysis of points of view in terms of *relations*. We submit that directions are features of non-symmetric relations. It seems indeed difficult to assume that directions be monadic or intrinsic properties, i.e., properties characterising one sole entity. To have a direction or to be directed is always to be directed *towards* something. Massin [2010] explains in great detail why we must regard directions as relations. Directions generally stand for two features: an orientation and a sense [Massin, 2010]. The orientation of an entity indicates how it stands to other entities and seems therefore to be a spatial relation. We typically indicate orientation by saying, e.g., that the cities Lausanne and Lucerne are SW–NE oriented [Newman, 2002]. If this relation is non-symmetric, its relata are ordered and it is intelligible to speak of the orientation as having a sense. It is not clear what it would mean to say of a monadic property that it has a sense. Sense, just as orientation, is typically a feature of (non-symmetric) relations. As a result, we conclude that an entity x has a direction towards y or is directed towards y if, and only if, x stands in a non-symmetric spatial relation to y ⁵.

Applied to our case, this analysis entails that a spatial region is a point of view only if it stands in a non-symmetric spatial relation to some other entity. A way of spelling out this insight more precisely is as follows. A spatial region x is a point of view if, and only if, x stands in a relation of visibility to some entity y . y is a reference object for x . x 's monadic property of being a point of view is derived from the visibility relation to y in which it stands.

We do not understand visibility as a psychological relation requiring an actual viewer, but as a (non-symmetric) spatial relation constrained by optical facts. To be visible from P is to be within a certain range of distance from P whose shape and size are determined by physiological features of a visual apparatus and its interaction with its environment. As

⁴One reference direction is sufficient for the two-dimensional case.

⁵We are of course cutting short the discussion about the nature of vectorial properties, vectorial properties being properties that *have a direction* [Leuenberger and Keller, 2009]. The standard view about most vectorial properties is relational, but it has been challenged by some authors. See e.g., Bigelow and Pargetter [1989] for an account of velocity as a monadic property.

it is conceivable that a is visible from b without b being visible from a because of e.g., lighting conditions, visibility is a non-symmetric relation. Whether or not a visibility relation holds depends on physiological features, but we take it that this does not entail dependence on actual psychological acts.

It follows that points of view can provide reference directions as they stand, at each moment of time, in a non-symmetric spatial relation to various objects in their surrounding. The relevant relation is visibility. If A is to the left of B from point of view P , it is because B is visible from P , and this visibility relation yields a direction from P to B with the help of which 'left', and 'right', etc., can be meaningfully determined⁶.

The same goes for statements with apparent binary structure. The statement 'The tree is in front of the house' is elliptic for 'The tree is in front of the house *with respect to the house's point of view*'. The latter is a spatial region, part of the spatial region occupied by the house, directed towards some appropriate reference entity B . The statement 'The tree is in front of the house' is true with respect to the fact that the house's point of view is directed towards some suitable entity B . We will refine this analysis below.

3.2 Towards a new formalism

To integrate perspectival location into a philosophical theory of spatial representation based on mereo-topology and detached location at least one addition is thus required. Points of view need to enter into a theory of spatial representation. As points of view are defined in terms of visibility relations, it is natural to add a binary predicate ' $Vis(x, y)$ ' for ' y is visible from x '. We may then use the visibility relation to define a unary predicate ' $PoV(x)$ ' for ' x is a point of view'. These predicates must be properly axiomatised. For instance, we might want to use mereo-topological predicates to characterise points of view as self-connected regular spatial regions⁷. To geometrically contain the spatial relationship between a point of view, its reference object and a further object standing in a perspectival relation to the reference object, we may further introduce a primitive binary predicate ' $FoV(x, y)$ ' for ' x is a field of view of y '. If a and b stand in a perspectival relation with respect to point of view P , they must be contained in a field of view associated with P . A field of view can be characterised as self-connected regular spatial region appropriately linked to P .

To actually compute perspectival location relations from a point of view and one of its reference objects basic mereo-topological notions are not expressive enough. A suitable instrument is however the convex hull operator CH [Cohn, 1995]. Via the convex hull of the mereological sum of a point of view P and its relevant reference object B we get a qualitative geometrical instrument for expressing orientation that we may use to derive perspectival location relations with the

⁶Not all calculi present in the literature share this assumption, for some take the reference direction to be given by a *viewing direction* which might not necessarily coincide with the direction towards the second relatum. However, we have good reasons to think that the two models can be conflated [Moratz and Tenbrink, 2009].

⁷For a precise definitions of the mereo-topological predicates, see [Varzi, 2007].

help of the remaining apparatus of our theory (that comprises mereo-topological and detached locative concepts).

By way of example we consider the ternary front and behind relations between a point of view P , a reference object B and an object A . We suppose a suitable qualitative axiomatisation of the convex hull operator CH as given. To get to the definitions of front and behind, we first need to define a family of predicates involving the convex hull operator and the mereological parthood relation $\mathcal{P}(\cdot, \cdot)$.

- (D1) $K(A, B, P) =_{def} CH(A + B + P) = CH(A + P) + CH(B + P)$
- (D2) $K_1(A, B, P) =_{def} K(A, B, P) \wedge \mathcal{P}(CH(A + P), CH(B + P))$
- (D3) $K_2(A, B, P) =_{def} K(A, B, P) \wedge \mathcal{P}(CH(B + P), CH(A + P))$
- (D4) $G(A, B, P) =_{def} CH(A + B + P) = CH(A + P) + CH(A + B)$
- (D5) $G_1(A, B, P) =_{def} G(A, B, P) \wedge \neg\mathcal{P}(CH(A + P), CH(A + B)) \wedge \neg\mathcal{P}(CH(A + B), CH(A + P))$
- (D6) $H(A, B, P) =_{def} CH(A + B + P) = CH(B + P) + CH(B + A)$
- (D7) $H_1(A, B, P) =_{def} H(A, B, P) \wedge \neg\mathcal{P}(CH(B + P), CH(B + A)) \wedge \neg\mathcal{P}(CH(B + A), CH(B + P))$

All the predicates that we define express a mereotopological relation between convex hulls of the mereological sums of respectively A and B , A and P and B and P . For all definitions, we suppose that $CH(A)$, $CH(P)$ and $CH(B)$ are not pairwise topologically connected. We can now therefore define:

- (D8) $Front(A, B, P) =_{def} K_1(A, B, P) \vee G_1(A, B, P)$
- (D9) $Behind(A, B, P) =_{def} K_2(A, B, P) \vee H_1(A, B, P)$

Figure 2 illustrates the intended model for $Front(A, B, P)$ and $Behind(A, B, P)$. We use axiomatic principles to determine that the third relatum of the front and the behind relation must be a point of view and the second relatum one of its reference objects. In figure 2 we see the point of view as a small region of space. The visibility relation between P and B is not depicted, but is expressed by suitable axiomatic principles involving points of view and fields of view. To compute the front and behind relation, we use the convex hull of $P + B$ and its mereo-topological relations to A , $CH(A + P)$ and $CH(A + B)$. Left and right, and even more finegrained notions of front-left and behind-left can be defined in a similar vein.

The resulting formalism bears some similarity to the early work of Zimmermann and Freksa [1996] and the much more recent approach of Clementini and Billen [2006], yet it is formulated as an extension of mereo-topology and location theory in first-order logic. Frames of reference only appear in forms of points of view which stand in relation to some reference objects.

Our formalism respects the consequences of the two observations we stated in section 2. Perspectival relations are

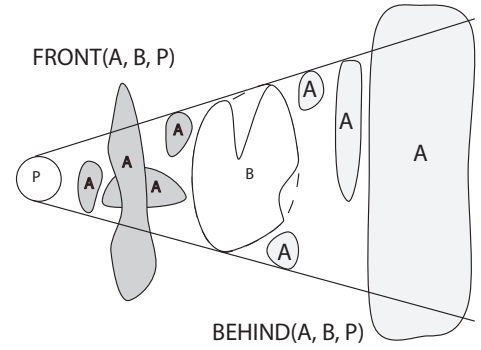

Figure 2: Possible configurations for the two cases A is in front of B from P and A is behind B from P .

ternary relations obtaining between two spatial tenants and a point of view. Moreover, perspectival location is understood in terms of mereo-topological relations and convexity, and is not reduced to the concept of location at a region.

One further advantage of our analysis over usual analyses of frames of reference is its focus on ontological matters. Points of view are separated from actual viewers and are therefore identified by their mind-independent qualitative geometrical role. Moreover, we avoid intrinsic directions and instead construe directions as relations between regions and entities in space.

3.3 The "intrinsic" case

So far we have rejected the ambiguity claim and argued that all projective terms express ternary spatial relations between two spatial tenants and a point of view. However, we haven't showed in much detail how this analysis should apply to apparently "binary" structures, expressed by e.g., 'The tree is in front of the house'. In this section we propose a rough sketch of how our analysis can be extended to such cases. Our contention is that apparently binary cases must be regarded as limit of the ternary case.

When analysing the statement 'The tree is in front of the house', we suggested that the front relation is here predicated with respect to the house's point of view, which stands in a visibility relation to some suitable reference object. 'The tree is in front of the house' differs thus from 'The bike is in front of the tree (from some point of view)' in that the visibility relation cannot be construed as a relation between point of view and second relatum (i.e., house). These complications arise because point of view and second relatum "coincide": the point of view of the house is a spatial region comprised within the spatial location of the house.

An interesting way to unify the two stories and to get rid of the additional reference object for the binary case is to consider the binary case as a limit scenario of the ternary case. Suppose that B be what we described as a reference object of the house's point of view. B is visible from the house's point of view and we can exploit the visibility relation to construe the reference direction relevant for analysing the truth-value of a perspectival proposition. We can understand the binary

case as the limit of the constellation in which B approaches – and ultimately coincides – with the house⁸. This is promising, for it allows us to analyse any perspectival relation in terms of a spatial entity (the first relatum), a reference object (the second relatum) and a point of view (the third relatum), without relying on intrinsic directions.

Formally, this analysis can be built as follows: We take a sequence $\{B_i\}_{i=1}^{\infty}$ of reference objects in the field of view associated with the viewpoint of the house qua point of view. The sequence approaches the house in terms of distance, shape and size, with $\lim_{i \rightarrow \infty} \{B_i\} = \textit{House}$. (1) can then be analysed as being about the ternary relation that obtains between the tree, a reference object B and the house’s point of view, where $B = B_n$ for $n > N$. That is, if $P_{\textit{House}}$ stands for the house’s point of view:

$$(D.2) \quad \textit{Left}(\textit{Tree}, \textit{House}, P_{\textit{House}}) = \textit{Left}(\textit{Tree}, \lim_{i \rightarrow \infty} B_i, P_{\textit{House}})$$

An interesting feature of this analysis appears when we generalise the reasoning to other perspectival relations. Whereas the right relation behaves like the left relation, things are different when it comes to the front relation. What Levinson calls an “intrinsic” front relation must be analysed in terms of a ternary *behind* relation. An object A is in front of the house (with respect to the house itself) if, and only if, it is *behind* a reference object approaching, and ultimately coinciding, with the house:

$$(D.3) \quad \textit{Front}(A, \textit{House}, P_{\textit{House}}) = \textit{Behind}(A, \lim_{i \rightarrow \infty} B_i, P_{\textit{House}})$$

Although this analysis may seem unnatural at first sight, it can claim some credit. If we think of the house as the reference object which together with the point of view determines the reference direction, it is clear that what turns to be in front of the house must actually lie behind the house as reference object. Figure 3 illustrates this reasoning.

Of course the formal details of this approach remain to be worked out. Also, this approach doesn’t change the fact that the choice of reference objects in relation to a point of view is mind-dependent and can therefore not be mastered by the kind of formal theory of spatial representation that we aim at. The choice of $\{B_i\}_i^{\infty}$ is arbitrary, yet as soon as it is fixed, we can formally deal with everything else. The benefits of our approach are clear: It presents an analysis of the Levinsonian “intrinsic” in terms of the “relative” case and thereby allows to give a precise unified account of perspectival location. It avoids intrinsic directions by understanding

⁸We can think in terms of an analogy to instantaneous velocities. As Massin writes, on the relational view (which denies the existence of intrinsic directions) velocities are matters of spatio-temporal relations between different positions of a body at different times [Massin, 2010]. “Instantaneous velocities refer to the limit of the average velocity when the variation of time tends towards 0. [This means that instantaneous velocity is also defined in terms of later positions,] although very near ones” [Massin, 2010]. Our case is analogous: In the intrinsic case, the reference direction is construed as a relation between the point of view and a reference object that tends towards the house and, in the limit, coincides with the house. We can still understand direction in terms of a spatial relation, although between very close spatial entities.

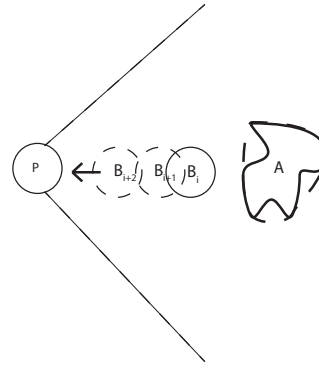

Figure 3: The Levinsonian “intrinsic” front relation as limit case of a ternary behind relation.

the reference direction necessary for the “intrinsic” case in terms of a relation between a point of view and a reference object approaching the second relatum of the actual perspectival relation. It also supports the intuition that the “relative” case is metaphysically prior to the “intrinsic” case. Although the converse intuition has also been upheld in the literature [Levinson, 1996a], things seem clear from a metaphysical (and from a formal) standpoint: Whilst the “intrinsic” case can be explained in terms of the “relative” case, the converse is not true. If the contrary has been defended in the literature, it is surely because psychological considerations have played a more important role than ontological ones.

4 Conclusion

Our discussion suffices to determine the main ingredients of a mereo-topological theory of spatial representation that accounts for both detached and perspectival location. Such a theory requires the addition of new and genuine ternary predicates standing for perspectival relations, the definition of a predicate for points of view and instruments for explaining the special relationship between a point of view and its reference objects. We have given some hints at how this theory could look like, yet its full elaboration remains object of future work. In contrast to the well known qualitative orientation calculi and unlike psycholinguistic analyses, a philosophically motivated theory of spatial representation tries to get the ontology right. What is it in the world that makes it possible to perspectivally locate things with respect to one another? A response to this question requires an ontological analysis before the examination of computational details. We hope that this article goes some way towards an answer to this question, thus providing a more robust basis for the development of further qualitative theories of spatial representation.

Acknowledgments

I am indebted to Achille Varzi, Olivier Massin and Basilio Noris for helpful discussion.

References

- [Bigelow and Pargetter, 1989] John Bigelow and Robert Pargetter. Vectors and Change. *The British Journal for the Philosophy of Science*, 40(3):289–306, 1989.
- [Casati and Varzi, 1997] Roberto Casati and Achille Varzi. Spatial Entities. In *Spatial and Temporal Reasoning*, pages 73–96. Kluwer, Dordrecht, 1997.
- [Casati and Varzi, 1999] Roberto Casati and Achille Varzi. *Parts and Places*. The MIT Press, Cambridge, Mass., 1999.
- [Clementini and Billen, 2006] Eliseo Clementini and Roland Billen. Modeling and Computing Ternary Projective Relations between Regions. In *Knowledge and Data Engineering*, volume 18 of *IEEE Transactions*, pages 799–814, 2006.
- [Clementini, 2011] Eliseo Clementini. Directional Relations and Frames of Reference. *Geoinformatica*, 18(6):1–21, 2011.
- [Cohn, 1995] Anthony G. Cohn. A Hierarchical Representation of Qualitative Shape based on Connection and Convexity. In *Spatial Information Theory: A Theoretical Basis for GIS*, pages 311–326. 1995.
- [Eschenbach, 1999] Carola Eschenbach. Geometric Structures of Frames of Reference and Natural Language Semantics. *Spatial Cognition and Computation*, 1:329–348, 1999.
- [Frank, 1991] Andrew Frank. Qualitative Spatial Reasoning about Cardinal Directions. In *Proceedings of ACAI 1991*, pages 157–167, 1991.
- [Frank, 1998] Andrew Frank. Formal Models for Cognition – Taxonomy of Spatial Location Description and Frames of Reference. In *Spatial Cognition*, pages 293–312. Springer Verlag, Berlin, Heidelberg, 1998.
- [Leuenberger and Keller, 2009] Stephan Leuenberger and Philipp Keller. Introduction. the Philosophy of Vectors. *Dialectica*, 63(4):369–380, 2009.
- [Levelt, 1984] W. J. M. Levelt. Some Perceptual Limitations on Talking about Space. In A. J. van Doorn, W. A. van der Grind, and J. J. Koenderink, editors, *Limits in Perception*, pages 323–358. VNU Science Press, Utrecht, 1984.
- [Levinson, 1996a] Stephan C. Levinson. Frames of Reference and Molyneux’s Question: Crosslinguistic Evidence. In *Language and Space*, pages 109–169. MIT Press, Cambridge, Mass., 1996.
- [Levinson, 1996b] Stephan C. Levinson. Language and Space. *Annual Review of Anthropology*, 25:353–382, 1996.
- [Massin, 2010] Olivier Massin. The Metaphysics of Forces. *Dialectica*, 63(4):555–589, 2010.
- [Moratz and Tenbrink, 2009] Reinhard Moratz and Thora Tenbrink. Spatial Reference in Linguistic Human-Robot Interaction: Iterative, Empirically Supported Development of a Model of Projective Relations. *Spatial Cognition and Computation: An Interdisciplinary Journal*, 6(1):63–107, 2009.
- [Newman, 2002] Andrew Newman. Converse Relations, Vectors, and three Theses from Armstrong. *Metaphysica*, 3:65–81, 2002.
- [Parsons, 2006] Josh Parsons. Theories of Location. In Dean Zimmermann, editor, *Oxford Studies in Metaphysics*, pages 193–210. Oxford University Press, New York, 2006.
- [Renz and Mitra, 2004] Jochen Renz and Debasis Mitra. Qualitative Direction Calculi with Arbitrary Granularity. In *PRICAI 2004: Trends in Artificial Intelligence, 8th Pacific Rim International Conference on Artificial Intelligence*, pages 65–74. 2004.
- [Sennet, 2011] Adam Sennet. Ambiguity. In Edward N. Zalta, editor, *The Stanford Encyclopedia of Philosophy (Summer 2011 Edition)*. 2011.
- [Tenbrink and Kuhn, 2011] Thora Tenbrink and Werner Kuhn. A Model of Spatial Reference Frames in Language. In M. Egenhofer et al., editor, *COSIT 2011*, volume 6899 of *Lecture Notes in Computer Science*, pages 371–390. Springer Verlag, Heidelberg, 2011.
- [Varzi, 2007] Achille Varzi. Spatial Reasoning and Ontologies: Parts, Wholes, and Locations. In *Handbook on Spatial Logic*, pages 945–1038. Springer Verlag, Berlin, 2007.
- [Zimmermann and Freksa, 1996] Kai Zimmermann and Christian Freksa. Qualitative Spatial Reasoning Using Orientation, Distance, and Path Knowledge. *Applied Intelligence*, 6:49–58, 1996.

Towards a Mereotopology with Pointfree Semantics

S. Borgo

Laboratory for Applied Ontology, ISTC-CNR, Trento

KRDB FUB, Bolzano

Italy

stefano.borgo@cnr.it

Abstract

We motivate and formalize a mereotopological theory of space based on two orthogonal primitives, namely, *parthood* and *simple region*. Parthood is axiomatized as in extensional closure mereology while the axiomatization of simple region, a unary predicate, is new and provides the topological layer of the theory. The resulting theory, while having a standard semantics, is independent of the notion of point both at the syntactic and at the semantic level. We believe that this approach is more suitable than usual forms of mereotopology for studying the modeling of space in human-like agents.

1 Introduction

The study of space can be motivated from a variety of perspectives, e.g. in human orientation and travel planning (agent-centered viewpoint), in system design and logistics (object-centered viewpoint) and in foundational and logical systems (formal and/or philosophical viewpoints). From the 90s there have been considerable efforts in formulating theories of space suitable for artificial intelligence and knowledge representation. Most of the proposals were driven by foundational or cognitive arguments which led to abandon classical mathematical views, like set-theory, for less prominent theories, e.g. mereology. This paper falls within this research line and is motivated by the formal study of space conceived as a cognitive entity. More precisely, we aim to provide a mereotopology of space which we hope is better suited to model spatial information as perceived and understood by cognitive agents.

A mereotopology is a formal theory based on mereology, the theory of parthood, and topology, the theory of connection. There are several well known mereotopologies in the literature (we follow the terminology in [Casati and Varzi, 1999]) like the General Extensional Mereotopology (GEMT) [Grzegorzczuk, 1960], Eschenbach and Heydrich [Eschenbach and Heydrich, 1995], atomistic theories [Masolo and Vieu, 1999], Whitehead [Whitehead, 1929] (reformulated by Clarke in [Clarke, 1981]), the Region Connection Calculus (RCC) [Randell *et al.*, 1992] and the Closed Region Calculus (CRC) [Eschenbach, 1999], to name a few.

In many cases, these systems have been further extended with non-mereotopological features to model geometrical information, e.g. see [Gerla, 1995; Cohn and Renz, 2007; Borgo and Masolo, 2010].

The system we introduce relies on assumptions which are shared by well known theories like RCC, namely: the domain of quantification contains only regular open (alternatively closed) regions,¹ in particular points and boundary-like entities are not in the domain; the universe is an element of the domain; the empty region is not in the domain; the domain is closed under the mereological operators of sum, product (if the factors overlap) and complement (except for the universe); there are no atomic regions; the parthood and connection relations are extensional.

In short, we propose a mereotopology based on two independent primitives: *P*, reading “*being part of*” (binary) and *SR*, “*being a simple region*” (unary). The parthood relation is well known in the literature and is axiomatized as in extensional closure mereology (CEM) [Casati and Varzi, 1999]. The originality of our work is the study of the simple region predicate which, by distinguishing regions perceived as single pieces of space from those composed by distinct pieces, provides a formalization of space arguably closer to human perception.

Beside the cognitive bend, which motivates the search for formal theories of space distinct from standard geometries, and the conceptual distinction between mereology and topology, which are interlaced in approaches like RCC, our system adds a further contribution by formulating a theory of space satisfying the standard spatial properties while requiring no notion of point. Differently from RCC-like systems, both the syntax and the semantics of our theory are given with neither explicit nor implicit reference to points.

The *SR* predicate has been introduced as a primitive in [Borgo *et al.*, 1996] but is known as a derivate notion in

¹Technically a regular open region is an open set which is equal to the topological interior of its closure. In particular, a regular open region *A* is locally a (topological) manifold of dimension *n*, for *n* the dimension of the space, since it is a separable topological space for which each point is contained in an open subset (in *A*) which is homeomorphic to an open subset of \mathbb{R}^n . In turn, regular closed regions are closed sets equal to the topological closure of their interior.

the literature with different names, e.g., *ICON* (interior connected) [Gotts, 1994], *SSC* (strong connected) [Casati and Varzi, 1999]; *SCON* (strongly self connected) [Dugat *et al.*, 1999]; *FSC* (firmly self-connected) [Varzi, 2007]; and *C_b* (strong connected) [Thompson and Oosterom, 2009]. For some time there has been doubts about the expressive strength of the *SR* predicate which explains why it has not been exploited as a primitive for mereotopology up to today.

As an historical note, the system we study in this paper can be seen as a development of the mereotopology underlying the mereogeometry presented in [Borgo *et al.*, 1996] as well as a conceptual and formal change of the topological layer of RCC since, after all, these systems originate from a common viewpoint on space formalization.

Structure of the paper. Section 2 introduces the notion of simple region and the next section reports recent results on the expressive power of this predicate. Section 4 reviews CEM, the mereological layer of our theory, plus the universe predicate but no atoms. Section 5 presents a new axiomatization of *SR*, proves basic theorems and shows that the theory is consistent. Section 6 describes future work.

2 Simple Regions

The cognitive interest for the simple region predicate rises from the study of visual perception and because everyday objects relevant at the human (mesoscopic) level tend to occupy regions that are “everywhere thick”. Informally, this means that one can move to any place within the object without going through the boundary of the object itself: compare regions in column 1 with those in columns 2 and 3 of Fig. 1.

Within topology, the issue can be restated by distinguishing forms of connection, namely, *self-connection* vs *strong self-connection*: in any attempt to divide a self-connected region in two subregions, the latter must have at least one boundary point in common. Each of the six regions in column 1 and 2 of Figure 1 is an example of a self-connected region. A strong self-connected region is a self-connected region such that, when divided in two subregions, these must share at least an extended part of their boundaries (more precisely, a boundary of dimension $n - 1$ for n the dimension of the space). In Figure 1, only the three regions of column 1 are strong self-connected, those in column 2 and 3 are not. For instance, the figure in column 2 bottom is formed by the sum of a square and a triangle. Both the square and the triangle are strong self-connected but their sum is only self-connected. Similarly for the other regions in column 2.

The self-connected or point-connected predicate, formally written *PntC*, is definable in \mathbb{R}^n from the RCC point-connection relation *C* by formalizing the property described earlier [Randell *et al.*, 1992]:

$$PntC(x) \stackrel{\text{def}}{=} \forall yz [x = y + z \rightarrow C(y, z)]$$

[RCC point-connected region]

For $+$ interpreted as set-theoretical union and $C(y, z)$ holding provided the interpretations of y and z share at least a boundary point, this formula says that a region x is *PntC* when, if arbitrarily divided in two, the resulting regions share a boundary point.

The predicate of strong self-connection, hereafter simple region, is also definable from the RCC relation *C*

$$SR_C(x) \stackrel{\text{def}}{=} \forall y \exists z [NTPP(y, x) \rightarrow (P(y, z) \wedge NTPP(z, x) \wedge PntC(z))]$$

[RCC simple region]

First note that *C* suffices to define parthood (*P*), interpreted as set-inclusion, and also the relation of non-tangential proper part (*NTPP*) which holds for y and x when $P(y, x)$ and y is not point-connected to the (set-theoretical) complement of x . Thus, the above formula says that x is a simple region (a strong self-connected region) whenever for any part y of x , which shares no boundary point with the complement of x , there is a part of x , also not sharing boundary points with the complement of x , which contains y and is self-connected. The reader can see how this definition rules out the region at the bottom of column 2 in Figure 1 by choosing y to be the sum of two disjoint regions, one being a circle at the center of the square (not touching the square boundary) and the other a circle at the center of the triangle (also not touching the triangle boundary). In this case, no region z satisfying the formula exists. The other cases in Figure 1 column 2 and 3 are dealt with in a similar way.

Since *SR* itself is definable from *C*, one can enhance mereology with the unary predicate *SR* without leaving the realm of mereotopology. The other direction, that is, the question whether *C* can be defined from *SR* and *P* has been addressed only recently.

3 From *SR* to point-connection

In [Pratt-Hartmann, 2007, Sect. 2.3] Pratt-Hartmann proposed structures $ROQ(\mathbb{R}^n)$, $ROP(\mathbb{R}^n)$ and $ROS(\mathbb{R}^n)$ as truly region-based models of space. The main argument is that in other structures like $RO(\mathbb{R}^n)$, the unrestricted mereotopology of regular open sets in \mathbb{R}^n , there are various pathological sets whose existence is not cognitively justified nor needed in qualitative knowledge representation [Pratt-Hartmann and Schoop, 2002].

The following definitions are from [Pratt-Hartmann, 2007, Sect. 2.3]. For basic topological notions see, e.g., [Munkres, 2000].

DEFINITION 1. A subset of \mathbb{R}^n , say u , is regular open (in \mathbb{R}^n) if u is equal to the interior of its closure. We denote the set of regular open subsets of \mathbb{R}^n by $RO(\mathbb{R}^n)$.

DEFINITION 2. A set $u \subseteq \mathbb{R}^n$ is semi-algebraic if, for some integers n, m , there exist a formula $\phi(x_1, \dots, x_n, y_1, \dots, y_m)$ in the first order language with signature $\langle \leq, +, \cdot, 0, 1 \rangle$ (over \mathbb{R}^n) and real numbers b_1, \dots, b_m such that: $u = \{(a_1, \dots, a_n) \in \mathbb{R}^n \mid \mathbb{R}^n \models \phi(a_1, \dots, a_n, b_1, \dots, b_m)\}$. We denote the set of regular open, semi-algebraic sets in \mathbb{R}^n by $ROS(\mathbb{R}^n)$.

DEFINITION 3. A basic polytope in \mathbb{R}^n is the product, in $RO(\mathbb{R}^n)$, of finitely many half-spaces. A polytope in \mathbb{R}^n is the sum, in $RO(\mathbb{R}^n)$, of any finite set of basic polytopes. We denote the set of polytopes in \mathbb{R}^n by $ROP(\mathbb{R}^n)$.

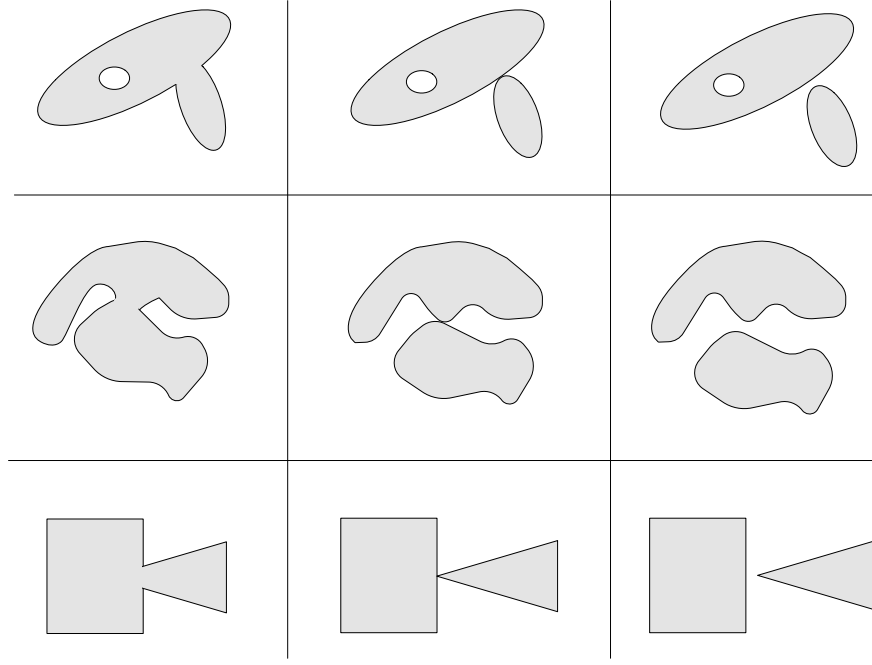

Figure 1: Examples of simple regions (column 1) vs non-simple regions (columns 2, 3) in dimension 2.

DEFINITION 4. A basic rational polytope in \mathbb{R}^n is the product, in $RO(\mathbb{R}^n)$, of finitely many rational half-spaces. A rational polytope in \mathbb{R}^n is the sum, in $RO(\mathbb{R}^n)$, of any finite set of basic rational polytopes. We denote the set of rational polytopes in \mathbb{R}^n by $ROQ(\mathbb{R}^n)$.

Clearly, $ROQ(\mathbb{R}^n) \subsetneq ROP(\mathbb{R}^n) \subsetneq ROS(\mathbb{R}^n) \subsetneq RO(\mathbb{R}^n)$.

The suitability of SR as the only topological primitive in mereotopology follows from [Borgo, 2013] where a definition of point-connection in terms of P and SR is given. The definition is proven to be correct in the structures just introduced for dimension 2. More precisely, in all the structures $ROQ(\mathbb{R}^2)$, $ROP(\mathbb{R}^2)$, $ROS(\mathbb{R}^2)$ and $RO(\mathbb{R}^2)$ relation C is explicitly definable in the first order language with P and SR provided $P(x, y)$ is interpreted by $x^I \subseteq y^I$ and $SR(x)$ by ‘ x^I is a simple region’ (where x^I is the interpretation of variable x in the structure.)

Although partial, these results show that SR has all the potentialities to be taken as a topological primitive at least for spatial theories based on mereology. Furthermore, its intuitive character makes it a good candidate for cognitively motivated theories of space.

From now on, we will use the term ‘region’ to mean an element of the domain in the structures introduced in this section. Although the results (in this section and in the whole paper) hold also for the analogous structures build out of regular closed regions [Pratt-Hartmann, 2007, Sect. 2.3], for the sake of simplicity we will always assume that regions are open in \mathbb{R}^n .

4 Closed Extensional Mereology

Formally, a mereology is a first-order logical theory with a binary relation, generally written P , as the only primitive element. The characterization of P forces the interpretation of this relation to satisfy constraints normally associated to the (informal) notion of parthood. From P , adopting the intended interpretation, a series of related relations can be defined as follows

- (D1) $O(x, y) \stackrel{\text{def}}{=} \exists z [P(z, x) \wedge P(z, y)]$ [x and y overlap]
- (D2) $PO(x, y) \stackrel{\text{def}}{=} O(x, y) \wedge \neg P(x, y) \wedge \neg P(y, x)$
[x and y properly overlap]
- (D3) $SUM(x, y, z) \stackrel{\text{def}}{=} P(x, z) \wedge P(y, z) \wedge \neg \exists w [P(w, z) \wedge \neg O(w, x) \wedge \neg O(w, y)]$
[z is the sum of x, y]
- (D4) $PROD(x, y, z) \stackrel{\text{def}}{=} \forall v [(P(v, x) \wedge P(v, y)) \leftrightarrow P(v, z)]$
[z is the product of x, y]
- (D5) $COMPL(x, y) \stackrel{\text{def}}{=} \forall w [P(w, y) \leftrightarrow \neg O(w, x)]$
[y is the complement of x]
- (D6) $U(x) \stackrel{\text{def}}{=} \forall y [P(y, x)]$ [universe]

There are several mereological theories aimed to model different intuitions about parthood. We take an approach that received large consensus in areas like philosophy and knowledge representation [Simons, 1987; Casati and Varzi, 1999; Randell *et al.*, 1992]. The axiomatization of P is taken from [Casati and Varzi, 1999] and is known as atomlessness *closed extensional mereology* (CEM) with *universe* (since it ensures that the universe exists and is unique).

- (A1) $\forall x [P(x, x)]$ [reflexivity]
(A2) $\forall xy [(P(x, y) \wedge P(y, x)) \rightarrow x = y]$ [antisymmetry]
(A3) $\forall xyz [(P(x, y) \wedge P(y, z)) \rightarrow P(x, z)]$ [transitivity]
(A4) $\forall xy \exists z [\neg P(y, x) \rightarrow (P(z, y) \wedge \neg O(z, x))]$
[strong supplementation]
(A5) $\forall xy \exists z \forall w [O(w, z) \leftrightarrow (O(w, x) \vee O(w, y))]$
[sum existence]
(A6) $\forall xy \exists z \forall v [O(x, y) \rightarrow (P(v, z) \leftrightarrow (P(v, x) \wedge P(v, y)))]$
[product existence]
(A7) $\forall x \exists y [PP(y, x)]$ [atomlessness]
(A8) $\exists z \forall x [P(x, z)]$ [universe existence]

From the axiomatization, the operators $+$ (sum), \cdot (product) and $*$ (complement) can be introduced in the language following the relations (D3-D5):

- (D7) $SUM(x, y, z) \equiv z = x + y$
(D8) $PROD(x, y, z) \equiv z = x \cdot y$
(D9) $COMPL(x, y) \equiv y = x^*$

Also, from the axiomatization we can prove that the universe is unique. We can thus introduce a new constant U in the language for the universe.

The semantics of mereology is given by the standard first-order semantics with the following clause for the primitive relation P : $\langle D, I \rangle \models P(x, y)$ iff $x^I \subseteq y^I$.

5 The Topological Layer

Formally, one cannot say much about the unary predicate SR in isolation. We thus characterize the interpretation of SR by constraining how this predicate interacts with parthood and its derived mereological operators. Note that we could use SR to define a relation of strong connection and then axiomatize the latter along the lines of the RCC axiomatization. However, from a foundational viewpoint it is incoherent to axiomatize a primitive via a derived notion. Furthermore, we are interested in identifying the crucial properties of SR itself. In this sense, the three axioms below should be considered as a first proposal to formalize the SR primitive. In the informal descriptions, we write ‘a region is strongly connected to another’ to mean that their sum is a simple region.

- (A9) The first axiom for SR tells us that any region must contain a simple region which is maximal in it. When a region is not itself a simple region, maximality is needed to allow us to isolate the SR ‘components’ of a region.
 $\forall x \exists y [P(y, x) \wedge SR(y) \wedge \forall z [(P(z, x) \wedge SR(z) \wedge O(z, y)) \rightarrow P(z, y)]]$
[locally maximal SR]
(A10) The second axiom for SR says that the sum of overlapping simple regions is always a simple region. The axiom follows from the fact that any cut of such a region must cut at least one of the two simple regions.
 $\forall xy [(SR(x) \wedge SR(y) \wedge O(x, y)) \rightarrow SR(x + y)]$
[SR coherence]

- (A11) The third axiom for SR says that for any pair of regions that combined form a simple region x , there is a simple region part of x which overlaps both and can be strongly connected only to regions overlapping x :
 $\forall xyz [(SR(x) \wedge x = y + z) \rightarrow \exists u [SR(u) \wedge PO(u, y) \wedge P(u, x) \wedge \forall v [O(v, x) \vee \neg SR(u + v)]]]$
[SR thickness]

Axioms (A9), (A10) and (A11) formalize simple and orthogonal properties of SR . In particular, (A10) and (A11) constrain the case of simple regions obtained as sum of other regions. Note also that the axioms do not constrain the universe relatively to SR : both $SR(U)$ and $\neg SR(U)$ are compatible with the given axiomatization.

Here are some consequences of the axioms:

PROPOSITION.

1) Regions have non-tangential (in the sense of SR) proper parts that are also simple regions, formally:

$$\forall x \exists y [P(y, x) \wedge SR(y) \wedge \forall z [O(z, x) \vee \neg SR(y + z)]]$$

2) If the universe is a simple region, the non-tangential simple regions of point 1) are not maximal.

3) Every region has parts which are simple regions, formally: $\forall x \exists y [P(y, x) \wedge SR(y)]$ (SR downward existence), and also parts which are not, formally: $\forall x \exists y [P(y, x) \wedge \neg SR(y)]$.

Proposition 1) follows from (A7) and (A11). Proposition 2) follows from (A9). Proposition 3), the first claim follows from Proposition 1); for the second, let z be a simple region part of x (from SR downward existence). From Proposition 1), let w be a simple region part of $x - z$. Since $\neg O(z, w)$, from Proposition 1) again we have $\neg SR(w + z)$ and now it suffices to take $y = w + z$.

It remains to prove that the axiomatic system (A1)–(A11) is consistent. We show that the structures of Section 3 are models of the theory for the given interpretations of P and SR . It is well known that CEM, with or without atoms and with or without the universe, holds in $RO(\mathbb{R}^n)$ as well as in its substructures $ROQ(\mathbb{R}^n)$, $ROP(\mathbb{R}^n)$, $ROS(\mathbb{R}^n)$. We thus focus on axioms (A9)–(A11). Since the proofs in all these structures are similar, we give them explicitly for $RO(\mathbb{R}^n)$ only. The proofs we give do not depend on the dimension of the space but that of (A11). In this latter case, to keep the presentation simple, we give it only for $n = 2$.

LEMMA. In $RO(\mathbb{R}^n)$ the propositions (A9), (A10) and (A11) are valid.

Proof. (A9): Let p be an interior point of the open set x^I . Then, there exists an open ball b_p (thus a simple region) with center p and contained in x^I . Let y^I be the maximal connected open set of x^I which contains p . Note that y^I exists since the structure respects components [Pratt-Hartmann, 2007, Sect. 2.3] and is itself a simple region since x^I is open.

(A10): (By contradiction) If not, then $(x + y)^I$ can be divided in two regions, say a and b , which are either disjoint or share only isolated points. Since x^I and y^I are simple regions, we must have $a = x^I$ or $a = y^I$. Thus, x^I and y^I have no common part (contradiction).

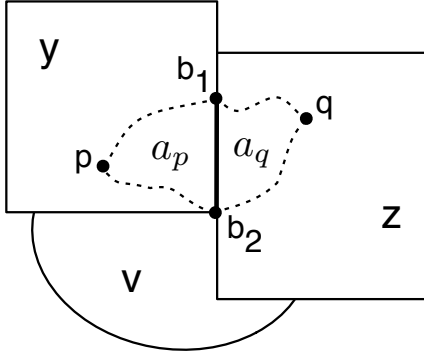

Figure 2: Construction of region z^I in proof of proposition (A11) in Lemma 5.

(A11): (As anticipated, this proof assumes the space has dimension 2. Nonetheless, *mutatis mutandis* the argument applies to any dimension $n \geq 2$.) If $x = U$ there is nothing to prove. Let $x \neq U$, $x = y + z$ and v^I be in the complement of x^I . Let $p \in y^I$ and $q \in z^I$. Since $SR(y + z)$, fix a connected part of the boundary of both y^I and z^I , call it \bar{b} . Since \mathbb{R}^2 is path-connected and y^I, z^I are open, let \bar{p}_{b_1} and \bar{p}_{b_2} be paths in y^I from p to the endpoints b_1 and b_2 of \bar{b} , respectively (Fig. 2). We can choose \bar{p}_{b_1} and \bar{p}_{b_2} so that they intersect neither each other nor the boundaries of y^I and z^I except for \bar{p}_{b_1} at b_1 and for \bar{p}_{b_2} at b_2 . We proceed analogously with q and $\bar{q}_{b_1}, \bar{q}_{b_2}$. Let a_p be the subregion of y^I with boundary $\bar{p}_{b_1}, \bar{p}_{b_2}, \bar{b}$. Let a_q be the subregion of z^I with boundary $\bar{q}_{b_1}, \bar{q}_{b_2}, \bar{b}$. By construction a_p and a_q are simple regions and so is region u^I given by the interior of the closure of $a_p \cup a_q$. Clearly, u^I is contained in $(y + z)^I$, properly overlaps both y^I and z^I , and its closure has at most two points in common with the boundary of v , namely b_1 and b_2 . Thus, for any v not overlapping x , $(u + v)^I$ is not a simple region. \square

THEOREM. *The axiomatic system (A1)–(A11) is consistent and has models $ROS(\mathbb{R}^n)$, $ROP(\mathbb{R}^n)$, $ROQ(\mathbb{R}^n)$, $RO(\mathbb{R}^n)$.*

6 Conclusions and Future Work

This paper presented a study of the notion of connection in mereological systems. It contributed to this line of research by providing the axiomatization of a mereotopological theory in which the mereological and the topological layers are independent of the notion of point both at the syntactic and at the semantic level.

We argued that the theory here presented is better suited to model spatial information from a cognitive viewpoint. Our arguments are at the moment just speculative and follow the discussion in the literature that led to the adoption of mereotopology for spatial knowledge as opposed to classical geometrical approaches. Differently from other studies, we apply these very arguments to all levels of the formalization thus including also the semantic aspects of the theory. This means that the theory does not refer to points and can be understood without even understanding what points are.

Recent studies have shown that elements of Euclidean geometry match by and large with human intuition about space [Izard *et al.*, 2011] but it is still unclear which structure(s) humans (and animals) apply to select, organize and manipulate spatial information [Spelke *et al.*, 2010]. While the present paper looks only at the theoretical and logical aspects of a mereotopological theory, it is motivated by the need to develop (conceptually and formally) spatial theories that support alternative views on the organization of spatial information and give new tools to cognitive scientists to study human perception and understanding of space.

In the future we aim to improve the set of axioms we proposed in this paper. Although these axioms capture key properties of our primitives, more work is needed to understand how the mereological, topological and geometrical layers interact in these systems. We are also considering how to organize psychological experiments, e.g. via pictures like those depicted in Fig. 1, to verify the cognitive relevance of the distinction between simple vs point-connected regions.

References

- [Borgo and Masolo, 2010] Stefano Borgo and Claudio Masolo. Full mereogeometries. *The Review of Symbolic Logic*, 3(4):521–567, 2010.
- [Borgo *et al.*, 1996] Stefano Borgo, Nicola Guarino, and Claudio Masolo. A pointless theory of space based on strong connection and congruence. In L. Carlucci Aiello, J. Doyle, and S.C. Shapiro, editors, *International Conference on Principles of Knowledge Representation and Reasoning (KR'96)*, pages 220–229, Boston, MA, 1996. Morgan Kaufmann.
- [Borgo, 2013] Stefano Borgo. RCC and the Theory of Simple Regions in R^2 . In Thora Tenbrink and John Stell, editors, *Spatial Information Theory - Cognitive and Computational Foundations of Geographic Information Science. Proceedings of International Conference COSIT '13*, LNCS 8116, pages 457–474, Springer Verlag, Berlin, 2013.
- [Casati and Varzi, 1999] Roberto Casati and Achille C. Varzi. *Parts and Places. The Structure of Spatial Representation*. MIT Press, Cambridge, MA, 1999.
- [Clarke, 1981] Bowman L. Clarke. A calculus of individuals based on connection. *Notre Dame Journal of Formal Logic*, 22:204–218, 1981.
- [Cohn and Renz, 2007] Anthony G. Cohn and Jochen Renz. Qualitative spatial representation and reasoning. In F. *et al* van Harmelen, editor, *Handbook of Knowledge Representation*, pages 551–596. Elsevier, 2007.
- [Dugat *et al.*, 1999] Vincent Dugat, Pierre Gambarotto, and Yannick Larvor. Qualitative theory of shape and structure. *Progress in Artificial Intelligence*, pages 850–850, 1999.
- [Eschenbach and Heydrich, 1995] Carola Eschenbach and Wolfgang Heydrich. Classical mereology and restricted domains. *International Journal Of Human-Computer Studies*, 43:723–740, 1995.

- [Eschenbach, 1999] Carola Eschenbach. A predication calculus for qualitative spatial representations. In Christian Freksa and David M. Mark, editors, *Spatial Information Theory. Cognitive and Computational Foundations of Geographic Information Science*, volume 1661 of *Lecture Notes in Computer Science*, pages 157–172. Springer Berlin Heidelberg, 1999.
- [Gerla, 1995] Giangiacomo Gerla. Pointless geometries. In F. Buekenhout, editor, *Handbook of Incidence Geometry*, pages 1015–1031. Elsevier, 1995.
- [Gotts, 1994] Nicholas M. Gotts. How far can we 'C'? defining a 'doughnut' using connection alone. In *Principles of Knowledge Representation and Reasoning: Proceedings of the 4th International Conference (KR94)*. Morgan Kaufmann, 1994.
- [Grzegorzczuk, 1960] Andrzej Grzegorzczuk. Axiomatizability of geometry without points. *Synthese*, 12:228–235, 1960.
- [Izard *et al.*, 2011] Veronique Izard, Pierre Pica, Elizabeth S Spelke, and Stanislas Dehaene. Flexible intuitions of Euclidean geometry in an Amazonian indigene group. *PNAS*, pages 1–6, May 2011.
- [Masolo and Vieu, 1999] Claudio Masolo and Laure Vieu. Atomicity vs. infinite divisibility of space. In Christian Freksa and David M. Mark, editors, *International Conference on Spatial Information Theory (COSIT '99)*, Lecture Notes in Computer Science, pages 235–250, London, UK, 1999. Springer-Verlag.
- [Munkres, 2000] James R. Munkres. *Topology*. Prentice Hall, 2nd edition, 2000.
- [Pratt-Hartmann and Schoop, 2002] Ian Pratt-Hartmann and Dominik Schoop. Elementary polyhedral mereotopology. *Journal of Philosophical Logic*, 31:469–498, 2002.
- [Pratt-Hartmann, 2007] Ian Pratt-Hartmann. First-order mereotopology. In Marco Aiello, Ian Pratt-Hartmann, and Johan van Benthem, editors, *Handbook of Spatial Logics*, pages 13–97. Springer, 2007.
- [Randell *et al.*, 1992] David A. Randell, Zhan Cui, and Anthony G. Cohn. A spatial logic based on regions and connections. In B. Nebel, C. Rich, and W. Swartout, editors, *International Conference on Principles of Knowledge Representation and Reasoning (KR'92)*, pages 165–176. Morgan Kaufmann, 1992.
- [Simons, 1987] Peter Simons. *Parts: a Study in Ontology*. Clarendon Press, Oxford, Oxford, 1987.
- [Spelke *et al.*, 2010] Elizabeth Spelke, Sang Ah Lee, and Véronique Izard. Beyond core knowledge: Natural geometry. *Cognitive Science*, 34(5):863–884, 2010.
- [Thompson and Oosterom, 2009] Rodney James Thompson and Peter Oosterom. Connectivity in the regular polytope representation. *GeoInformatica*, 15(2):223–246, October 2009.
- [Varzi, 2007] Achille C. Varzi. Spatial reasoning and ontology: Parts, wholes, and locations. In Marco Aiello, Ian Pratt-Hartmann, and Johan van Benthem, editors, *Handbook of Spatial Logics*, pages 945–1038. Springer, 2007.
- [Whitehead, 1929] Alfred North N. Whitehead. *Process and Reality. An Essay in Cosmology*. Macmillan, 1929.

A First-Order Axiomatization of Change in Mereotopology

Bahar Aameri

Department of Computer Science
University of Toronto
bahar@cs.toronto.edu

Michael Gruninger

Department of Mechanical and Industrial Engineering
University of Toronto
gruninger@mie.utoronto.ca

Abstract

The basic assumption in Qualitative Spatial Representation is that the commonsense conception of change is continuous. Therefore, to enable reasoning about change, a commonsense theory of space should include an axiomatic description for continuous change. In this paper, we introduce a sound and complete process ontology which enables reasoning about action and change within the Region Connection Calculus (RCC). We then apply the taxonomy of spatial changes, specified by the process ontology, to establish a model-theoretical and a first-order definition for continuous transition between RCC8 relations. Finally, we reconstruct the conceptual neighborhood graph for the RCC8 relations based on the proposed axiomatic description of continuity.

1 Introduction

The notion of change is a fundamental concept in the characterization of any physical system including spatial domains. In addition to a qualitative theory of space, a commonsense framework for automatic spatial reasoning requires an axiomatic theory which enables reasoning about change and action within the spatial domain. Besides, to guarantee the soundness and consistency of the spatial action theory, it needs to be verified with respect to the properties of the models of the spatial domain. Although qualitative spatial change has been studied in various contexts [Galton, 2000], an adequate axiomatization of dynamic spatial environments has not yet been presented; in particular both domain-specific theories, like [Bhatt *et al.*, 2006; Cabalar and Santos, 2011; Dylla and Moratz, 2004], and general approaches, such as [Bhatt and Loke, 2008; Grenon and Smith, 2004], are short on providing a formal method for verification of resulting theories.

One of the well-established representations for qualitative space is a mereotopological theory called the Region Connection Calculus (RCC) [Randell *et al.*, 1992]. We introduce a process ontology which enables reasoning about action and change within the RCC and verify the ontology by characterizing the models of the axioms up to isomorphism [Gruninger *et al.*, 2010].

A widespread assumption in Qualitative Spatial Representation is that the commonsense conception of change is continuous; consequently, most attempts for representing spatial change are focused on finding a description for continuous transitions between spatial relations [Galton, 1995; Muller, 1998; Davis, 2001; Hazarika and Cohn, 2001]. The notion of *conceptual neighborhood* [Freksa, 1991] is usually employed as the semantic basis for identifying continuous transitions [Dylla and Wallgrün, 2007; Zimmermann and Freksa, 1993; Zimmermann, 1993]. Within a particular spatial domain, all possible continuous transitions can be demonstrated by a transition graph [Hazarika, 2005], also known as *Conceptual Neighborhood Graph (CNG)*, where each vertex of the graph is associated with a primitive relation and edges express continuous transitions. Conceptual neighborhood graphs are usually applied as state constraints either to identify precondition and successor state axioms in an spatial action theory [Dylla and Moratz, 2004] or to build qualitative spatial simulators [Cui *et al.*, 1992].

Initially, Freksa introduced the idea of conceptual neighborhood for the purpose of temporal reasoning based on Allen's interval algebra [Allen, 1983]. He described two interval relations as conceptual neighbors "*if they can be directly transformed into one another by continuous deformation (shortening or lengthening) of the events intervals*" [Freksa, 1991]. This definition was later generalized to: "*Two relations are conceptual neighbors if a direct transition from one relation to the other can occur upon an arbitrarily small change in the referenced domain*" [Freksa, 1992]. The idea of conceptual neighborhood is powerful enough to be employed in any qualitative domain including the RCC. However, the definition suggested by Freksa for the general case is vague; in particular, it is not clear what should be considered as a "*small change*" within an arbitrary domain.

[Randell *et al.*, 1992] introduced an intuitive CNG for RCC8 relations (depicted in Figure 5) based on the CNG provided in [Freksa, 1991] for relations in the Allen's interval algebra. Several attempts have been made to reconstruct this diagram on a formal basis [Egenhofer and Al-Taha, 1992; Galton, 1995; Muller, 1998; Hazarika, 2005], but none of the reconstructed diagrams are identical to the original RCC8 CNG. [Hazarika and Cohn, 2001] presented an axiomatic definition for continuity in transitions between the RCC relations, and then partially recovered the RCC8 CNG by proving

that missing links are non-continuous. However, as pointed in [Hazarika, 2005], justification of the existing links requires a model-theoretical verification of the continuity theory with respect to some class of intended models.

One of the focuses in the current paper is to find an axiomatic definition for qualitative continuous changes within the RCC. We use the notion of *minimal change* in a domain to both interpret Freksa’s “*small change*”, as well as to characterize continuous transitions. In characterizing the minimal changes we consider the mereotopological properties rather than using geometrical metrics [Galton, 2000; Davis, 2001], as the RCC theory is a mereotopology. Unlike the definitions presented by [Muller, 1998] and [Hazarika and Cohn, 2001], the proposed definition can characterize continuous transitions in domains with discrete models of space or time. Moreover, we verify the soundness of our axiomatic definition with respect to the model-theoretical properties of the RCC axioms which enables us to justify the existing links of the RCC8 conceptual neighborhood graph.

In Section 3, we develop a first-order process ontology for the RCC based on the design methodology presented in [Aameri, 2012]; we characterize the models of the ontology up to isomorphism, and show that the ontology is sound, i.e., the effects of activity classes preserve domain constraints, and complete, i.e., the process ontology specifies all possible ways of changing states with regard to domain constraints. The methodology assists in a model characterization for change within the corresponding domain and provides a guideline for identifying all classes of activities that are possible within the domain. The activity classes lead us to a definition for the continuous transitions between the models of the RCC8 relations. In Section 4, we apply this continuity definition to axiomatize the notion of continuous change within the RCC8 theory and reconstruct the corresponding conceptual neighborhood graph. The RCC process ontology together with the axiomatic description of continuity forms a sound and complete formal theory which allows reasoning about change and action within the RCC domain.

2 Continuous Transitions in RCC8 Models

RCC is a first-order axiomatization of mereotopology¹ which considers the notion of connection as its primitive relation and defined parthood in terms of connection. RCC8 is a subtheory of the RCC that includes a set of eight Jointly Exhaustive and Pairwise Disjoint (JEPD) relations, namely *DC*, *EC*, *PO*, *EQ*, *TPP*, *NTPP* and inverses of the last two indicated by *TPPi* and *NTPPi*. A transformation between two spatial relations called a *transition*. We adopt the notation $\mathbf{R}_1 \leftrightarrow \mathbf{R}_2$, introduced by [Muller, 1998], to indicate the transition between two relations \mathbf{R}_1 and \mathbf{R}_2 .

[Stell, 1999] showed that strict models of the RCC axioms are equivalent to a class of structures called Boolean Connection Algebras (BCAs). A structure $\langle \mathcal{B}; \mathcal{C} \rangle^2$ is said to be a

¹The full axiomatization for the RCC Ontology can be found at <http://colore.oor.net/mereotopology/rcc.clif>

²We denote structures by calligraphic font: $\mathcal{M}, \mathcal{N}, \dots$, classes of structures by fraktur font: $\mathfrak{M}, \mathfrak{N}, \dots$, the domain of a structure \mathcal{M} by M , elements of a structure by **boldface** font , e.g. $\mathbf{a}, \mathbf{b}, \mathbf{c}$, and

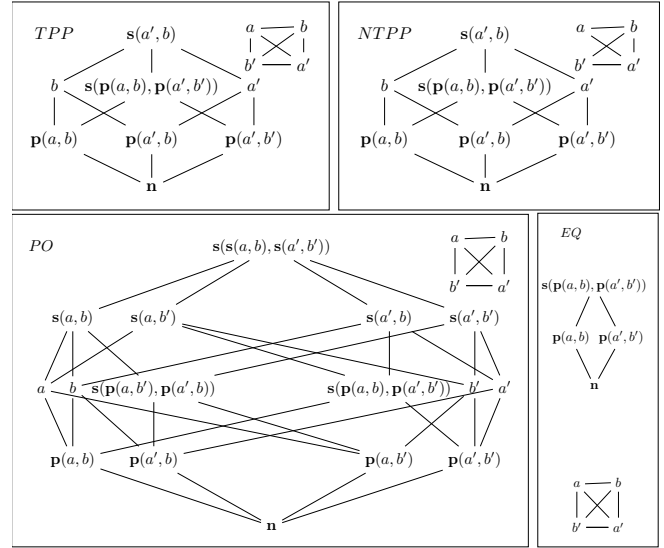

Figure 1: Models of *TPP*, *NTPP*, *PO* and *EQ* Relations.

BCA iff \mathcal{B} be a Boolean algebra and \mathcal{C} be a binary connection relation over elements of \mathcal{B} . Furthermore, one can define a Boolean lattice $\langle \mathbf{R} \cup \{\mathbf{n}\}; \mathbf{n}, \mathbf{u}, \mathbf{t}, \mathbf{s}, \mathbf{p} \rangle$, where \mathbf{R} is a set of regions, \mathbf{n}, \mathbf{u} are the null and universal regions resp., and $\mathbf{t}, \mathbf{s}, \mathbf{p}$ are the complement, sum and product operations over regions resp. Since connection relations can be represented by an undirected graph, a BCA is equivalent to the structure $\mathcal{B}_n \cup \mathcal{C}$, where \mathcal{B}_n is a n -atom Boolean lattice and \mathcal{C} is a connection graph.

Consider an RCC model in which an RCC8 relation \mathbf{R} holds between two arbitrary regions \mathbf{a}, \mathbf{b} . Since RCC8 is a subtheory of RCC, we can associate $\mathbf{R} \upharpoonright_{\{\mathbf{a}, \mathbf{b}\}}$ with the substructure of the RCC model that corresponds to \mathbf{a} and \mathbf{b} . Accordingly, we can define two mappings from an RCC8 relation to the Boolean lattice \mathcal{B}_n (n denotes the number of atoms) and connection graph \mathcal{C} . The first mapping is $\varphi_{\mathcal{B}} : \mathbf{R} \upharpoonright_{\{\mathbf{a}, \mathbf{b}\}} \rightarrow \langle H \rangle$, where $\langle H \rangle$ is the sublattice of \mathcal{B}_n induced by $H = \{\mathbf{p}(\mathbf{a}, \mathbf{b}), \mathbf{p}(\mathbf{a}', \mathbf{b}), \mathbf{p}(\mathbf{a}, \mathbf{b}'), \mathbf{p}(\mathbf{a}', \mathbf{b}')\}$. The second mapping is $\varphi_{\mathcal{C}} : \mathbf{R} \upharpoonright_{\{\mathbf{a}, \mathbf{b}\}} \rightarrow \langle G \rangle$, where G is the subgraph of \mathcal{C} that induced by the set $\{\mathbf{a}, \mathbf{b}, \mathbf{a}', \mathbf{b}'\}$.

Lemma 1 *Let \mathcal{M} be a model of RCC.*

Let $At(\mathcal{B})$ be the set of atoms of a Boolean lattice \mathcal{B} .

For two RCC8 relations $\mathbf{R}_1, \mathbf{R}_2$ and regions \mathbf{a}, \mathbf{b} in \mathcal{M} we have

1. *the set of atoms of a Boolean lattice associated with a RCC8 relation is a subset of H_A :*

$$At(\varphi_{\mathcal{B}}(\mathbf{R}_1 \upharpoonright_{\{\mathbf{a}, \mathbf{b}\}})) \subseteq H_A,$$

2. *the Boolean lattices associated with \mathbf{R}_1 and \mathbf{R}_2 are equal iff the sets of their atoms are equal:*

$$\varphi_{\mathcal{B}}(\mathbf{R}_1 \upharpoonright_{\{\mathbf{a}, \mathbf{b}\}}) = \varphi_{\mathcal{B}}(\mathbf{R}_2 \upharpoonright_{\{\mathbf{a}, \mathbf{b}\}}) \text{ iff } At(\varphi_{\mathcal{B}}(\mathbf{R}_1 \upharpoonright_{\{\mathbf{a}, \mathbf{b}\}})) = At(\varphi_{\mathcal{B}}(\mathbf{R}_2 \upharpoonright_{\{\mathbf{a}, \mathbf{b}\}})).$$

As can be seen in Figure 1, the transitions $PO \leftrightarrow TPP$, $EQ \leftrightarrow TPP$, and $TPP \leftrightarrow NTPP$ change either the extension of relation \mathbf{R} in a structure \mathcal{M} by $\langle \mathbf{a}_1, \dots, \mathbf{a}_i \rangle \in \mathbf{R}$.

Boolean lattice or the connection graph, while the transition $EQ \leftrightarrow NTPP$ changes both. However, this observation is inconsistent with the RCC8 CNG; all the above four transitions are considered continuous in the CNG, but the first three transitions make “*smaller change*” compared to the fourth transition. Thus, according to our interpretation of the Freksa’s definition, the transition between EQ and $NTPP$ is not continuous.

As the above observation illustrates, to justify edges of the CNG we should first identify the minimal changes within the RCC8 models. Since the CNG demonstrates *all* continuous transitions, we need to identify *all* minimal changes that are possible in the domain. In the next section we first develop the RCC Process Ontology which provides a complete taxonomy of *all* possible changes within spatial domains axiomatized by the RCC. The taxonomy can then be employed to identify all minimal changes.

3 RCC Process Ontology

For designing the RCC Process Ontology, we will follow the methodology introduced in [Aameri, 2012]. Through four main steps, the methodology provides a trivial routine for axiomatization of domain constraints as well as a mathematically rigorous procedure for identifying a complete taxonomy of domain activities. The methodology starts by identifying a theory, called *Domain Ontology*, which axiomatizes relations among continuants of the domain independent of the notion of change, then extends the domain ontology by a generic process ontology, like Process Specification Language (PSL) [Gruninger, 2003], and characterizes the models of the resulted theory. In the third step, all possible activity classes are characterized using the partial automorphisms of the models of the domain ontology and an algebraic structure called scaffold. Finally, in step four, the activity classes are axiomatized.

The taxonomy of the activity classes will be crucial in determining minimal changes, since a small change is the result of an activity occurrence that is a member of exactly one of the activity classes in the taxonomy. If we examine the effects of activity classes, compare the effects, and identify minimal effects, we can be sure that a smaller change than those that are already specified is not possible within the domain. Note that in some domains more than one type of small change is possible, i.e., there is no *minimum* change, and therefore we should identify all possible *minimal* changes.

The final theory would be a modular ontology that can be reused in application domains with the same model-theoretic representation. In this section we first review properties of PSL that we use in the current paper and then explain the application of methodology to the RCC.

3.1 The PSL Ontology

The PSL Ontology is a set of formal theories, axiomatized in first-order language, which formalize the fundamental concepts of processes and the relationships among them³. PSL describes a process by specifying all possible sequence of activity occurrences. Given a set of activities, all possible oc-

³The full axiomatization for the PSL Ontology can be found at <http://www.mel.nist.gov/psl/psl-ontology>.

Predicate	Interpretation
$arboreal(\mathbf{o})$	\mathbf{o} is an element of occurrence tree
$prior(\mathbf{f}, \mathbf{o})$	Fluent \mathbf{f} holds before activity occurrence \mathbf{o}
$holds(\mathbf{f}, \mathbf{o})$	Fluent \mathbf{f} holds after activity occurrence \mathbf{o}
$achieves(\mathbf{o}, \mathbf{f})$	$\neg prior(\mathbf{f}, \mathbf{o}) \wedge holds(\mathbf{f}, \mathbf{o})$
$falsifies(\mathbf{o}, \mathbf{f})$	$prior(\mathbf{f}, \mathbf{o}) \wedge \neg holds(\mathbf{f}, \mathbf{o})$
$changes(\mathbf{o}, \mathbf{f})$	$achieves(\mathbf{o}, \mathbf{f}) \vee falsifies(\mathbf{o}, \mathbf{f})$

Table 1: PSL Predicates

currences of atomic activities are represented through a partially ordered set of activity occurrences. Each ordered set is demonstrated as an *occurrence tree*, Γ , such that an initial occurrence is the root and sequences of activity occurrences are branches of the tree. Table 1 shows PSL predicates which we use in this paper and their interpretations.

Within the PSL Ontology, states are demonstrated by sets of reified fluents. Each activity occurrence \mathbf{o} is associated with two sets of fluents, $\Sigma(\mathbf{o}) = \{\mathbf{f} : \langle \mathbf{f}, \mathbf{o} \rangle \in \mathbf{prior}\}$ and $\Pi(\mathbf{o}) = \{\mathbf{f} : \langle \mathbf{f}, \mathbf{o} \rangle \in \mathbf{holds}\}$, where $\Sigma(\mathbf{o})$ describes the state before the occurrence of \mathbf{o} and $\Pi(\mathbf{o})$ describes the state after the occurrence of \mathbf{o} . Only an activity occurrence can change a fluent. Therefore, if an activity occurrence \mathbf{o}_2 be a successor of another activity occurrence \mathbf{o}_1 , then we have $\Sigma(\mathbf{o}_2) = \Pi(\mathbf{o}_1)$ as no activity has occurred between \mathbf{o}_1 and \mathbf{o}_2 . Moreover, a change in state can be represented by the set of fluents that changed due to an activity occurrence.

3.2 Design of the RCC Process Ontology

In applying the methodology of [Aameri, 2012], we treat T_{rcc} (RCC theory) as the domain ontology. We translate T_{rcc} into a set of state constraints T_{strcc} , in which all of the relations in T_{rcc} are mapped to fluents, e.g., axioms 2 and 3 in Figure 2 are the translations of the axioms in T_{rcc} which define the parthood and the overlap relations⁴. Given a model \mathcal{N} of RCC and a model \mathcal{M} of T_{strcc} , for each relation \mathbf{R}_i in \mathcal{N} , there is a bijection θ_{R_i} which maps each tuple $\langle \mathbf{a}, \mathbf{b} \rangle$ in \mathbf{R}_i to a fluent $\mathbf{F}_i(\mathbf{a}, \mathbf{b})$ in \mathcal{M} , i.e.

$$\theta_{R_i}(\langle \mathbf{a}, \mathbf{b} \rangle^{\mathcal{N}}) = \mathbf{F}_i^{\mathcal{M}}(\mathbf{a}, \mathbf{b}).$$

In particular, the pairs of elements $\langle \mathbf{x}, \mathbf{y} \rangle$ in the extension of the parthood relation are mapped to the fluent $\mathbf{P}_s(\mathbf{x}, \mathbf{y})$, and the pairs of elements $\langle \mathbf{x}, \mathbf{y} \rangle$ in the extension of the overlaps relation are mapped to the fluent $\mathbf{O}_s(\mathbf{x}, \mathbf{y})$.

Using these mappings, each activity occurrence in the occurrence tree Γ in a model of T_{strcc} is associated with two models of T_{rcc} :

- there is a mapping $\mu : \Gamma \rightarrow Mod(T_{rcc})$ such that

$$\langle \theta_{R_i}(\langle \mathbf{x}, \mathbf{y} \rangle), \mathbf{o} \rangle \in \mathbf{prior} \Leftrightarrow \langle \mathbf{x}, \mathbf{y} \rangle \in \mathbf{R}_i^{\mu(\mathbf{o})}$$

- there is a mapping $\eta : \Gamma \rightarrow Mod(T_{rcc})$ such that

$$\langle \theta_{R_i}(\langle \mathbf{x}, \mathbf{y} \rangle), \mathbf{o} \rangle \in \mathbf{holds} \Leftrightarrow \langle \mathbf{x}, \mathbf{y} \rangle \in \mathbf{R}_i^{\eta(\mathbf{o})}$$

As [Aameri, 2012] showed, the notion of partial isomorphisms between models of the domain ontology (in our case T_{rcc}) can be used to characterize the fluents that are preserved by the corresponding activity occurrences.

⁴The complete set of axioms can be found at

<http://colore.oor.net/rcc%5Fcontinuous%5Fprocess/rcc%5Fstate.clif>

$$\begin{aligned}
& (\forall x, y, o) \text{arboreal}(o) \wedge \text{prior}(\text{connect}(x, y), o) & (1) \\
& \quad \supset \text{prior}(\text{region}(x), o) \wedge \text{prior}(\text{region}(y), o) \\
& (\forall x, y, o) \text{prior}(P_s(x, y), o) \equiv (\text{arboreal}(o) & (2) \\
& \quad \wedge \text{prior}(\text{region}(x), o) \wedge \text{prior}(\text{region}(y), o) \wedge \\
& (\forall z) \text{prior}(\text{connect}(z, x), o) \supset \text{prior}(\text{connect}(z, y), o)) \\
& (\forall x, y, o) \text{prior}(O_s(x, y), o) \equiv (\text{arboreal}(o) & (3) \\
& \quad \wedge (\exists z) \text{prior}(P_s(z, x), o) \wedge \text{prior}(P_s(z, y), o))
\end{aligned}$$

Figure 2: Axioms for the RCC State Ontology T_{strcc} .

Definition 1 Let $\mathcal{M}_1, \mathcal{M}_2$ be structures with signature L . An injective mapping $\varphi : \mathcal{M}_1 \rightarrow \mathcal{M}_2$ is a partial isomorphism restricted to some reduction L^- of L iff for all relations $\mathbf{R} \in L^-$

$$\langle \mathbf{x}_1, \dots, \mathbf{x}_n \rangle \in \mathbf{R}^{\mathcal{M}_1} \text{ iff } \langle \varphi(\mathbf{x}_1), \dots, \varphi(\mathbf{x}_n) \rangle \in \mathbf{R}^{\mathcal{M}_2}.$$

A mapping $\varphi : \mathcal{M} \rightarrow \mathcal{M}$ is a restricted partial automorphism iff it is an restricted isomorphism between substructures of \mathcal{M} .

For a structure \mathcal{M} , the set of all partial automorphism $PAut(\mathcal{M})$ forms an inverse semigroup [Ganyushkin and Mazorchuk, 2009]. In universal algebras, the lattice of the substructures of a structure \mathcal{M} is isomorphic to the lattice of the idempotents⁵ of $PAut(\mathcal{M})$ [Bredikhin, 1976]. So each substructure corresponds to an idempotent. Note that since $PAut(\mathcal{M})$ is an inverse semigroup its idempotents are actually partial identities of \mathcal{M} [Lawson, 1998]. On the other hand, each activity occurrence partitions the domain of the corresponding models into two or more invariant substructures. Therefore, to characterize an activity occurrence it is sufficient to identify the corresponding idempotents, i.e., the identity mappings of the invariant substructures. [Ganyushkin and Mazorchuk, 2009] show that each idempotent is associated with a unique subgroup of $PAut(\mathcal{M})$. In the other words, the respective subgroup, G_e , of an idempotent e , is the automorphism group of the substructure corresponded to e , and thus, all mappings that preserve the substructure are included in G_e .

[Aameri, 2012] introduced the notion of scaffold to represent all invariant substructures associated to an activity occurrence. A scaffold \mathfrak{G}_o^L includes sets of all restricted partial automorphisms of maximal common substructures of $\mathcal{M}_{\Sigma(o)}$ and $\mathcal{M}_{\Pi(o)}$ with respect to a specific reduction L . Note that a scaffold is a set, because there might be more than one partitions of maximal invariant substructures associated with an activity occurrence.

Definition 2 Let \mathcal{N} be a model of a domain state ontology.

A scaffold \mathfrak{G}_o^L of an activity occurrence $\mathbf{o} \in \Gamma$ is a set consisting of all sets \mathbb{G}_i of subgroups of $PAut(\mathcal{M}_{\Sigma(o)})$, which preserve relations in L , such that for all $\mathbb{G}_i \in \mathfrak{G}_o^L$

1. All $G_{ij} \in \mathbb{G}_i$ be maximal subgroups of $PAut(\mathcal{M}_{\Sigma(o)})$, s.t. their identity elements e_{ij} are idempotents associated with invariant substructures (with respect to L) of $\mathcal{M}_{\Sigma(o)}$ and $\mathcal{M}_{\Pi(o)}$;

⁵An idempotent is an element x such that $(x \cdot x) = x$.

2. The identity element e_{ij} of each $G_{ij} \in \mathbb{G}_i$ has a maximal domain; that is, there is no other identity mapping e' that satisfies property 1 and $\text{dom}(e_{ij}) \subset \text{dom}(e')$;
3. If $\mathbb{G}_i = \{G_{i1}, \dots, G_{im}\}$ then $\text{dom}(e_{i1}) \cup \dots \cup \text{dom}(e_{im}) = \text{dom}(\mathcal{M}_{\Sigma(o)})$ and $\text{dom}(e_{i1}) \cap \dots \cap \text{dom}(e_{im}) = \emptyset$.

Suppose an activity occurrence \mathbf{o} changes the relation between two regions \mathbf{a}, \mathbf{b} from TPP to $NTPP$. So it only changes the connection relation between \mathbf{a} and \mathbf{b}' (see Figure 1). Then the scaffold $\mathfrak{G}_o^{\text{connect}}$, associated with \mathbf{o} and connect , is equal to $\{\{G_{11}, G_{12}\}, \{G_{21}, G_{22}\}\}$, where $G_{11}, G_{12}, G_{21}, G_{22}$ are maximal subgroups generated by identity mappings $e_{11}, e_{12}, e_{21}, e_{22}$ resp., and we have $\text{dom}(e_{11}) = \{a, b, a'\}$, $\text{dom}(e_{12}) = \{b'\}$, $\text{dom}(e_{21}) = \{b, a', b'\}$ and $\text{dom}(e_{22}) = \{a\}$.

The interesting property of the scaffold is that we can extract all changes made by an activity occurrence \mathbf{o} to a specific relation from the corresponding scaffold. Since each set of mappings in a scaffold specifies an invariant substructure, if a relation between two elements be changed by \mathbf{o} , then the corresponding scaffold will not contain a mapping that have those elements in its domain. Thus, if two elements are in none of the mapping's domain of the scaffold, we can conclude that \mathbf{o} has changed the corresponding relation between them, and since the scaffold contains all maximal invariant substructures, it captures all the changes caused by \mathbf{o} .

In most domains more than one relation is needed to characterize a change in a model. The next theorem addresses the question of how many relations are needed to be able to characterize all possible changes in RCC (and equivalently all activity occurrences of RCC state ontology) up to isomorphism:

Theorem 1 Suppose $\mathcal{M} \in \text{Mod}(T_{strcc} \cup T_{psl})$.

For any activity occurrences $\mathbf{o}_1, \mathbf{o}_2 \in \Gamma$ if $\mu(\mathbf{o}_1) \cong \mu(\mathbf{o}_2)$, and

$$\begin{aligned}
\mathfrak{G}_{\mathbf{o}_1}^{\text{region}} &\cong \mathfrak{G}_{\mathbf{o}_2}^{\text{region}} \text{ and} \\
\mathfrak{G}_{\mathbf{o}_1}^{\text{connect}} &\cong \mathfrak{G}_{\mathbf{o}_2}^{\text{connect}}
\end{aligned}$$

then $\eta(\mathbf{o}_1) \cong \eta(\mathbf{o}_2)$.

Intuitively speaking, Theorem 1 demonstrates that any change within the RCC domains can be expressed in terms of change-in-regions (i.e. merging or splinting regions) and change-in-connections (i.e. achieving or falsifying connection relations). Therefore, all possible activities in the RCC domain fall within at least one of the above types.

Definition 3 $\mathfrak{M}^{\text{rccprocess}}$ is the class of structures such that $\mathcal{M} \in \mathfrak{M}^{\text{rccprocess}}$ iff

1. there exists $\mathcal{N} \in \mathfrak{M}^{\text{strcc}}$ such that $\mathcal{N} \subset \mathcal{M}$,
2. for all $\mathbf{o} \in \Gamma$, $\mathfrak{G}_o^{\text{region}} \neq \mathcal{I}$ or $\mathfrak{G}_o^{\text{connect}} \neq \mathcal{I}$, where $\mathcal{I} = \{\{I_\mu\}\}$, I_μ denotes the identity mapping over $\mu(\mathbf{o})$,
3. $\langle \mathbf{a} \rangle \in \text{preserve_region}$ iff for every occurrence \mathbf{o} of the activity \mathbf{a} , $\mathfrak{G}_o^{\text{region}} = \mathcal{I}$,
4. $\langle \mathbf{a} \rangle \in \text{change_region}$ iff for every occurrence \mathbf{o} of the activity \mathbf{a} , $\mathfrak{G}_o^{\text{region}} \neq \mathcal{I}$,
5. $\langle \mathbf{a} \rangle \in \text{preserve_connects}$ iff for every occurrence \mathbf{o} of the activity \mathbf{a} , $\mathfrak{G}_o^{\text{connect}} = \mathcal{I}$,

$$\begin{aligned}
(\forall o) arboreal(o) \supset (\exists x) changes(o, region(x)) & \quad (4) \\
\vee (\exists x, y) changes(o, connect(x, y)). & \\
(\forall a) preserve_region(a) \equiv ((\forall o, x) & \quad (5) \\
occurrence_of(o, a) \supset \neg changes(o, region(x))). & \\
(\forall a) change_region(a) \equiv ((\forall o) occurrence_of(o, a) & \quad (6) \\
\supset (\exists x) changes(o, region(x))). & \\
(\forall a) preserve_connect(a) \equiv ((\forall o, x, y) & \quad (7) \\
occurrence_of(o, a) \supset \neg changes(o, connect(x, y))). & \\
(\forall a) change_connect(a) \equiv ((\forall o) occurrence_of(o, a) & \quad (8) \\
\supset (\exists x, y) changes(o, connect(x, y))). &
\end{aligned}$$

Figure 3: Axioms for $T_{rccprocess}$.

6. $\langle \mathbf{a} \rangle \in \text{change_connects}$ iff for every occurrence \mathbf{o} of the activity \mathbf{a} , $\mathcal{G}_{\mathbf{o}}^{connect} \neq \mathcal{I}$.

The theory $T_{rccprocess}$ (Figure 3) axiomatizes activity classes in Definition 3:

4 Revisiting the Conceptual Neighborhood

Consider again the problem in Section 2 which motivated our work – identifying “smallest” possible changes in RCC8 models. As we stated in Section 3, all activities within models of T_{rcc} are instances of the *change_region* or *change_connect* class; thus, all transitions in the conceptual neighborhood graphs within the models can be achieved by activity occurrences of activities in these two classes. For example $TPP(x, y) \leftrightarrow TPPi(x, y)$ is caused by *change_region* activities while $DC(x, y) \leftrightarrow PO(x, y)$ is the result of both *change_region* and *change_connect* activities. This implies that activities which result in small changes either alter regions or connections, and not both. From the model-theoretic perspective, this means that small changes either modify the connection graph associated with a RCC8 relation, or alter the respective Boolean lattice. The smallest elements in a Boolean algebra are its atoms. Thus, a small change will only merge or split an atom in the corresponding Boolean lattice. As the vertices of a connection graph are fixed, adding or removing exactly one edge are the smallest possible changes in a connection graph. We, therefore, can define a continuous transition graph, called *continuous conceptual neighborhood*, as characterized in Definition 4.

Definition 4 Let $\mathcal{M} \in \mathfrak{M}^{rcc}$. An undirected graph $\mathcal{G} = \langle V, E \rangle$ is a *Continuous Conceptual Neighborhood (CCN) graph* for \mathcal{M} iff V is the set of all RCC8 relations and for all $\mathbf{R}_1, \mathbf{R}_2 \in V$, $(\mathbf{R}_1, \mathbf{R}_2) \in E$ iff all regions \mathbf{a}, \mathbf{b} in \mathcal{M} satisfy one of the following:

1. $\varphi_{\mathcal{B}}(\mathbf{R}_1 \upharpoonright_{\{\mathbf{a}, \mathbf{b}\}}) = \varphi_{\mathcal{B}}(\mathbf{R}_2 \upharpoonright_{\{\mathbf{a}, \mathbf{b}\}})$, and for some edge e

$$\varphi_{\mathcal{C}}(\mathbf{R}_2 \upharpoonright_{\{\mathbf{a}, \mathbf{b}\}}) = \varphi_{\mathcal{C}}(\mathbf{R}_1 \upharpoonright_{\{\mathbf{a}, \mathbf{b}\}}) + e^6,$$
2. $\varphi_{\mathcal{B}}(\mathbf{R}_1 \upharpoonright_{\{\mathbf{a}, \mathbf{b}\}}) = \varphi_{\mathcal{B}}(\mathbf{R}_2 \upharpoonright_{\{\mathbf{a}, \mathbf{b}\}})$, and for some edge e

$$\varphi_{\mathcal{C}}(\mathbf{R}_2 \upharpoonright_{\{\mathbf{a}, \mathbf{b}\}}) = \varphi_{\mathcal{C}}(\mathbf{R}_1 \upharpoonright_{\{\mathbf{a}, \mathbf{b}\}}) - e,$$

⁶For a graph $\mathcal{G} = \langle V, E \rangle$ and edge e , $\mathcal{G} + e = \langle V, E \cup \{e\} \rangle$ and $\mathcal{G} - e = \langle V, E \setminus \{e\} \rangle$.

$$\begin{aligned}
(\forall x, y, o) changes(o, connect(x, y)) \wedge & \quad (9) \\
(changes(o, connect(x', y)) \vee changes(o, connect(x, y'))) & \\
\vee changes(o, P_s(x, y)) \vee changes(o, P_s(y, x)) & \\
\vee changes(o, O_s(x, y)) & \\
\supset (changes(o, region(x)) \vee changes(o, region(y))) & \\
(\forall x, y, o) changes(o, connect(x', y)) \wedge & \quad (10) \\
(changes(o, connect(x, y')) \vee changes(o, O_s(x, y))) & \\
\vee changes(o, P_s(x, y)) \vee changes(o, P_s(y, x)) & \\
\supset (changes(o, region(x)) \vee changes(o, region(y))) & \\
(\forall x, y, o) changes(o, connect(x, y')) \wedge & \quad (11) \\
(changes(o, P_s(x, y)) \vee changes(o, P_s(y, x))) & \\
\vee changes(o, O_s(x, y)) & \\
\supset (changes(o, region(x)) \vee changes(o, region(y))) & \\
(\forall x, y, o) changes(o, O_s(x, y)) \wedge & \quad (12) \\
(changes(o, P_s(x, y)) \vee changes(o, P_s(y, x))) & \\
\supset (changes(o, region(x)) \vee changes(o, region(y))) & \\
(\forall x, y, o) changes(o, P_s(x, y)) \wedge changes(o, P_s(y, x)) & \quad (13) \\
\supset (changes(o, region(x)) \vee changes(o, region(y))) &
\end{aligned}$$

Figure 4: Axiom for $T_{continuous}$: for all regions x, y , an element of the occurrence tree o either changes at most one of the relations $connect(x, y)$, $connect(x', y)$, $connect(x, y')$, $O_s(x, y)$, $P_s(x, y)$ or $P_s(y, x)$, or it merges or splits x or y .

3. $\varphi_{\mathcal{C}}(\mathbf{R}_1 \upharpoonright_{\{\mathbf{a}, \mathbf{b}\}}) = \varphi_{\mathcal{C}}(\mathbf{R}_2 \upharpoonright_{\{\mathbf{a}, \mathbf{b}\}})$,
 $\mathcal{B}_n \cong \varphi_{\mathcal{B}}(\mathbf{R}_1 \upharpoonright_{\{\mathbf{a}, \mathbf{b}\}})$, $\mathcal{B}_{n+1} \cong \varphi_{\mathcal{B}}(\mathbf{R}_2 \upharpoonright_{\{\mathbf{a}, \mathbf{b}\}})$ and
 $\varphi_{\mathcal{B}}(\mathbf{R}_1 \upharpoonright_{\{\mathbf{a}, \mathbf{b}\}}) \subset \varphi_{\mathcal{B}}(\mathbf{R}_2 \upharpoonright_{\{\mathbf{a}, \mathbf{b}\}})$,
4. $\varphi_{\mathcal{C}}(\mathbf{R}_1 \upharpoonright_{\{\mathbf{a}, \mathbf{b}\}}) = \varphi_{\mathcal{C}}(\mathbf{R}_2 \upharpoonright_{\{\mathbf{a}, \mathbf{b}\}})$,
 $\mathcal{B}_{n+1} \cong \varphi_{\mathcal{B}}(\mathbf{R}_1 \upharpoonright_{\{\mathbf{a}, \mathbf{b}\}})$, $\mathcal{B}_n \cong \varphi_{\mathcal{B}}(\mathbf{R}_2 \upharpoonright_{\{\mathbf{a}, \mathbf{b}\}})$ and
 $\varphi_{\mathcal{B}}(\mathbf{R}_2 \upharpoonright_{\{\mathbf{a}, \mathbf{b}\}}) \subset \varphi_{\mathcal{B}}(\mathbf{R}_1 \upharpoonright_{\{\mathbf{a}, \mathbf{b}\}})$.

A transition $\mathbf{R}_1 \leftrightarrow \mathbf{R}_2$ is *continuous* iff $(\mathbf{R}_1, \mathbf{R}_2)$ is an edge of the CCN graph.

To illustrate this definition, consider the relations and their corresponding structures in Figure 1. $(\mathbf{NTPP}, \mathbf{TPP})$ is an edge in the CCN graph because for all regions \mathbf{a}, \mathbf{b} we have $\varphi_{\mathcal{B}}(\mathbf{TPP} \upharpoonright_{\{\mathbf{a}, \mathbf{b}\}}) = \varphi_{\mathcal{B}}(\mathbf{NTPP} \upharpoonright_{\{\mathbf{a}, \mathbf{b}\}})$, and $\varphi_{\mathcal{C}}(\mathbf{TPP} \upharpoonright_{\{\mathbf{a}, \mathbf{b}\}}) = \varphi_{\mathcal{C}}(\mathbf{NTPP} \upharpoonright_{\{\mathbf{a}, \mathbf{b}\}}) + (\mathbf{a}, \mathbf{b}')$. However, $(\mathbf{PO}, \mathbf{EQ})$ is not in the CCN graph since $\varphi_{\mathcal{B}}(\mathbf{PO} \upharpoonright_{\{\mathbf{a}, \mathbf{b}\}}) \cong \mathcal{B}_4$ and $\varphi_{\mathcal{B}}(\mathbf{EQ} \upharpoonright_{\{\mathbf{a}, \mathbf{b}\}}) \cong \mathcal{B}_2$.

Definition 5 $\mathfrak{M}^{continuous}$ is the class of structures such that $\mathcal{M} \in \mathfrak{M}^{continuous}$ iff

1. there exists $\mathcal{N} \in \mathfrak{M}^{rccprocess}$ such that $\mathcal{M} \subset \mathcal{N}$;
2. for all $\mathbf{o} \in \Gamma$ and all regions \mathbf{a}, \mathbf{b} , we have

$$\langle \mathbf{o}, \theta_{R_1}(\langle \mathbf{a}, \mathbf{b} \rangle) \rangle, \langle \mathbf{o}, \theta_{R_2}(\langle \mathbf{a}, \mathbf{b} \rangle) \rangle \in \text{changes}$$

then \mathbf{R}_1 and \mathbf{R}_2 are adjacent in the CCN graph.

Theorem 2 asserts that $T_{continuous}$ (Figure 4) provides an axiomatization of $\mathfrak{M}^{continuous}$, which formalizes continuous change in models of the RCC process ontology.

Theorem 2 \mathcal{M} is a model of $T_{rcccp} = T_{continuous} \cup T_{rccprocess} \cup T_{strcc} \cup T_{psl}$ iff it is isomorphic to a structure in $\mathfrak{M}^{continuous}$.

Proof. (Sketch) Using the definition of product, it can be verified that for two regions a, b , ($a, b \neq n, a, b \neq u$), we have

$$\begin{aligned} \langle n, p(a, b) \rangle \notin EQ &\text{ iff } \langle a, b \rangle \in O, \\ \langle n, p(a, b') \rangle \notin EQ &\text{ iff } \langle a, b \rangle \notin P, \\ \langle n, p(a', b) \rangle \notin EQ &\text{ iff } \langle b, a \rangle \notin P, \\ \langle n, p(a', b') \rangle \notin EQ. & \end{aligned}$$

Therefore, for two regions a, b , exactly one atom would be added or eliminated to the corresponding Boolean lattice iff either the overlap relation between a, b or the parthood relation between a, b or the parthood relation between b, a changes. Using Lemma 1, it is also straightforward to show that for two RCC8 relations R_1 and R_2 , $\varphi_B(R_1 \upharpoonright_{\{a,b\}}) \neq \varphi_B(R_2 \upharpoonright_{\{a,b\}})$ iff in the transition between R_1 and R_2 , $\theta_O(\langle a, b \rangle)$, $\theta_P(\langle a, b \rangle)$ or $\theta_P(\langle b, a \rangle)$ changes.

In the models of T_{rcc} a region is always connected to its complement, so $\varphi_C(\mathbf{R} \upharpoonright_{\{a,b\}})$ changes iff $\langle o, \theta_C(\langle a, b \rangle) \rangle$ or $\langle o, \theta_C(\langle a, b' \rangle) \rangle$ or $\langle o, \theta_C(\langle a', b \rangle) \rangle$ is in **changes**. Therefore, properties (1) and (2) in Definition 4 are satisfied iff

$\langle o, \theta_O(\langle a, b \rangle) \rangle, \langle o, \theta_P(\langle a, b \rangle) \rangle, \langle o, \theta_P(\langle b, a \rangle) \rangle \notin \text{changes}$ and exactly one of $\langle o, \theta_C(\langle a, b \rangle) \rangle$ or $\langle o, \theta_C(\langle a, b' \rangle) \rangle$ or $\langle o, \theta_C(\langle a', b \rangle) \rangle$ are in **changes**.

Now suppose property (3) in Definition 4 is satisfied by $\mathbf{R}_1^{\mu(o)} \upharpoonright_{\{a,b\}}$ and $\mathbf{R}_2^{\eta(o)} \upharpoonright_{\{a,b\}}$. The connection graphs are the same, so we have

$\langle o, \theta_C(\langle a, b \rangle) \rangle, \langle o, \theta_C(\langle a, b' \rangle) \rangle, \langle o, \theta_C(\langle a', b \rangle) \rangle \notin \text{changes}$
 Since $\mathcal{B}_n \cong \varphi_B(\mathbf{R}_1^{\mu(o)} \upharpoonright_{\{a,b\}})$, $\mathcal{B}_{n+1} \cong \varphi_B(\mathbf{R}_2^{\eta(o)} \upharpoonright_{\{a,b\}})$ and $\varphi_B(\mathbf{R}_1^{\mu(o)} \upharpoonright_{\{a,b\}}) \subset \varphi_B(\mathbf{R}_2^{\eta(o)} \upharpoonright_{\{a,b\}})$, we know that $At(\varphi_B(\mathbf{R}_1^{\mu(o)} \upharpoonright_{\{a,b\}})) \subset At(\varphi_B(\mathbf{R}_2^{\eta(o)} \upharpoonright_{\{a,b\}}))$ and they differ in exactly one element (Lemma 1). Therefore, exactly one of $\langle o, \theta_O(\langle a, b \rangle) \rangle, \langle o, \theta_P(\langle a, b \rangle) \rangle, \langle o, \theta_P(\langle b, a \rangle) \rangle$ are in **changes**. The proof for property (4) is similar.

For the other direction, suppose

$\langle o, \theta_C(\langle a, b \rangle) \rangle, \langle o, \theta_C(\langle a, b' \rangle) \rangle, \langle o, \theta_C(\langle a', b \rangle) \rangle \notin \text{changes}$ and exactly one of $\langle o, \theta_O(\langle a, b \rangle) \rangle, \langle o, \theta_P(\langle a, b \rangle) \rangle, \langle o, \theta_P(\langle b, a \rangle) \rangle$ be in **changes**.

Then, $At(\varphi_B(\mathbf{R}_1^{\mu(o)} \upharpoonright_{\{a,b\}}))$ and $At(\varphi_B(\mathbf{R}_2^{\eta(o)} \upharpoonright_{\{a,b\}}))$ differ in exactly one element. Using Lemma 1, it can be shown that in this case either property (3) or (4) is satisfied. \square

Finally, we can construct the CCN graph for the RCC8 relations based on Theorem 3.

Theorem 3 Let $\mathcal{M} \in \mathfrak{M}^{rcc}$ and $\mathcal{G} = \langle V, E \rangle$ be the CCN graph for \mathcal{M} . Then

$$\begin{aligned} E = \{ & (DC, EC), (EC, PO), \\ & (PO, TPP), (PO, TPPi), (EQ, TPP), \\ & (EQ, TPPi), (TPP, NTPP), (TPPi, NTPPi) \}. \end{aligned}$$

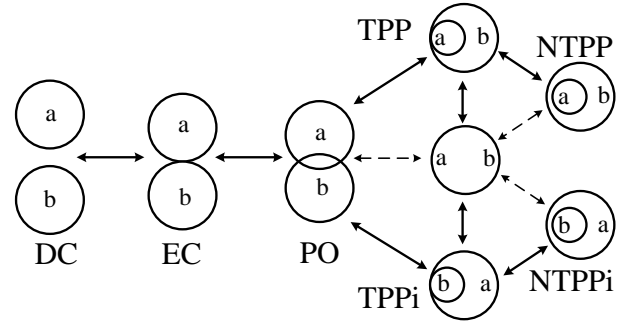

Figure 5: RCC8 CN (includes dashed lines) and CCN (solid lines) Graphs. Note that the current CCN is only applicable in domains which consider strict models of the RCC theory.

Proof. Using the automated theorem prover Prover9 [McCune, 2005 2010], we have shown⁷ that for all $R_1 \in V$, $(R_1, R_2), \dots, (R_1, R_n) \in E$ then

$$\begin{aligned} T_{rcccp} \models & (\forall x, y, o) \text{changes}(o, R_1(x, y)) \wedge \\ & \wedge \neg \text{changes}(o, \text{region}(x)) \wedge \neg \text{changes}(o, \text{region}(y)) \supset \\ & \text{changes}(o, R_2(x, y)) \vee \dots \vee \text{changes}(o, R_n(x, y)), \end{aligned}$$

and for all $(R'_1, R'_2) \notin E$ we have

$$\begin{aligned} T_{rcccp} \models & (\forall x, y, o) \text{changes}(o, R'_1(x, y)) \supset \\ & \neg \text{changes}(o, R'_2(x, y)). \quad \square \end{aligned}$$

5 Conclusion

Although the notion of conceptual neighborhood has been introduced as the semantic basis for identifying continuous transitions in spatial domains, it lacks an adequate axiomatization of the conditions that underly intuitions about continuous change. Furthermore, the relationship between the conceptual neighborhood and different theories for qualitative spatial reasoning is not clearly specified. In this paper, we have applied a methodology for designing first-order domain-specific process ontologies to provide a formal foundation for conceptual neighborhoods.

The first-order axiomatization of continuous change in conceptual neighborhoods is an application of a process ontology that supports reasoning about action and change in the RCC by providing a complete classification of all possible activities that arise in dynamic domains based on RCC.

We can extend the approach taken in this paper to specify process ontologies based on mereotopologies that axiomatize notions such as boundaries and holes, e.g. the theory RT_0 by [Asher and Vieu, 1995], and axiomatize continuous transitions in such domains. This would lay the groundwork for rigorous process ontologies in manufacturing domains and geospatial applications.

⁷The Prover9 files for Theorem 3 can be found at <http://colore.oor.net/rcc%5Fcontinuous%5Fprocess/theorems>

References

- [Aameri, 2012] B. Aameri. Using partial automorphisms to design process ontologies. In *Proceedings of the 7th International Conference on Formal Ontology in Information Systems*, pages 309–322. IOS Press, 2012.
- [Allen, 1983] J. F. Allen. Maintaining knowledge about temporal intervals. *Communications of the ACM*, 26(11):832–843, 1983.
- [Asher and Vieu, 1995] N. Asher and L. Vieu. Toward a geometry of common sense: A semantics and a complete axiomatization of mereotopology. In *Proceedings of IJCAI95*, 1995.
- [Bhatt and Loke, 2008] M. Bhatt and S. Loke. Modelling dynamic spatial systems in the situation calculus. *Spatial Cognition and Computation*, 8(1-2):86–130, 2008.
- [Bhatt et al., 2006] M. Bhatt, J. Rahayu, and G. Sterling. Qualitative Spatial Reasoning with Topological Relations in the Situation Calculus. In *Proceedings of the Florida AI Research Society Conference*, pages 713–718, 2006.
- [Bredikhin, 1976] D.A. Bredikhin. Inverse semigroups of local automorphisms of universal algebras. *Siberian Mathematical Journal*, 17(3):386–393, 1976.
- [Cabalar and Santos, 2011] P. Cabalar and P. Santos. Formalising the fisherman’s folly puzzle. *Artificial Intelligence*, 175(1):346–377, 2011.
- [Cui et al., 1992] Z. Cui, A. Cohn, and D. Randell. Qualitative simulation based on a logical formalism of space and time. In *Proceedings of the AAAI-92*, pages 679–684. AAAI Press, 1992.
- [Davis, 2001] E. Davis. Continuous shape transformation and metrics on regions. *Fundam. Inf.*, 46(1-2):31–54, January 2001.
- [Dylla and Moratz, 2004] F. Dylla and R. Moratz. Exploiting qualitative spatial neighborhoods in the situation calculus. In *Proceedings of the Spatial Cognition Conference*, pages 304–322. Springer-Verlag, 2004.
- [Dylla and Wallgrün, 2007] F. Dylla and J. Wallgrün. Qualitative spatial reasoning with conceptual neighborhoods for agent control. *J. Intell. Robotics Syst.*, 48(1):55–78, January 2007.
- [Egenhofer and Al-Taha, 1992] M. Egenhofer and K. Al-Taha. Reasoning about gradual changes of topological relationships. In *Proceedings of Theories and Methods of Spatio-Temporal Reasoning in Geographic Space*, pages 196–219. Springer-Verlag, 1992.
- [Freksa, 1991] C. Freksa. Conceptual neighborhood and its role in temporal and spatial reasoning. In *Proceedings of the International Workshop on Decision Support Systems and Qualitative Reasoning*, pages 181–187, 1991.
- [Freksa, 1992] C. Freksa. Temporal reasoning based on semi-intervals. *Artificial Intelligence*, 54(1-2):199–227, 1992.
- [Galton, 1995] A. Galton. A qualitative approach to continuity. In *Proceedings of the Time, Space and Movement workshop*, pages 23–27, France, 1995.
- [Galton, 2000] A. Galton. *Qualitative spatial change*. Spatial information systems. Oxford University Press, 2000.
- [Ganyushkin and Mazorchuk, 2009] O. Ganyushkin and V. Mazorchuk. *Classical Finite Transformation Semigroups: an Introduction*. Springer, UK, 2009.
- [Grenon and Smith, 2004] P. Grenon and B. Smith. Snap and span: Towards dynamic spatial ontology. *Spatial Cognition and Computation*, 4(1):69–103, 2004.
- [Gruninger et al., 2010] M. Gruninger, T. Hahmann, A. Hashemi, and D. Ong. Ontology Verification with Repositories. In *Proc. of the 6th FOIS Int. Conference*, pages 317–330, Toronto, Canada, 2010. IOS Press.
- [Gruninger, 2003] M. Gruninger. Ontology of the Process Specification Language. In *Handbook on Ontologies in Information Systems*. Springer-Verlag, 2003.
- [Hazarika and Cohn, 2001] S. Hazarika and A. Cohn. Qualitative spatio-temporal continuity. In *Proceedings of the Conference on Spatial Information Theory*, pages 92–107. Springer, 2001.
- [Hazarika, 2005] S.M. Hazarika. *Qualitative Spatial Change: Space Time Histories and Continuity*. PhD thesis, University of Leeds, School of Computing, 2005.
- [Lawson, 1998] M.V. Lawson. *Inverse Semigroups: The Theory of Partial Symmetries*. World Scientific, Singapore, 1998.
- [McCune, 2005 2010] W. McCune. Prover9 and mace4. <http://www.cs.unm.edu/~mccune/prover9/>, 2005–2010.
- [Muller, 1998] P. Muller. A Qualitative Theory of Motion Based on Spatio-Temporal Primitives. In *Proceedings of the Conference on Knowledge Representation and Reasoning*, pages 131–143, 1998.
- [Randell et al., 1992] D. A. Randell, Z. Cui, and A. Cohn. A spatial logic based on regions and connection. In *Proceedings of the Third International Conference Principles of Knowledge Representation and Reasoning*, pages 165–176. San Mateo, California, 1992.
- [Stell, 1999] J. G. Stell. Boolean connection algebras: A new approach to the region-connection calculus. *Artificial Intelligence*, 122:111–136, 1999.
- [Zimmermann and Freksa, 1993] K. Zimmermann and C. Freksa. Enhancing spatial reasoning by the concept of motion. In *Prospects for Artificial Intelligence*, pages 140–147. IOS Press, 1993.
- [Zimmermann, 1993] K. Zimmermann. *Enhancing Qualitative Spatial Reasoning: Combining Orientation and Distance*. Kognitionswissenschaft Hamburg/Bericht. Graduiertenkolleg Kognitionswiss., Univ. Hamburg, 1993.

Qualitative Spatial Representation and Reasoning in Angry Birds: First Results

Peng Zhang and Jochen Renz
Research School of Computer Science
The Australian National University
Canberra, Australia
{u4969566, jochen.renz}@anu.edu.au

Abstract

Angry Birds is a popular video game where the task is to kill pigs protected by a structure composed of different building blocks that observe the laws of physics. The structure can be destroyed by shooting the angry birds at it. The fewer birds we use and the more blocks we destroy, the higher the score. One approach to solve the game is by analyzing the structure and identifying its strength and weaknesses. This can then be used to decide where to hit the structure with the birds.

In this paper we use a qualitative spatial reasoning approach for this task. We develop a novel qualitative spatial calculus for representing and analyzing the structure. Our calculus allows us to express and evaluate structural properties and rules, and to infer for each building block which of these properties and rules are satisfied. We use this to compute a heuristic value for each block that corresponds to how useful it is to hit that block. We evaluate our approach by comparing its performance with the winner of the recent Angry Birds AI competition.

1 Introduction

Qualitative spatial representation and reasoning has numerous applications in Artificial Intelligence including robot planning and navigation, interpreting visual inputs and understanding natural language [Cohn and Renz, 2008]. In recent years, plenty of formalisms for reasoning about space were proposed [Rajagopalan, 1994; Liu, 1998; Renz and Ligozat, 2005]. An emblematic example is the RCC8 algebra proposed by Randell *et al.* [1992]. It represents topological relations between regions such as "x is disconnected from y"; however, it is unable to represent direction information such as "x is on the right of y" [Balbiani *et al.*, 1999]. The Rectangle Algebra (RA) [Mukerjee and Joe, 1990; Balbiani *et al.*, 1999], which is an extension of the Interval Algebra (IA) [Allen, 1983], can express orientation relations and at the same time represent topological relations, but only for rectangles. When we want to reason about multiple aspects of relations between regions, a possible method is to combine several formalisms. For example, when we want to reason about topology and direction relations of regions with

arbitrary shapes, we can combine RCC8 and RA. It has been shown that the problem of deciding consistency of a joint basic network of RCC8 and RA constraints is still in polynomial time [Liu *et al.*, 2009]. However, if we only consider the maximum bounding rectangles (MBR) of regions, RA is expressive enough to represent both direction and topological information.

RA is designed for reasoning about rectangular objects in 2-dimensional space whose sides are parallel to the axes of some orthogonal basis. However, when we consider a 2-D structure of such objects under the influence of gravity, we need to be able to represent information about the stability of the structure. Ideally, we want a representation that allows us to infer whether the structure will remain stable or whether some parts will move under the influence of the gravity or some other forces (e.g. the structure is hit by external objects). Additionally, if the structure is regarded as unstable, we want to be able to infer the consequences of the instability, i.e., what is the impact of movements of the unstable parts of the structure.

The Rectangle Algebra is not expressive enough to reason about the stability or consequences of instability of a structure. For example, in Fig. 1(a) and (b), assume the density of the objects is the same. The RA relation between object 1 and object 2 in these two figures are both (start inverse, meet inverse), but obviously the structure in figure 1(a) is stable whereas object 1 in (b) will fall. In order to make such distinctions, we need to extend the granularity of RA and introduce new relations that enable us to represent these differences. In this paper, we introduce an *extended Interval Algebra* (EIA) which contains 27 relations instead of the original 13. We use the new algebra as a basis for an *extended Rectangle Algebra* (ERA), which is obtained in the same way as the original RA. Depending on the needs of an application, we may not need to extend RA to 27 relations in each dimension. Sometimes we only need the extended relations in one axis. Thus, the extended RA may include 13×27 , 27×13 or 27×27 relations depending on the requirement of different tasks.

We built an agent based on this model to participate the Angry Birds competition¹ which aims to play the Angry Birds game automatically and rationally. The result shows that the agent based on this model is able to interpret low-level infor-

¹<http://ai2012.web.cse.unsw.edu.au/abc.html>

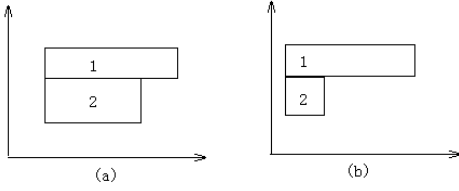

Figure 1: Two configurations with the same RA relation (si,mi)

information from the scene or video input as higher level semantic descriptions [Fernyhough *et al.*, 1999]. Moreover, although qualitative spatial representation and reasoning has been applied to some simple physical systems to do some common sense reasoning [Klenk *et al.*, 2005], there is few work on reasoning on more complicated physical models; thus, this paper is an exploration of this area.

2 Interval Algebra and Rectangle Algebra

Allen's Interval Algebra defines a set \mathcal{B}_{int} of 13 basic relations between two intervals (see Fig. 2). It is an illustrative model for temporal reasoning. Denote the set of all relations of IA as the power set $2^{\mathcal{B}_{int}}$ of the basic relation set \mathcal{B}_{int} . The composition (\circ) between basic relations in IA is illustrated in the transitivity table in Allen [1983]. The composition between relations in IA is defined as $R \circ S = \cup \{A \circ B : A \in R, B \in S\}$.

Relation ^o	Illustration ^o	Interpretation ^o
X b Y ^o Y a X ^o		X takes place before Y ^o
X m Y ^o Y mi X ^o		X meets Y (i stands for <i>inverse</i>) ^o
X o Y ^o Y oj X ^o		X overlaps with Y ^o
X s Y ^o Y si X ^o		X starts Y ^o
X d Y ^o Y di X ^o		X during Y ^o
X f Y ^o Y fi X ^o		X finishes Y ^o
X = Y ^o		X is equal to Y ^o

Figure 2: The 13 basic relations of the Interval Algebra

RA is an extension of IA for reasoning about the 2-dimensional space. The basic objects in RA are rectangles whose sides are parallel to the axes of some orthogonal basis in 2-dimensional Euclidean space. The basic relations of RA can be denoted as $\mathcal{B}_{rec} = \{(A, B) | A, B \in \mathcal{B}_{int}\}$. The relations in RA are defined as the power set of \mathcal{B}_{rec} . The composition between basic RA relations is defined as $(A, B) \circ (C, D) = (A \circ C) \times (B \circ D)$.

3 The Extended Rectangle Algebra (ERA)

In order to express the stability of a structure and reason about the consequences of the instability in a situation which ob-

serves physical rules, we extend the basic relations of IA from 13 relations to 27 relations denoted as \mathcal{B}_{eint} (see Fig. 3).

Relation	Illustration	Interpretation
X b Y Y a X		X takes place before Y
X m Y Y mi X		X meets Y (i stands for <i>inverse</i>)
X mom Y Y momi X		most part of X overlaps with most part of Y
X lol Y Y loli X		less part of X overlaps with less part of Y
X mol Y Y moli X		most part of X overlaps with less part of Y
X lom Y Y lomi X		less part of X overlaps with most part of Y
X ms Y Y msi X		X starts Y and cover most part of Y
X ls Y Y lsi X		X starts Y and cover less part of Y
X ld Y Y ldi X		X during left part of Y
X rd Y Y rdi X		X during right part of Y
X cd Y Y cdi X		X during Y and the midperpendicular of Y through X
X mf Y Y mfi X		X finishes Y and cover most part of Y
X lf Y Y lfi X		X finishes Y and cover less part of Y
X eq Y		X is equal to Y

Figure 3: 27 basic relations \mathcal{B}_{eint} for extended IA

Definition 1 (The extended IA relations). *We introduce the centre point of an interval as a new significant point in addition to the start and end points. For an interval a , denote centre point, start point and end point as c_a , s_a and e_a , respectively.*

1. The 'during' relation has been extended to 'left during', 'centre during' and 'right during' (ld, cd & rd).

- "x ld y" or "y ldi x" : $s_x > s_y, e_x \leq c_y$
- "x cd y" or "y cdi x" : $s_x > s_y, s_x < c_y, e_x > c_y, e_x < e_y$
- "x rd y" or "y rdi x" : $s_x \geq c_y, e_x < e_y$

2. The 'overlap' relation has been extended to 'most overlap most', 'most overlap less', 'less overlap most' and 'less overlap less' (mom, mol, lom & lol).

- "x mom y" or "y momi x" : $s_x < s_y, c_x \geq s_y, e_x \geq c_y, e_x < e_y$

- "x mol y" or "y moli x" : $s_x < s_y, c_x \geq s_y, e_x < c_y$
- "x lom y" or "y lomi x" : $c_x < s_y, e_x \geq c_y, e_x < e_y$
- "x lol y" or "y loli x" : $c_x < s_y, e_x > s_y, e_x < c_y$

3. The 'start' relation has been extended to 'most start' and 'less start' (ms & ls).

- "x ms y" or "y msi x" : $s_x = s_y, e_x \geq c_y$
- "x ls y" or "y lsi x" : $s_x = s_y, e_x > s_y, e_x < c_y$

4. Similarly, the 'finish' relation has been extended to 'most finish' and 'less finish' (mf & lf).

- "x mf y" or "y mfi x" : $s_x > s_y, s_x \leq c_y, e_x = e_y$
- "x lf y" or "y lfi x" : $s_x > c_y, s_x < e_y, e_x = e_y$

Denote the set of relations of extended IA as the power set $2^{\mathcal{B}_{eint}}$ of the basic relation set \mathcal{B}_{eint} . Denote the set of relations of extended RA as the power set $2^{\mathcal{B}_{erec}}$ of the basic relation set \mathcal{B}_{erec} .

Note that EIA can be expressed in terms of INDU relations [Pujari *et al.*, 2000] if we split each interval x into two intervals x_1 and x_2 that meet and have equal duration. However, this would make representation of spatial information very awkward and unintuitive. There is also some similarity with Ligozat's general intervals [Ligozat, 1991] where intervals are divided into zones. However, the zone division does not consider the half point.

4 Application of extended RA in Angry Birds

4.1 Rules based on the extended RA relations for analysing the structure

With these extended RA relations, it is possible to build a set of rules to determine some properties of a structure such as stability of a simple structure or consequences after some external influences act on the structure. Then, integrating all the proposed rules, we are able to do some further inferences to predict the consequences of a shot and calculate a heuristic value. This value will suggest which object is a proper target to hit to maximize the damage. Assume the objects are only rectangles whose sides are parallel to the axes of some orthogonal basis.

Rule 1. Rules for determining stability

We will now specify rules that determine for each target object whether it is stable. Empirically, if we do not consider the impacts of the supportees of an object, there are three situations that an object will remain stable.

Rule 1.1

The target object is just on the ground \Rightarrow object is stable

Rule 1.2

For the target object $x \in O$ (O is the set of all objects in the structure.), $\exists y, z \in O$:

$R_{x,y} \in \{momi, moli, lomi, loli, msi, lsi, ldi\} \times \{mi\}$
and $R_{x,z} \in \{mom, mol, lom, lol, mfi, lfi, rdi\} \times \{mi\}$
 $\Rightarrow x$ is stable

This rule describes the target object with supportees on both left and right sides stable.

Rule 1.3

For the target object x , $\exists y$:

$R_{x,y} \in \{ms, mf, msi, ls, mfi, lf, cd, cdi, ld, rd, mom, momi, lomi, mol\} \times \{mi\}$
 $\Rightarrow x$ is stable

This rule illustrates that if vertical projection of the mass centre of the target fall into the region of its supporter, it is stable.

Rule 1.2 & *1.3* only consider the impacts of the supportees. However, sometimes the supportees may also influence the stability. Thus, we can add more rules to determine more complex situations.

Rule 1.4

For the target object x , $\exists y$:

$R_{x,y} \in \{ld, cd, rd, ms, ls, mf, lf, eq\} \times \{mi\}$
or $\exists y, z$:

$R_{x,y} \in \{momi, moli, lomi, loli, msi, lsi\} \times \{mi\}$
 $R_{x,z} \in \{mom, mol, lom, lol, mfi, lfi\} \times \{mi\}$

$\Rightarrow x$ will remain stable no matter where its supportees are.

In this rule, the target object has at least one supportees on

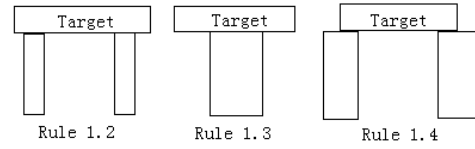

Figure 4: Illustration of Rule 1.2, 1.3 & 1.4

each side, and the edges of the supportees exceed the edges of the target object. Thus, no matter where the supportees are, they will not affect the stability of the target. Fig.4 illustrates *Rule 1.2, 1.3 & 1.4*.

Rule 1.5

$\forall y \in O$:

$R_{x,y} \notin \{ld, cd, rd, momi, moli, lomi, loli, ms, msi, ls, lsi, mf, lf, eq\} \times \{mi\}$

and $R_{x,y} \in \{ldi, cdi\} \times \{mi\}$

and $\exists z : R_{x,z} \in \{mom, mol, lom, lol, mfi, lfi, rdi\} \times \{mi\}$

and $\exists u \in O, R_{x,u} \in \{ldi, moli, lsi\} \times \{m\}$

$\Rightarrow x$ may be unstable.

This rule above can explain the configuration in fig. 5(a) which is that a supportee can make a stable object unstable.

Rule 1.6

$\forall y \in O$:

$R_{x,y} \notin \{ld, ldi, cd, cdi, rd, momi, moli, lomi, loli, ms, msi, ls, lsi, mf, lf, eq\} \times \{mi\}$

and $\exists z : R_{x,z} \in \{mom, mol, lom, lol, mfi, lfi, rdi\} \times \{mi\}$

and $\exists u \in O, R_{x,u} \in \{mom, mol, lol\} \times \{m\}$

and $\exists v \in O, R_{x,v} \in \{ms, mf, msi, ls, mfi, lf, cd, cdi, ld, rd, mom, momi, lomi, mol\} \times \{mi\}$

$\Rightarrow x$ may be stable.

This rule explains that a supportee can force its support to be stable(example see fig. 5(b)).

In the above two rules, "may" is used to express the uncertainty of these situations, because in a qualitative way, we cannot always tell what will exactly happen.

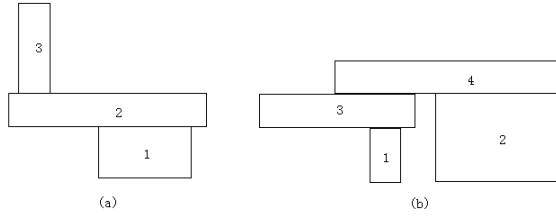

Figure 5: Configurations that need to consider the effects of supportees

Rule 2. Rules for determining reachability of the bird

In Angry Birds, we need to shoot a bird at the structure. When choosing the target, we need to consider which object can be reachable directly for the bird.

The rules for determining the reachability of the bird is shown below:

For a target object $x \in O$, R_x is the set of ERA relations between x and all other objects

$$\forall R_{x,y} \in R_x, y \neq x :$$

$$R_{x,y} \in \{b, ldi, cdi, rdi, mom, mol, lom, lol, moli, momi, m, ms, ls, msi, lsi, mfi, lfi, eq\} \times \{A, A \in R_{eint}\}$$

$$\cup \{a, ld, cd, rd, lomi, loli, mi, mf, lf\} \times \{b, a, m, mi, mom, mol, lom, lol, momi, moli, lomi, loli, ldi, cdi, rdi, msi, lsi, mfi, lfi\}$$

$$\Rightarrow \text{The target } x \text{ is directly reachable for a bird}$$

This rule explains that if there is no other object blocks the path between the bird and the target object, the target is directly reachable by the bird.

Rule 3. Rules for detecting support and sheltering structures

The entire structure in Angry Birds game is often large and even in some levels all the objects in the world are constructed into only one structure. As can be found in most levels, many pigs are set on support structures sometimes with multi-level supportees. Then a good idea to kill the pig (if not directly reachable) is to destroy the support structure and the pig will probably die. Another useful substructure is the sheltering of the pigs. The reason is straightforward, if a pig is not reachable, there must be some objects that protect it; these objects form the sheltering structure of the pigs. Similarly, destroying the sheltering structures can either kill the pig or make the pig directly reachable to the bird.

Specifically, in order to separate the support structure of a pig from the larger structure, it is necessary to include the depth information of the supportees(see fig. 6 the illustration of support structure with depth). This is helpful when only considering the most essential supportees or only several layers of supportees are required. The rules for determining the

direct supporter can be expressed using original RA relations:

Rule 3.1

For objects $x,y \in O$

$$R_{x,y} \in \{d, di, o, oi, s, si, f, fi, eq\} \times \{m\}$$

$$\Rightarrow y \text{ directly supports } x$$

This rule describes that if two objects vertically contact, the nether object supports the other one.

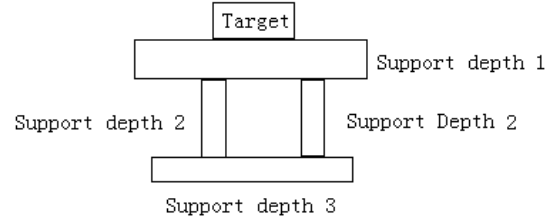

Figure 6: Illustration of support structure

Using the rule above, we can further get the supportees of the supportees, then we can collect all direct or indirect supportees of a certain object.

Similarly, a sheltering structure consists of the closest protection objects of the pig that can avoid the pig from a directly hit from each direction including the hit from backward. Specifically, a sheltering structure of a pig could consist of left, right and roof sheltering objects. In order to get the sheltering structure of a certain object (usually a pig), the first step is to get the closest object from the left side of the queried object; then, get the supportee list of the object (similar process as getting the supporter list); after that, get the right closest object with its supportee list. The next step is to check if the two supportee lists have objects in common, if so, pick the one with smallest depth as the roof object of the sheltering structure; if not, there is no sheltering structure for the queried object. If a roof object is found, also put the supportees of both the left and right closest objects with smaller depth than the roof object into the sheltering structure. Finally, put the supportees of both left and right closest objects which are not below the queried object into the sheltering structure.

The rules expressed in extended RA relations for determining sheltering objects consists of three parts (These set of rules can also be expressed in original RA):

Rule 3.2 The rules for getting potential left and right sheltering objects(take left side as an example)

For an object $x \in O$, denote S_l as the set of potential left sheltering objects of x .

$$\forall y \in O,$$

$$R_{x,y} \in \{b, d, di, o, m, fi\} \times \{d, di, o, oi, s, si, f, fi, eq\}$$

$$\Rightarrow \text{put } y \text{ into } S_l$$

Rule 3.3 The rules for choosing closest sheltering objects

$$\forall y, z \in S_l,$$

$$R_{y,z} \in \{b, d, o, m, s\} \times \{A, A \in R_{eint}\}$$

$$\Rightarrow \text{delete } y \text{ from } S_l, \text{ otherwise delete } z$$

Finally, the closest objects will remain.

4.2 The integration of the rules to evaluate a shot

With the four rules described above, we are able to integrate the rules and further infer the possible consequences after a shot has been made. In order to predict the final consequence of an external influence on the structure, the direct consequence and its following subsequences should be analysed in detail. Funt suggested a similar method to simulate the consequence of a structure with a changed object which assumes that the changed object disappears and chooses the most significant unstable object to simulate the consequence [Funt, 1987]. In this case, a certain type of object can be affected by four configurations.

Configuration 1 The target object in the structure is hit directly by another object. The direct consequence will be in three types which are destroyed, falling and remaining stable. Empirically, the way to determine the consequence of the hit depends on the height and width ratio of the target. For example, if an object hits a target with the height and width ratio larger than a certain number (such as 2), the target will fall down. And this ratio can be changed to determine the conservative degree of the system. In other words, if the ratio is high, the system tend to be conservative because many hits will be determined as no influence on the target. Moreover, if the external object hits a target with the height and width ratio less than one, the target itself will remain stable temporarily because the system should also evaluate its supporter to determine the final status of the target. In some situations, we may also be concerned with the destruction of the target, such as in the Angry Birds game. After deciding the direct consequence of the hit, the system should be able to suggest further consequences of the status change of the direct target. Specifically, if the target is destroyed, only its supportees will be affected. If the target falls down, the configuration will be more complex because it may influence its supporters due to the friction, supportees and neighbours. If the target remains stable temporarily, it will also influence its supporters and its supporters may again affect it from the further simulation.

Configuration 2 The supportee of the target object falls down which is a less complex one. Similar to the process that set the height and width ratio to determine the stability of an object, this target object's stability is also represented by the ratio but the number should be larger (about 5) because the influence from supportee is much weaker than it from direct hit. If the target is considered as unstable, it will fall down and affect its neighbours and supporters; otherwise, it will only influence its supporters (see fig. 7).

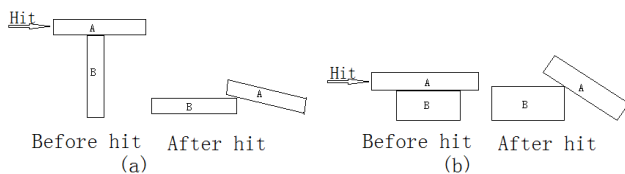

Figure 7: Configuration 2

Configuration 3 The supporter of the target object falls down. Here a simple structure stability check process (applying Rule 1) is necessary because after a supporter falls, the target may have some other supporters and if the projection of its mass centre falls into the areas of the other supporters, it also can stay stable. Then, if the target remains stable, it again will only affect its supporters due to the friction; otherwise, it may fall and affect its supporters, supportees and neighbours (see fig. 8(a)).

Configuration 4 The supporter of the target is destroyed. This is more like a sub configuration of the previous one. If the target can remain stable after its supporter destroyed, it may fall and affect its supporters, supportees and neighbours (see fig. 8(b)).

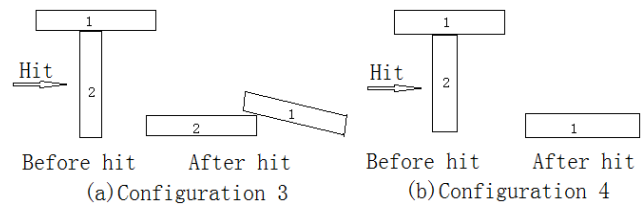

Figure 8: Configuration 3&4

4.3 Calculation of the heuristic value

Then, with all the affected objects in a list, the quality of the shot can be evaluated by calculating a total score of the affected objects. The scoring method is defined as: if an object belongs to the support structure or the sheltering structure of a pig, 1 point will be added to this shot; and if the affected is itself a pig, 10 points will be added to the shot. After assigning scores to shots at the objects, the target with highest score is expected to have the largest influence on the structures containing pigs when it is destroyed. Then, based on different strategies, the agent can choose either to hit the reachable object with highest heuristic value or generate a sequence of shot in order to hit the essential support object of the structure.

Algorithm 1 illustrates the whole process for evaluating a shot at all possible targets.

We first extract the ERA relations between all objects and then match the rules for all relevant combinations of objects. Thus the process of evaluating the significance of the targets is straightforward and fast.

5 Evaluation

We built an agent that uses the rules described in Section re-fApplication of extended RA in Angry Birds to perform a structural analysis of a given Angry Birds scenario and to determine which target to hit next. The organizers of the previous Angry Birds AI competition (<http://ai2012.web.cse.unsw.edu.au/abc.html>) provided a computer vision system that detects the minimum bounding boxes (MBB) of all objects of an Angry Birds screen shot and a classification of each object (pig, bird, wooden block, ice block, etc). We take these boxes as input and evaluate

Algorithm 1 process of evaluating a shot

```

for all Objects  $o$  in the structure do
  init ongoing list 'ol' and affected list 'al'
  add o into al
  applying rule 1 and 3 (integrating in the 4
  configurations) to get affected objects 'ao'
  add all ao into ongoing list
  for all ongoing objects ' $oo$ ' in  $ol$  do
    add oo into al and delete oo from ol
    for all objects  $ao'$  affected by  $oo'$  do
      if  $ao' \notin al$  then
        add ao into ol
      end if
    end for
  if  $ol = \emptyset$  then
    break
  end if
end for
calculate heuristic value of o
get stability of each object
end for
output a list of heuristic values for shots at all
  target objects in descending order with reachability

```

each block according to our rules. For example, in the Angry Birds level shown in fig. 9, part of the output for evaluating the shot (see fig. 10) illustrates that the agent is able to infer that the essential supporter of the structure is object 19, and among the reachable objects, hitting object 6 can result in maximum damage to the structure.



Figure 9: A sample level in Angry Birds

Our rules work well when the given MBBs closely resemble the actual blocks. When blocks are leaning to the left or right, our rules only provide a vague approximation of the real structural situation. Also, our rules treat each block equally, i.e., we do not distinguish between blocks of different materials that might have different mass or density, but purely focus on structural properties. Despite this, our agent performs quite well when comparing it to the winner of the last Angry Birds AI competition. We compared our agent with the winning agent on the publically available Poached Eggs levels (chrome.angrybirds.com). Our agent was able to achieve higher scores on average and to solve more levels than last years winner. Fig. 11 demonstrates the results of some sample levels from our agent

Target ID: 19.0 not reachable	Target ID: 25.0 not reachable
score: 56	score: 46
From Left	From Right
Affected objects:	Affected objects:
15.0 Consequence: Fall affecter: 19.0	15.0 Consequence: Fall affecter: 25.0
111.0 Consequence: Fall affecter: 23.0	111.0 Consequence: Fall affecter: 23.0
...	...
Target ID: 13.0 not reachable	Target ID: 6.0 reachable
score: 46	score: 36
From Left	From Left
Affected objects:	Affected objects:
15.0 Consequence: Fall affecter: 13.0	15.0 Consequence: Fall affecter: 13.0
111.0 Consequence: Fall affecter: 23.0	111.0 Consequence: Fall affecter: 23.0
...	...

Figure 10: Part of the output from for shot evaluation

and the winning agent. These levels shown in the figure are all constructed with complex structures, thus, in these levels, our agent performed much better than the winning agent. We compare our agent with the benchmarks given at www.aibirds.org/benchmarks.html for all participants of the 2012 competition. Our agent obtained a total score of 954960 over the first 21 poached eggs levels, which is higher than any other agent.

Agent Name	Agent Based on ERA	Winning Agent
Level	Score	Score
16	64060	39090
17	47960	40060
18	49870	27950
19	31130	15872
20	42410	57010

Figure 11: Results comparison

6 Discussion

In this paper we have introduced an extended rectangle algebra useful for representing and reasoning about stability and other properties of 2-dimensional structures. By splitting some basic interval relations into more detailed ones, we obtained 27 interval relations in each dimension that can express the physical relations between rectangular objects more precisely. We used the new algebra for defining some useful structural rules regarding properties such as stability, reachability, support, and shelter. We tested the usefulness of our rules by designing an agent that performs a structural analysis of Angry Birds levels. Based on these rules, we predict for each block the consequences if it gets hit and calculate a heuristic value that determines the usefulness to hit the block. We then shoot at the block with the highest value that is reachable with the current bird. A comparison with the winner of the last Angry Birds AI competition shows that our structural analysis can lead to a successful strategy for solving Angry Birds. It demonstrates the usefulness of qualitative spatial representation and reasoning approaches for solving real physical problems.

However the rules for reasoning about the consequences of a shot are still preliminary. The mechanical constraints for the motion of the objects, especially for the transfer of the motion between objects, need to be refined. Nielsen's approach [Nielsen, 1988] to analyse possible motions is suitable for our case. For example we could also consider translational motion and rotate motion instead of the simple 'fall'. Also, objects that are not equivalent to their MBRs, that is objects that can lean to the left or right may need to be differently treated. We will also consider different materials of objects in the next stage.

References

- [Allen, 1983] J. F. Allen. Maintaining knowledge about temporal intervals. *Communications of the ACM*, 26:832–843, 1983.
- [Balbiani *et al.*, 1999] P. Balbiani, J.F. Condotta, and L. Farinas del Cerro. A new tractable subclass of the rectangle algebra. In *IJCAI-1999*, pages 442–447, 1999.
- [Cohn and Renz, 2008] A. G. Cohn and J. Renz. Qualitative spatial representation and reasoning. In *Handbook of Knowledge Representation*, pages 551–584, Oxford, England, 2008. Elsevier.
- [Fernyhough *et al.*, 1999] J. Fernyhough, A. G. Cohn, and D. C. Hogg. Constructing qualitative event models automatically from video input. *Image and Vision Computing*, 18:81–103, 1999.
- [Funt, 1987] Brian V. Funt. Problem-solving with diagrammatic representations. In *Readings in computer vision: issues, problems, principles, and paradigms*, pages 456–470. Morgan Kaufmann, 1987.
- [Klenk *et al.*, 2005] M. Klenk, K. Forbus, E. Tomai, H. Kim, and B. Kyckelhahn. Solving everyday physical reasoning problems by analogy using sketches. In *AAAI-2005 Proceedings*, pages 209–215, 2005.
- [Ligozat, 1991] G. Ligozat. Gerard ligozat: On generalized interval calculi. In *AAAI-1991*, pages 234–240, 1991.
- [Liu *et al.*, 2009] W. Liu, S. Li, and J. Renz. Combining rcc-8 with qualitative direction calculi: Algorithms and complexity. In *IJCAI-2009*, pages 854–859, 2009.
- [Liu, 1998] J. Liu. A method of spatial reasoning based on qualitative trigonometry. *Artificial Intelligence*, 98:137–168, 1998.
- [Mukerjee and Joe, 1990] A. Mukerjee and G. Joe. A qualitative model for space. In *AAAI-1990 Proceedings*, pages 721–727. AAAI Press and MIT Press, 1990.
- [Nielsen, 1988] Paul Nielsen. A qualitative approach to mechanical constraint. In *AAAI-1988 Proceedings*, pages 270–274, 1988.
- [Pujari *et al.*, 2000] Arun K. Pujari, G Vijaya Kumari, and Abdul Sattar. Indu: An interval duration network. In *In Proceedings of Sixteenth Australian joint conference on AI*, pages 291–303. SpringerVerlag, 2000.
- [Rajagopalan, 1994] R. Rajagopalan. A model for integrated qualitative spatial and dynamic reasoning about physical systems. In *Proceedings of the 12th National Conference on Artificial Intelligence (AAAI-94)*, pages 1411–1417, 1994.
- [Randell *et al.*, 1992] Randell, Z. Cui, and T. Cohn. An interval logic for space based on connection. In *Proceedings of the 10th European Conference on Artificial Intelligence*, pages 394–398. Wiley, 1992.
- [Renz and Ligozat, 2005] J. Renz and G. Ligozat. Weak composition for qualitative spatial and temporal reasoning. In *Principles and Practice of Constraint Programming CP 2005, 11th International Conference*, pages 534–548, 2005.

Understanding Human Spatial Conceptualizations to Improve Applications of Qualitative Spatial Calculi

Jan Oliver Wallgrün, Frank Dylla, Alexander Klippel, Jinlong Yang

Department of Geography, GeoVISTA Center, The Pennsylvania State University

{wallgrun,klippel,inlong}@psu.edu

Cognitive Systems, Spatial Cognition SFB/TR 8, Universität Bremen

dylla@sfbtr8.uni-bremen.de

Abstract

Qualitative calculi have been employed to model human commonsense knowledge and reasoning about spatial and temporal. However, for many calculi the suitability to capture human conceptualizations has not been demonstrated. We propose a taxonomy of fundamental qualitative reasoning problems, identify typical tasks to which qualitative calculi are applied, and discuss how the reasoning problems occur as subproblems in the identified tasks. Against this backdrop, we argue that there exists a need to conduct behavioral studies on human categorization and similarity assessment to evaluate, refine, and improve the performance of calculi in the discussed tasks. We present a research framework designed to investigate human spatial and temporal conceptualizations and their relationship to qualitative calculi and reflect on insights gained and challenges encountered.

1 Introduction

Qualitative spatial and temporal reasoning (QSTR) techniques have been employed to model and process knowledge about space and time in various domains including Geographic Information Systems (GIS) [Egenhofer, 1997], spatial design [Bhatt *et al.*, 2011], and robotics [Westphal *et al.*, 2011]. Very prominent in QSTR is the notion of a *qualitative calculus*, which defines a finite set of basic relations for a particular spatial (or temporal) aspect such as topology (contained, disjoint, etc.) or direction (north, left, etc.). Qualitative calculi have been suggested and deemed suitable to formalize human commonsense conceptualizations and inference [Cohn and Hazarika, 2001; Renz and Nebel, 2007] as well as to interpret natural spatial language [Hois and Kutz, 2008]. However, qualitative calculi have most often been designed with a focus on their theoretical and computational properties, while their suitability to capture how humans represent perceived scenes as well as survey knowledge, use relations to infer new information, assess similarity of spatial arrangements, and externalize spatial knowledge verbally or graphically has not been extensively demonstrated.

While recently experimental work on evaluating qualitative calculi in behavioral studies (for overviews see [Mark, 1999;

Klippel *et al.*, 2013]) has started to catch up with the developments in calculus design, there remain many open questions and challenges in understanding human conceptualizations of spatial relations, spatial arrangements and events, and the impacts of different domain semantics and contexts. The goal of behavioral evaluation is to confirm, reject, or refine qualitative calculi and improve their performance from a cognitive as well as computational perspective in different application areas. Important questions in this regard are: What are intuitive levels of granularity for different spatial aspects (e.g., topology, direction, distance) and how do humans assess the similarity of individual relations or spatial arrangements.

The main aim of this paper is to make headway and spur further discussion on the question where experimental studies are needed to improve application of QSTR in practice and what the expected benefits are with respect to different spatial and temporal data processing tasks. To this end, we propose a taxonomy of fundamental qualitative spatial reasoning problems, identify typical high-level tasks to which QSTR approaches have been employed, and discuss the relationship between fundamental reasoning problems and tasks, namely how the different reasoning problems occur as subproblems in the different tasks (Section 2). Against the backdrop of this analysis, we provide arguments from both a cognitive and computational perspective why there exists a need for future behavioral studies on human conceptualizations, categorization, and similarity assessment to support the discussed tasks (Section 3). In Section 4, we briefly describe the research framework that we have established to conduct behavioral experiments efficiently based on category construction experiments and a crowdsourcing approach employing Amazon's Mechanical Turk. Finally, we report on insights and challenges encountered while conducting experimental studies in this framework (Section 5).

2 Fundamental QSTR problems and tasks

In qualitative calculi, the set of basic relations is typically defined such that for any pair of objects exactly one relation holds, meaning the basic relations are jointly exhaustive and pairwise disjoint (JEPD). Here, as an example, we employ the 9-intersection calculus for topological relations [Egenhofer and Franzosa, 1991] discriminating eight basic relations for two spatially extended entities: *disjoint*, *meet*, *overlap*, *contain*, *inside*, *cover*, *coveredBy*, *equal*. Reasoning is performed

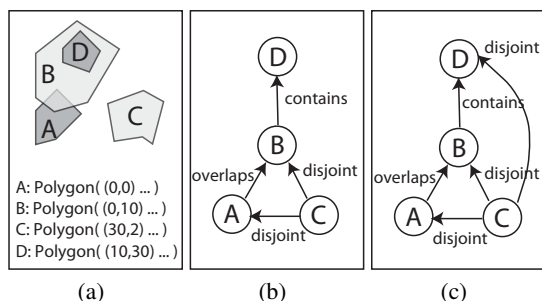

Figure 1: (a) A geometric and (b) a qualitative description of a spatial scene. (c) Result of applying algebraic closure.

on the power set of these relations interpreted as disjunctions of the basic relations. For example, the relation $A \{disjoint, meet\} B$ describes that region A is either *disjoint* from or *meets* region B (*meet* means only their boundaries are connected). The *universal relation* (U) consisting of all base relations denotes that nothing is known about the relation of two objects.

In the following, we denote a geometric scene description, that is, a set of object identifiers with associated geometries (e.g., points, lines, polygons) in an arbitrary coordinate system (see Figure 1(a)), as G . Q , on the other hand, stands for a qualitative spatial description, that is, a set of objects and their spatial relationships in terms of relations from a particular calculus. Q is often considered as a directed labeled graph called *qualitative constraint network* (QCN). The nodes (V) represent objects of the domain and the edges (E) are labeled with the relations (see Figure 1(b)). We call a qualitative description that contains only base relations a *scenario*. A *solution* of a QCN refers to an assignment of concrete objects from the involved spatial domain to each object identifier that satisfies all the relations in the QCN.

2.1 Fundamental reasoning problems

We now describe our classification of fundamental QSTR problems. While not exhaustive, it captures the main reasoning tasks that reoccur in different application domains. Problems are described by specifying the input and output signature of the problem (G , Q , etc.) and providing a short explanation without details on algorithms and complexity.

(1) Qualitative abstraction ($G \rightarrow Q$)

Qualitative abstraction describes the translation of a geometric scene description G into a qualitative one Q wrt. a given calculus. For instance, Figure 1(b) could be the result (Q) of translating the scene (G) in Figure 1(a).

(2) Consistency checking ($Q \rightarrow \{true, false\}$)

Consistency checking, also termed the *satisfiability problem*, is the classical QSTR problem [Renz and Nebel, 2007]. Given a QCN as input, the question is whether the network has a solution. One method to check consistency is the algebraic-closure algorithm, potentially in combination with a backtracking search [Renz and Nebel, 2007].

(3) Similarity assessment ($Q \times Q \rightarrow \mathbb{N}_0^+$)

For several tasks, it is essential to evaluate the similarity (or distance) of QCNs. The challenges in similarity assessment

are typically not computational but rather lie in the design of suitable similarity models. A commonly used model is *conceptual neighborhood* which describes how the spatial relationship between two objects in terms of relations from a calculus can continuously change over time [Freksa, 1991]. This idea has been generalized to configurations of more than two objects [Ragni and Wöfl, 2005].

(4) Equivalence transformation problems ($Q \rightarrow Q$)

Equivalence transformation problems take a QCN as input and turn it into an equivalent one, meaning that it has the same set of solutions, but one that additionally satisfies other criteria. We distinguish two main subproblems of this class:

- **Deduction / Minimal network.** Given a QCN one wants to infer as much information as possible from the given relations, e.g. by means of algebraic-closure (cf. (2)). The resulting network then is a refinement of the original network in which some or all base relations have been removed from disjunction that cannot lead to a solution. In the latter case, the resulting QCN is called the *minimal network*. Figure 1(c) depicts a single-step refinement for the universal relation between C and D in Figure 1(b) based on the so-called *composition* operation: $C \text{ disjoint } B \text{ and } B \text{ contains } D \Rightarrow C \text{ disjoint } D$.
- **Most compact network.** Here, the goal is to find an equivalent network that is as simple or compact as possible wrt. a given measure, e.g. number of base relations or relations different from U , e.g. [Wallgrün, 2012].

(5) Integration ($Q^n \rightarrow Q$)

Given n spatial descriptions, the task is to merge the information into a single description. The resulting QCN is supposed to reflect the belief about the state of the world given the information from the input networks, which potentially may lead to conflicts that need to be resolved, e.g. by means of similarity assessment. What is considered an adequate merging depends on the concrete integration task. One can distinguish two main classes *revision* and *update*. In case of revision, additional information about a particular state of the world becomes available and needs to be combined with what was known before. In case of update, one assumes that the state may have changed and that the new information is more up-to-date than the previous knowledge. These different information fusion settings have led to the formulation of different merging operators which in turn have been adopted in work on merging QCNs, e.g. [Dylla and Wallgrün, 2007].

(6) Temporal interpolation ($Q \times Q \rightarrow Q^n$)

Consistent scenarios with a particular number of objects can be thought of as arranged in a complex neighborhood graph in which scenarios are connected if they can change into each other without any other configuration holding in between (see Figure 2), e.g. for *simulation* of how things may develop over time. As discussed in the literature (see, for instance, [Galton, 2000]), the concrete neighborhood structure varies depending on which kind of transformation of the objects are possible.

Typically one is interested in finding the *shortest* connecting path between a source scenario to a goal scenario, e.g., in terms of the number of scenarios traversed. Examples of such

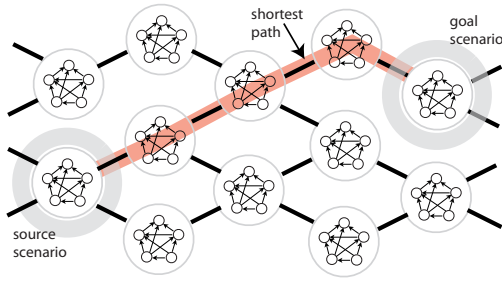

Figure 2: Neighborhood transition and interpolation in a conceptual neighborhood graph. Nodes represent scenarios.

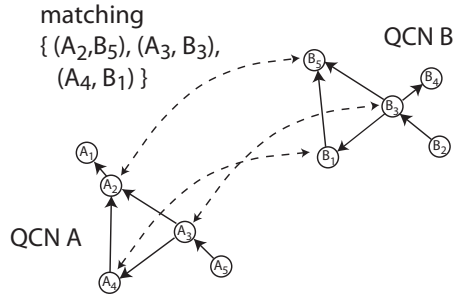

Figure 3: Illustration of the qualitative matching problem.

tasks are *planning* (how to get from one qualitative configuration to another?) and *explanation* (what could have happened given two configurations for two different points in time?).

(7) Matching problems ($Q \times Q \rightarrow R^n$ with $R \subseteq V \times V$)

The matching problem (related to *labeled graph isomorphism*) is to find corresponding relational structures in two given input QCNs Q_1 and Q_2 (see Figure 3). The result consists of one or more matchings each given in form of an associative relation between the node sets of Q_1 and Q_2 . In practice, the identification of *common subgraphs* is required as very often the networks do not contain the exact same set of objects. We distinguish two subclasses depending on whether the relations have to match exactly or not.

- **Exact matching.** Here, relations of corresponding arcs have to be the same or at least compatible, i.e. have a non-empty intersection. In the latter case, consistency needs to be checked for the refined sub-QCN.
- **Inexact matching.** As relations do not have to match exactly, a similarity measure and a cost function are required to trade off the number of matched objects against the similarity of the spatial relations. In addition, the cost function allows for ranking potential matchings.

(8) Realization problems ($Q \rightarrow G$ or $Q \times G \rightarrow G$)

Given a qualitative description Q the goal of realization is a geometric one, that satisfies all relations in Q . We can subdivide further into *generation* of solutions from scratch, e.g. prototypical illustrations, or the *adjustment* of geometric data such that it is compliant with the relations in Q and the changes made are minimal wrt. a given cost function (see, for instance, [Wallgrün, 2012]).

2.2 High-level tasks

The goal of this section is not to provide a detailed or even exhaustive overview of applications of qualitative calculi and QSTR methods. It rather has the purpose of illustrating the main high-level tasks occurring in several application domains and how they can be realized by combining the different computational operations presented in the previous section. Overall we distinguish five main tasks.

Interpreting / understanding human spatial descriptions

One of the main roles of qualitative calculi is to serve in the interpretation and understanding of human externalizations of spatial knowledge. In doing so, the human description, be it textual or graphical, needs to be translated into a formal description that can be further processed in a computer system. The input can, for instance, be a direct utterance from a human, text extracted from a web page, or sketched information.

- **Spatial language.** Understanding a given verbal or textual description of spatial information is a challenging problem. The goal is to derive a formal definition of the meaning in terms of what the objects in the text refer to and what is said about their spatial arrangement. An important subtask thereby is the mapping of spatial prepositions to relations from different qualitative calculi [Hois and Kutz, 2008].
- **Spatial aspects in graphical representations.** Given a graphical representation of spatial knowledge, similar challenges arise as in the case of spatial language: We may be interested in what real world entities correspond to the depicted entities and in extracting the spatial relations holding between them as a first step to understand the deeper meaning of what is shown. Since graphical representations such as sketches are typically incomplete and distorted images of reality, a crucial question is which relations do matter and are most likely to be preserved, and which relations can or should be ignored.

While qualitative abstraction is an important subproblem of interpreting human externalizations of spatial knowledge, in particular for graphical representations, deductive reasoning, consistency checking, and matching can play key roles in determining the most likely interpretation. This can be illustrated using the problem of toponym resolution. Given the natural language description "We left Hartford heading south, crossed the state border and arrived in Springfield", the question is what geographic entities do the ambiguous names Hartford and Springfield correspond to. Assuming a database with geographic background knowledge, deductive reasoning allows for inferring possible candidates.

Maintaining relational knowledge

Storing spatial information in an information system in terms of qualitative relations between objects allows for making use of information extracted from human sources which is qualitative in nature as well as for dealing with underspecified knowledge which is difficult to capture on a geometric level. The idea of a hybrid GIS which allows for storing geometric information as well as qualitative relational information has,

for instance, been explored to facilitate applications of volunteered geographic information (VGI). Information in knowledge bases such as the geospatial semantic web also often comes in relational form. Assuming that the input is already given in qualitative form (otherwise see previous section), involved subproblems are the deduction of new information from new relations, matching to identify correspondences to objects already in the database, and the integration with already contained information including the detection of inconsistencies and their resolution. Finally, storage space becomes an important aspect as storing a relation between each pair of objects is often infeasible. This leads to instances of the most compact network problem for describing the knowledge with as few relations as possible.

Retrieval

One of the main purposes of interpreting human descriptions of spatial knowledge is the provision of more natural, intuitive and intelligent interfaces that allow retrieving information from spatial information systems. One example is the idea of query-by-sketch [Egenhofer, 1997] where a sketch map showing a spatial arrangement of entities is interpreted in terms of spatial relations and used to retrieve matching instances from a spatial database. Another example is the retrieval of spatial knowledge from the web given a natural language expression. The interpretation of human spatial descriptions as discussed above is clearly part of this problem. In addition, information on the other side (e.g. the spatial database or the web) may need to be transferred to a qualitative description as well and then a matching problem between the two qualitative representations needs to be solved. To facilitate similarity based querying and ranked results, inexact matching with similarity assessment is required.

Planning and explanation

Planning and explanation in real world domains need a model about how the world may evolve and QSTR techniques have been successfully demonstrated to provide such models e.g., by pruning the search space of geometric planners in robot arm manipulation tasks and sea navigation. Temporal interpolation leading to continuous sequences of scenarios is key in these applications and consistency checking and similarity assessment are often involved in driving such a sequence.

Generating spatial descriptions

The final task we discuss here is the generation of spatial descriptions that should provide spatial information in an unambiguous but still easily understandable manner. The prototype example of this task is the generation of natural language descriptions of small or large-scale spatial information. Examples are the generation of scene descriptions for blind persons or of route instructions. This task involves the qualitative abstraction of geometrically given knowledge. In addition, equivalence transformation approaches can help in tackling the problem of determining the easiest to understand descriptions. In particular, the notion of the most compact equivalent network can be seen as a means to achieve this. Assuming that spatial information is stored qualitatively, the goal can also be to illustrate the qualitative knowledge graphically by generating an exemplary illustration (see section on

realization). This task for instance arises in spatial assistance systems that aim at suggesting potential solutions to spatial design problems based on certain design rules and may also involve the adjustment of an initial geometric design.

3 A need for experimental evaluation

Our discussion of fundamental reasoning problems and typical tasks in applications made several references to human conceptualizations of spatial relations, spatial language, and human assessment of spatial similarity. The reason for this close connection is that both human and qualitative reasoning are based on a central aspect of (artificial and natural) cognition: categorization. The essence of qualitative reasoning is the identification of equivalence classes that could be referred to as spatial and temporal categories, which, in turn is crucial for humans to make sense of their spatial and temporal environments. It seems to be natural to relate both worlds by evaluating qualitative calculi through behavioral experiments and use results of behavioral experiments as a basis for qualitative calculi. We briefly discuss this connection from two perspectives: human-computer-interaction and computational efficiency.

In order to interpret and process human spatial descriptions as well as to generate descriptions that are natural and take into account cognitive abilities and limitations of humans, we need to understand how humans conceptualize spatial relations and the level of granularity typically applied in human conceptualizations and communication. Moreover, it is important to develop theories on how conceptualization of spatial relations and level of granularity are affected by different context, such as the properties and arrangement of the objects involved in a spatial scene, the semantics of the objects as well as the overall scenario, the task and other properties of the user, or cultural influences. Experimental studies with the goal of determining the semantics of spatial relations and analyzing human spatial conceptualizations and representations can yield the required insights and often allow for a direct comparison of behavioral data and design decision and predictions made by a qualitative calculus.

Another key issue that needs to be addressed via experimental investigations, in particular to facilitate tasks involving retrieval and matching, is how humans assess similarity of individual relations, spatial scenes with several objects, or spatio-temporal events and processes. Suitable similarity models are required in all tasks that involve matching of a spatial description extracted from a human externalization of spatial knowledge to another spatial knowledge base. Similarity assessment is also intimately related to spatial change and the notion of conceptual neighborhood. One would expect that similarity reflects how spatial relations or spatial scenes can develop over time, meaning relations or configurations that are conceptual neighbors in a qualitative formalism are deemed as very similar. Testing this hypothesis as well as developing finer grained models of similarity and conceptualization of spatial change have the potential to improve the performance of qualitative calculi matching as well as temporal recognition and interpolation tasks.

The identification of the correct level of granularity with

respect to human conceptualizations is also important from a computational perspective: An unnecessarily high number of distinguished basic relations can lead to a significant increase of computational costs that could have been avoided. The number of base relations strongly affects the computational costs (in terms of both space and time) of several, if not most, fundamental QSTR problems we identified as we will briefly and exemplarily discuss in the following.

The most direct effect of the number of base relations n of a calculus is with respect to the size of composition table, a look-up table to realize the composition operation in several central QSTR algorithms, in particular the fundamental algebraic closure algorithm. In order to make composition-based reasoning as efficient as possible, QSTR tools such as SparQ [Wallgrün *et al.*, 2007] try to maintain the entire table of the set of general relations (all disjunctions of basic relations) in memory. This table essentially has a size of $(2^n) \times (2^n)$. Hence, it quickly becomes impossible to keep this entire table in memory. In this case, tools tend to restrict themselves to a $n \times n$ table over only the basic relations and each composition needs to be broken down by considering all combinations of basic relations in the involved disjunctions, which also increases with higher n .

Another final important consequence of a higher number of base relations n that should be mentioned here is the number of scenarios for a given number k of objects, which is $n^{(k(k-1)/2)}$. Not all of these scenarios are consistent but overall a higher number of base relations negatively affects the number of conceptual neighbors and as a result the search space for all temporal interpolation problems.

4 Crowdsourcing-based research framework

Category construction tasks [Medin *et al.*, 1987] have been advocated as a means to reveal conceptual structures underlying human understanding of space and time. Based on this approach, we have developed a comprehensive research framework, illustrated in Figure 4, that allows for studying human spatial conceptualizations and similarity assessment and compare it to the qualitative equivalence classes (QECs) stemming from the basic relations distinguished in a particular qualitative spatial calculus. The core tools employed in our approach are our self-developed freely available experimental software CatScan and a tool that allows for instantly performing a large set of analyses with the collected behavioral data. In order to be able to collect experimental data quickly, we have recently adapted our software and shifted to a crowdsourcing approach based on Amazon’s Mechanical Turk. In the following, we provide a brief overview on the steps and components involved in our research framework.

Each circle in our framework starts with a particular spatial calculus and the QECs defined by its basic relations. To investigate the distinctions and similarity assessment made by humans with respect to the spatial aspect addressed by the calculus, visual stimuli need to be created resulting in a set of icons or animations. For each QEC, the same number of randomized variations is created. Moreover, suitable instructions need to be designed that explain what the icons depict and what participants are supposed to do. In several of our ex-

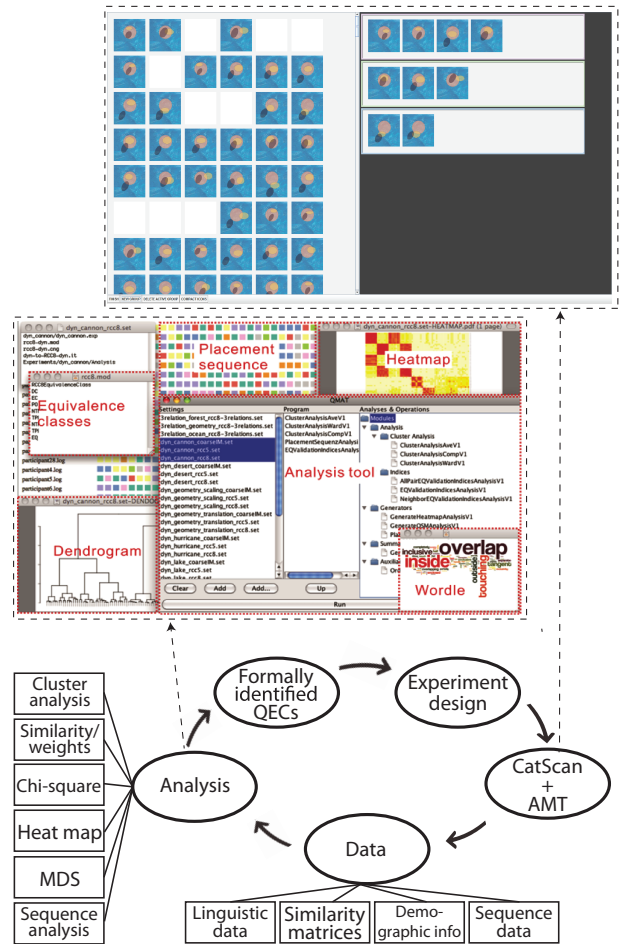

Figure 4: Research framework (after [Klippel *et al.*, 2012b]).

periments we generated different icon sets with the same geometric configurations of objects but different object semantics. For an example, see Figure 4 (top right) which shows icons for qualitatively different configurations of three objects depicting fish habitats on top of an ocean background.

Once the stimulus material is prepared, we run the grouping experiment in CatScan, which allows for the presentation of static and dynamic stimuli. Figure 4 (top right) illustrates the interface during the category construction phase of the experiment. Initially all icons are presented in random order on the left side. Participants create their own categories on the right and then drag icons from the left side into a group on the right side. After the category construction phase, participants have to label and explain the categories they created.

In the past, we typically ran experiments in the lab with several participants performing the experiment simultaneously. However, as mentioned, we recently adapted CatScan such that it can be downloaded and run locally by participants on their own computer such that we can use the crowdsourcing platform Amazon Mechanical Turk (AMT) to run experiments and collect data in an extremely short time (typically a few hours). AMT allows for outsourcing simple tasks referred to as Human Intelligence Tasks (HITs) to a large network of AMT workers all over the world. A quality control

is in place in that the workers only receive reimbursement in case they perform a task successfully and restrictions can be placed allowing only workers above a certain HIT approval rate. Several studies indicate that results are comparable to regular laboratory experiments (e.g., [Paolacci *et al.*, 2010]) but our experience from several experiments shows that it is crucial to design and set up instructions, experiment, payment and bonus incentives carefully to achieve this.

Among others, CatScan collects the following data during an experiment and stores it anonymously: (a) the background and demographic data of the participants, (b) data on the category construction behavior in form of a similarity matrix that stores for each pair of icons whether they were put in the same group, (c) the linguistic labels and explanations for the created groups, and (d) a detailed log file of each of all actions performed by the participants with time stamps. Since starting with the grouping experiments, we have continuously extended and enhanced the methods for analyzing the collected data and comparing the category construction behavior to the QECs defined by a qualitative calculus. Our analysis tool (see Figure 4 top left), essentially a Java interface to R providing several standard and self-developed analysis methods, allows for performing a large number of analyses with a single button click including basic statistics (e.g., regarding number of groups created and time taken), overall similarity matrices that summarize the grouping of all participants and heat maps to visualize them, cluster analyses and dendrograms based on different clustering methods, and cluster validation indices for comparing the category construction behavior of the participants with the QECs of a calculus or the conceptual neighborhood structures. The results of the different analyses, for instance, can be employed for comparing calculi, investigating which calculus provides the most adequate level of granularity, derive similarity measures that can be used to introduce weights into conceptual neighborhood graphs, or suggest modifications leading to a new calculus.

5 Insights & challenges

Historically, the experimental investigations of qualitative calculi have focused on static topological relations (see [Mark, 1999] for an overview). We have extended behavioral evaluations of qualitative calculi in several directions with the goal to fill the need of missing cognitive evaluations and to offer a systematic framework for fundamental spatio-temporal concepts that humans use to understand their dynamic environments. Most prominently, these evaluations have focused on: directions, dynamically changing spatial relations, complex spatial relations, levels of granularity, differences between linguistic and non-linguistic conceptualizations of spatial relations, and cross-linguistic/cultural differences in how fundamental spatial concepts are conceptualized. We also have advanced approaches to transform behavioral data into weighting schemes (similarity values) essential for conceptual neighborhood graphs, an important step to improve spatio-temporal query engines.

Two highlights can be exemplarily summarized as follows:

- The granularity of spatial relations, that is, the number of equivalence classes/categories, identified by qualita-

tive calculi is finer than corresponding human conceptualizations. This aspect was prominently pointed out by Clementini and collaborators [Clementini *et al.*, 1993] and has surfaced through all our experiments (for an overview see [Klippel *et al.*, 2013]). Examples are a dominance of RCC-5 and the 5-relation version of Egenhofer’s intersection models that showed cognitive adequacy in experiments on geographic event conceptualization [Klippel *et al.*, 2013] as well as the conceptualization of complex relations [Wallgrün *et al.*, 2012], a reduction from 26 to 3 prominent relations in case of the DLine-Region calculus [Klippel *et al.*, 2012a], likewise, and a reduction from over 20 relations in Galton’s modes of overlap calculus to essentially 3 prominent relations [Wallgrün *et al.*, to appear]. In the latter case even the explicit instruction to single out as many meaningful relations as possible did not yield different results.

- Semantic context changes the prominence of spatial relations. This has been discussed, for instance, in Coventry and Garrod’s *extra-geometric functional framework* [Coventry and Garrod, 2004] or as *semantic context effects*, especially in the context of color categorization [Kubat *et al.*, 2009]. While topology is considered one of the most abstract and hence universal approaches to characterize spatial relations, we were able to show that even in this case semantic context changes the salience of individual topological relations [Klippel *et al.*, 2013].

Remaining challenges from a cognitive-behavioral perspective can be summarized as follows:

- A large number of calculi has not been evaluated despite their often suggested usefulness in human-machine-interaction contexts. It is necessary to focus on essential calculi as it is not feasible to evaluate every single calculus. While it would make sense to focus on fundamental spatio-temporal concepts, the literature does not offer consensus on what these fundamental concepts are.
- Complex spatial relations, that is scenarios with more than two objects, have only been addressed sporadically [Wallgrün *et al.*, 2012]. It is an open question to which extend primitive relations can easily be used to understand complex relations.
- While we have transformed behavioral data into weighting schemes for conceptual neighborhood graphs, we are far off offering a consistent theory on how similarities between spatio-temporal relations change in dependence of various (semantic) context.
- (Mere)Topology is still the most commonly evaluated qualitative calculus and an expansion to other spatial aspects seems urgently needed.

6 Conclusions and future work

We proposed a classification of fundamental QSTR problems, identified high-level tasks of qualitative spatial calculi, and used these to argue that behavioral evaluation of calculi is urgently needed. Our research framework based on category construction experiments and a crowdsourcing approach provides the means and tools (all freely available) to conduct

these studies. However, many challenges remain, in particular pertaining to spatial (and temporal) aspect other than topology, going from individual relations to spatial scenes and events, and the influence of context and domain semantics. It is our hope that the introduced classification schemes will help to guide future research on the development of qualitative calculi and their cognitive investigation and evaluation.

References

- [Bhatt *et al.*, 2011] Mehul Bhatt, Jae Hee Lee, and Carl Schultz. Clp(qs): A declarative spatial reasoning framework. In Max J. Egenhofer, Nicholas A. Giudice, Reinhard Moratz, and Michael F. Worboys, editors, *COSIT*, volume 6899, pages 210–230. Springer, 2011.
- [Clementini *et al.*, 1993] Eliseo Clementini, Paolino Di Felice, and Peter van Oosterom. A small set of formal topological relationships suitable for end-user interaction. In David J. Abel and Beng Chin Ooi, editors, *SSD*, volume 692, pages 277–295. Springer, 1993.
- [Cohn and Hazarika, 2001] A. G. Cohn and S. M. Hazarika. Qualitative spatial representation and reasoning: An overview. *Fundamenta Informaticae*, 46(1-2):1–29, 2001.
- [Coventry and Garrod, 2004] K. R. Coventry and S.C. Garrod. *Saying, Seeing, and Acting: The Psychological Semantics of Spatial Prepositions*. Psychology Press, 2004.
- [Dylla and Wallgrün, 2007] Frank Dylla and Jan Oliver Wallgrün. Qualitative spatial reasoning with conceptual neighborhoods for agent control. *Journal of Intelligent and Robotic Systems*, 48(1):55–78, 2007.
- [Egenhofer and Franzosa, 1991] Max J. Egenhofer and R. D. Franzosa. Point-set topological spatial relations. *International Journal of Geographical Information Systems*, 5(2):161–174, 1991.
- [Egenhofer, 1997] Max J. Egenhofer. Query processing in spatial-query-by-sketch. *Journal of Visual Languages and Computing*, 8(4):403–424, 1997.
- [Freksa, 1991] Christian Freksa. Conceptual neighborhood and its role in temporal and spatial reasoning. In M. Singh and L. Travé-Massuyès, editors, *Decision Support Systems and Qualitative Reasoning*, pages 181 – 187. 1991.
- [Galton, 2000] Antony Galton. *Qualitative spatial change*. Spatial information systems. Oxford Univ. Press, 2000.
- [Hois and Kutz, 2008] Joana Hois and Oliver Kutz. Natural language meets spatial calculi. In C. Freksa, N. S. Newcombe, P. Gärdenfors, and S. Wölfl, editors, *Spatial Cognition*, volume 5248, pages 266–282. Springer, 2008.
- [Klippel *et al.*, 2012a] A. Klippel, J. Yang, R. Li, and J. O. Wallgrün. Evaluating the cognitive adequacy of the dline-region calculus. In S. Timpf and P. Laube, editors, *Advances in Spatial Data Handling*, pages 91–106, 2012.
- [Klippel *et al.*, 2012b] Alexander Klippel, Jan Oliver Wallgrün, Jinlong Yang, Rui Li, and Frank Dylla. Formally grounding spatio-temporal thinking. *Cognitive Processing*, 13(Supplement 1):209–214, 2012.
- [Klippel *et al.*, 2013] Alexander Klippel, Rui Li, J. Yang, F. Hardisty, and S. Xu. The Egenhofer-Cohn hypothesis: Or, topological relativity? In M. Raubal, A. Frank, and D. Mark, editors, *Cognitive and Linguistic Aspects of Geographic Space*, pages 195–215. Springer, 2013.
- [Kubat *et al.*, 2009] R. Kubat, D. Mirman, and D. Roy. Semantic context effects on color categorization. In *Proceedings of the Thirty-First Annual Conference of the Cognitive Science Society*, pages 491–495, 2009.
- [Mark, 1999] David M. Mark. Spatial representation: A cognitive view. In P. A. Longley, M. F. Goodchild, D. J. Maguire, and D. W. Rhind, editors, *Geographical information systems*, pages 81–89. Wiley, New York, 1999.
- [Medin *et al.*, 1987] Douglas L. Medin, William D. Wattenmaker, and Sarah E. Hampson. Family resemblance, conceptual cohesiveness, and category construction. *Cognitive Psychology*, 19(2):242–279, 1987.
- [Paolacci *et al.*, 2010] Gabriele Paolacci, Jesse Chandler, and Panagiotis G. Ipeirotis. Running experiments on amazon mechanical turk. *Judgement and Decision Making*, 5(5):411–419, 2010.
- [Ragni and Wölfl, 2005] Marco Ragni and Stefan Wölfl. Temporalizing spatial calculi: On generalized neighborhood graphs. In Ulrich Furbach, editor, *KI*, volume 3698, pages 64–78. Springer, 2005.
- [Renz and Nebel, 2007] Jochen Renz and Bernhard Nebel. Qualitative spatial reasoning using constraint calculi. In Marco Aiello, Ian E. Pratt-Hartmann, and Johan F.A.K. van Benthem, editors, *Handbook of Spatial Logics*, pages 161–215. Springer, 2007.
- [Wallgrün *et al.*, 2007] Jan Oliver Wallgrün, Lutz Frommberger, Diedrich Wolter, Frank Dylla, and Christian Freksa. Qualitative spatial representation and reasoning in the SparQ-toolbox. In T. Barkowsky, M. Knauff, G. Ligozat, and D. Montello, editors, *Spatial Cognition V*, volume 4387, pages 39–58. Springer, 2007.
- [Wallgrün *et al.*, 2012] Jan Oliver Wallgrün, Jinlong Yang, Alexander Klippel, and Frank Dylla. Investigations into the cognitive conceptualization and similarity assessment of spatial scenes. In N. Xiao, M.-P. Kwan, M. F. Goodchild, and S. Shekhar, editors, *Geographic Information Science*, pages 212–225. Springer, 2012.
- [Wallgrün *et al.*, to appear] Jan Oliver Wallgrün, Jinlong Yang, and Alexander Klippel. Investigating intuitive granularities of overlap relations. In *Proceedings 12th IEEE International Conference on cognitive informatics & cognitive computing*, to appear.
- [Wallgrün, 2012] Jan Oliver Wallgrün. Exploiting qualitative spatial reasoning for topological adjustment of spatial data. In *International Conference on Advances in Geographic Information Systems*, pages 229–238, 2012.
- [Westphal *et al.*, 2011] Matthias Westphal, Christian Dornhege, Stefan Wölfl, Marc Gissler, and Bernhard Nebel. Guiding the generation of manipulation plans by qualitative spatial reasoning. *Spatial Cognition & Computation: An Interdisciplinary Journal*, 11(1):75 – 102, 2011.

Using Observations to Derive Cardinal Direction Relations between Regions

Tao Wang and Hui Shi and Bernd Krieg-Brückner

Faculty of Mathematics and Computer Science, University of Bremen
Bremen, Germany 28359

Abstract

Developing models of the environment using spatial observations is a most important task while human or intelligent agent explore or navigate in space, for example, in human-robot cooperating exploration and rescue scenarios. In this paper, we present a novel framework which supports the derivation of spatial configurations using observations in an environment. The framework contains two spatial models, one for the formalization of targeted configurations and one representing observations. Specifically, the cardinal direction matrix for regions and the point-based projection frame are used in this paper as the target and the observation model, respectively. Moreover, a derivation procedure is introduced and proved complete for mapping the cardinal direction relations in the observation model into those in the target model. One significant advantage of our approach is the incremental refinement of environment configurations. Finally, some test results are presented and discussed.

1 Introduction

Observation is an important initial point for people to develop mental models for memorizing and processing in the spatial domain. This knowledge has been adapted in the development of agent systems. Kuipers and his colleagues have suggested the *Spatial Semantic Hierarchy* (e.g. [Kuipers, 2000]) for an agent to explore and learn the structure of a large-scale space, where the agent travels through the space, collecting observations at different locations and deriving global relations between these locations. Furthermore, robotic mapping, an active research area of Robotics and AI, also addresses the problem of acquiring spatial models of environments (typically metric or topological models) through observations obtained by various sensors of mobile robots, including cameras, range finders, etc. (e.g. [Thrun, 2002]). For example, in various robot search and rescue scenarios, qualitatively describing spatial relations between observed objects will improve the communication between human and robot in joint tasks.

Within AI, qualitative spatial models are often used to formalize the location of an object with respect to a different

object (or reference) as spatial relations (see [Allen, 1983; Frank, 1991; Freksa, 1992; Cohn *et al.*, 1997; Goyal and Egenhofer, 2000]). To date, most advanced researches in qualitative spatial modelling and reasoning treat individual models (e.g. [Ligozat, 1998; Renz and Nebel, 1999; Skiadopoulou and Koubarakis, 2004]); or focus on the combination of two models to gain a more powerful one (e.g. [Gerevini and Nebel, 2002; Liu *et al.*, 2009]). In this paper, we do not introduce new spatial models nor investigate a specific calculus, yet we are concerned with deriving and refining spatial configurations in one model (called *target model*) using relations in another one (called *observation model*). Concretely, we focus in the current work on an observation framework with the *Cardinal-Direction Matrix* [Goyal and Egenhofer, 2000] as the target model and the *Projection-based Frame* [Frank, 1991] as the observation model, both of which have been well studied (see [Frank, 1991; Ligozat, 1998; Goyal and Egenhofer, 2000; Skiadopoulou and Koubarakis, 2004; 2005; Liu *et al.*, 2010; Liu and Li, 2011]). For mapping observations at a point in an observation frame into cardinal direction relations between regions, a derivation operation is developed for the framework. One significant benefit of the framework is that it supports straight refinement of cardinal direction relations if further observations are available.

The rest of the paper is structured as follows. Section 2 examines relevant research work. The observation framework is introduced in Section 3. In Section 4 and 5 we show how to derive and refine cardinal direction relations between regions using observations in the projection-based reference frame, and prove the correctness of the derivation procedure. In Section 6 we present some first test results, before concluding in Section 7.

2 Related Work

Qualitative spatial representation and reasoning have drawn substantial attention in various research areas, such as route planning and navigation of intelligent robots (e.g. [Kuipers, 2000]), human-robot interaction (e.g. [Kennedy *et al.*, 2007]), or geographic information system (e.g. [Frank, 1991; Goyal and Egenhofer, 2000]).

Based on different reference frames and different levels of abstraction of objects, such as points, lines or regions, a number of models or calculi of direction (or orientation)

relations have been developed (see [Cohn and Renz, 2008; Bhatt *et al.*, 2011]). Regarding point-based models, there are, for example, the cone-shaped and projection-based direction relations [Frank, 1991], the oriented point algebra OPRA_m with a scalable granularity [Mossakowski and Moratz, 2012], and the basic qualitative trajectory calculus QTCB for representing and reasoning about moving point objects [Weghe *et al.*, 2007].

Models for the direction/orientation relations of lines are, for example, the interval algebra [Allen, 1983], or the double-cross calculus [Freksa, 1992] distinguishing 15 locations of a point with respect to a directed line, which was used to represent poly-lines and grids in [Kuijpers and Moelans, 2008].

Moreover, there are a number of models regarding direction relations between regions. Early work extended Allen’s interval algebra to the two dimensional space [Papadias and Sellis, 1994]. [Goyal and Egenhofer, 2000] proposed a series of spatial models including coarse and deep cardinal direction matrices to achieve a better approximation of direction relations of complex spatial objects, which were further investigated in [Skiadopoulos and Koubarakis, 2004; 2005; Liu *et al.*, 2010; Liu and Li, 2011].

Researchers also investigated how to represent direction relations in heterogeneous models with different types of objects [Kurata and Shi, 2009]. Some research on inter-model operations or integration of existing models can also be found in the literature: combining different models to obtain a more expressive one, for example, combining topological model and cardinal direction model [Liu *et al.*, 2009], route graphs and the double-cross calculus [Krieg-Brückner and Shi, 2006]. There is also research considering model mapping, such as deriving topological relations from given direction relations [Guo and Du, 2009], or generating approximate region boundaries from heterogeneous spatial information [Schockaert *et al.*, 2011]; however, mapping between well-established qualitative spatial relation models is rarely considered.

For deriving cardinal direction relations using projection-based relations, the focus of the current paper, there are two approaches: using converse and composition operations of the corresponding models, or developing direct mapping algorithms. Although for the cardinal direction matrix model, converse and composition operations have been developed [Skiadopoulos and Koubarakis, 2004; 2005; Liu *et al.*, 2010], applying them to derive cardinal direction relations from projection-based relations raises some problems. The consistency check based converse and composition algorithms in [Skiadopoulos and Koubarakis, 2005; Liu *et al.*, 2010] are only designed for regions, and the improved composition algorithm in [Skiadopoulos and Koubarakis, 2004] needs the extended version of the cardinal direction matrix to handle points, which increases the number of single tile relations from 9 to 25; thus the reasoning becomes much more complex. Moreover, how to converse cardinal directions of regions with a point as the reference “region” is still unsolved. Thus, developing a novel approach for mapping point-based cardinal directions into cardinal direction relations between regions is needed.

3 An Observation Framework for Cardinal Directions

Suppose there are a number of *objects* (or *regions*) located in a two-dimensional space. The regions considered in this paper are non-empty, connected and bounded, i.e. regions in REG (e.g., A and B in Fig. 1(a)), see [Skiadopoulos and Koubarakis, 2004] for the definition. Capital letters A , B and C , possibly with an index, are used to represent them. Originally, the cardinal direction relations between A and B are unknown, however they can be observed from different viewpoints (e.g., p or q in Fig. 1(a)).

Each observation captures the local cardinal direction relation between a region and an *observation point*. In this section we introduce a framework including an *observation model* and a *target model*, in which the cardinal direction relations between regions in the target model can be derived (in Section 4) and refined (in Section 5) using observations in the observation model.

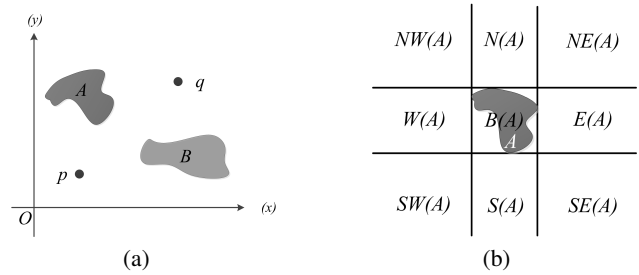

Figure 1: (a) An example scenario and (b) the basic CDM model

In the current *observation framework*, the *direction-relation matrix* (or CDM for short) for cardinal direction relations between regions is used as the target model, while the *projection-based frame* of points is used as the observation model. We first review them briefly and introduce the necessary definitions.

3.1 Target Model

The CDM model has been widely accepted and well studied. It is one of the most expressive models for qualitative spatial reasoning with cardinal direction relations between regions. The basic CDM model concerns cardinal direction relations between regions in REG. The reference region A divides the space into 9 tiles (denoted by $S(A)$, $SW(A)$, $W(A)$, $NW(A)$, $N(A)$, $NE(A)$, $E(A)$, $SE(A)$ and $B(A)$, respectively), using its *minimum bounding box* (a rectangle, as shown in Fig. 1(b)) with A ’s greatest lower bounds (i.e. $inf_x(A)$ and $inf_y(A)$) and least upper bounds (i.e. $sup_x(A)$ and $sup_y(A)$), which are lines parallel to the x - and y -axis, respectively. A *basic cardinal direction relation* can be represented as $R_1 : \dots : R_k$ where $1 \leq k \leq 9$ and $R_i \in \{B, S, SW, W, NW, N, NE, E, SE\}$. If $k = 1$, the basic cardinal direction relation is called *single-tile*; otherwise it is called *multi-tile*, see [Skiadopoulos and Koubarakis, 2004] for detailed and formal definitions. The target model is explicitly called CDM-9 in the current paper.

3.2 Observation Model

The projection-base frame has been introduced for distinguishing cardinal direction relations between two points, hence we call it *cardinal direction-relation model of points* (or CDP for short). As shown in Fig. 2(a), the reference point p of the original projection-based frame divides the whole space into 9 parts by the lines $y = y_p$ and $x = x_p$ parallel to the x - and y -axis, respectively: four semi-lines (denoted by $n(p)$, $s(p)$, $w(p)$ and $e(p)$), four areas (denoted by $ne(p)$, $se(p)$, $sw(p)$, $nw(p)$) and one point (denoted by $c(p)$). Lower-case characters are used in the observation model to represent cardinal directions, in order to distinguish them from those in the target model. p and q , possibly with an index, are used for observation points. As discussed in the subsection 3.1, the regions we consider in the current work are in REG. They are closed, connected and bounded. Since these regions are target objects in the observation model and they cannot be located at a single line or point, and therefore, the simplified frame distinguishing only four areas is adequate for representing the cardinal direction relations between such a region and a point (as illustrated in Fig. 2(b)). In this frame the reference point p separates the whole space into 4 areas (denoted by $ne(p)$, $se(p)$, $sw(p)$, $nw(p)$, respectively) and is simply called CDP-4.

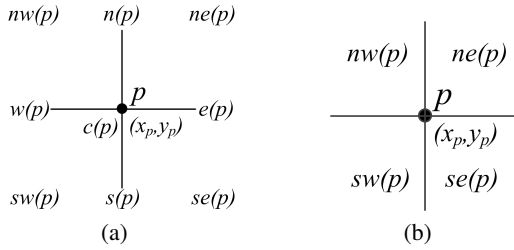

Figure 2: The cardinal direction models for points: (a) the basic model and (b) the simplified model CDP-4

Although the projection-based model has originally been proposed to represent the cardinal direction relations between points, it can be adapted to treat the cases in which targets are regions. To be consistent with the CDM-9 relations, we define a *basic CDP-4 relation* as $r_1 : \dots : r_k$, where

1. $1 \leq k \leq 4$,
2. $r_1, \dots, r_k \in \{\text{nw}, \text{ne}, \text{se}, \text{sw}\}$, and
3. $r_i \neq r_j$ for every i, j , such that $1 \leq i, j \leq k$ and $i \neq j$.

Furthermore, a basic CDP-4 relation $r_1 : \dots : r_k$ is called *single-area* if $k = 1$; otherwise it is called *multi-area*.

The *observation of A from p* (denoted by A_p) is defined as a basic CDP-4 relation. In Fig. 3, for example, B is located completely in the area $se(p)$, thus $B_p = se$; and A lies partially in $nw(p)$ and partially in $ne(p)$, thus $A_p = nw : ne$. Generally, we define the single-area relations as follows.

- $A_p = nw$ iff $y_p \leq \inf_y(A)$ and $\sup_x(A) \leq x_p$
- $A_p = ne$ iff $y_p \leq \inf_y(A)$ and $x_p \leq \inf_x(A)$
- $A_p = se$ iff $\sup_y(A) \leq y_p$ and $x_p \leq \inf_x(A)$

- $A_p = sw$ iff $\sup_y(A) \leq y_p$ and $\sup_x(A) \leq x_p$

A multi-area CDP-4 relation $A_p = r_1 : \dots : r_k$ holds, iff A can be divided by the lines $x = x_p$ and $y = y_p$ into k parts, such that $A_{1p} = r_1, \dots, A_{kp} = r_k$. In Fig. 3, for example, $A_p = nw : ne$, where A_1 is the part of A located in p 's north-west and A_2 in p 's north-east, i.e. $A = A_1 \cup A_2$, $A_{1p} = nw$ and $A_{2p} = ne$.

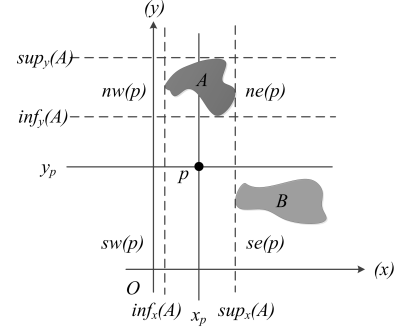

Figure 3: An example of observing regions from point p

3.3 Operations of the Observation Framework

With CDM-9 as the target model and CDP-4 as the observation model, now we consider how to connect them within the observation framework. As mentioned at the beginning, the purpose of observations is to develop spatial relations between observed objects. Therefore, the first operation presented here is the *derivation* operation, which calculates the cardinal direction relations between regions using the observations of these regions from observation points. The derived relations are in the target model CDM-9 and therefore, further reasoning or consistency checking over them is possible as discussed in [Skiadopoulos and Koubarakis, 2004; 2005; Liu *et al.*, 2010; Liu and Li, 2011]. Let A and B be regions in REG, p an observation point. We use $\mathcal{O}_p(A, B)$ to represent the set of *derived basic cardinal direction relations* of B with respect to A using the observations at p , i.e. A_p and B_p .

Obviously, the cardinal direction relations derived from the observations at a single point are often imprecise, due to the limitation of the observation frame, as discussed in the following sections. Gradually adding observations at different points to refine the relations is thus needed. So we introduce the second operation of the observation framework for refining derived cardinal direction relations. Let A and B be regions in REG, p and q observation points. $\mathcal{O}_{\{p,q\}}(A, B)$ is called the set of *refined cardinal direction relations* of B with respect to A according to $\mathcal{O}_p(A, B)$ and $\mathcal{O}_q(A, B)$.

In the following two sections we are going to discuss the operation procedures in detail.

4 Deriving Cardinal Direction Relations Between Regions

The target model CDM-9 of the observation framework uses 9 cardinal directions divided by the minimum bounding box of the reference region, which is a rectangle with

sides parallel to the x - and y -axes. Hence, the observation relation A_p of the reference region A is required to be rectangular, such that the cardinal directions divided by A and by A 's minimum bounding box are the same. A basic cardinal direction relation r in CDP-4 is called *rectangular*, iff there exists a rectangular region X with sides parallel to the x - and y -axes, such that the observation of X from p is r (i.e. $X_p = r$). Therefore, the set of all rectangular observations are the following 9 basic relations: $\{nw, ne, se, sw, nw:ne, ne:se, nw:sw, sw:se, nw:ne:se:sw\}$.

To derive the CDM-9 relations between regions A and B , using the given observations at p , A_p and B_p , we first investigate the relations between each tile of the CDM-9 frame with A as the reference region and the observation point p . Actually, we derive the cardinal direction relation of each tile of A with respect to p from the observation A_p , using the formal definitions of the single-area cardinal direction relations in CDP-4 (see Section 3.2) as well as the single-tile cardinal direction relations in CDM-9 (see [Skiadopoulos and Koubarakis, 2004]).

At first, we consider the cases in which A_p is a single-area relation. Take $A_p = nw$ as an example (see Fig.4), and suppose that G is a region with $G \text{ N } A$. From the formal definitions of cardinal direction relations, we have

$$y_p \leq \inf_y(A) < \sup_y(A) \leq \inf_y(G) \\ \text{and } \sup_x(G) \leq \sup_x(A) \leq x_p,$$

thus $G_p = nw$ holds.

Now we consider the case $G \text{ NE } A$, then

$$\sup_x(A) \leq \inf_x(G) \text{ and } \sup_y(A) \leq \inf_y(G),$$

together with $A_p = nw$, we have

$$y_p \leq \inf_y(A) < \sup_y(A) \leq \inf_y(G), \\ \sup_x(A) \leq \inf_x(G) \text{ and } \sup_x(A) \leq x_p.$$

There are three possibilities:

1. $\sup_x(G) \leq x_p$, then $G_p = nw$;
2. $x_p \leq \inf_x(G)$, then $G_p = ne$;
3. $\inf_x(G) < x_p < \sup_x(G)$, then G can be divided into two parts G_1 and G_2 by the vertical line $x = x_p$ with $G_{1p} = nw$, $G_{2p} = ne$, thus $G_p = nw:ne$.

Combining the above three cases, the possible observations of G_p are $\{nw, ne, nw:ne\}$, i.e., $\Delta(nw, ne)$. $\Delta(r_1, \dots, r_k)$ denotes all possible connected basic CDP-4 relations that can be constructed by combining the single-area relations r_1, \dots, r_k . With the above analyses, it is now possible to derive the possible observations of each tile of the CDM-9 at p using A_p , denoted by A_p^x with $x \in \{B, S, SW, W, NW, N, NE, E, SE\}$. For example, if $A_p = nw$, we have $A_p^N = \{nw\}$; $A_p^{NE} = \Delta(nw, ne)$.

Suppose U stands for the universal CDP-4 relations, i.e. $\Delta(nw, ne, sw, se)$, for any single-area observation $A_p \in \{nw, ne, sw, se\}$ and $x \in \{NW, N, NE, E, SE, S, SW, W, B\}$, then A_p^x can be derived using Table 1.

Below we are going to consider the cases, where A_p is a multi-area and rectangular cardinal direction relation in CDP-4. Let $A_p = r_1 : \dots : r_k$, k is either 2 or 4, otherwise A_p

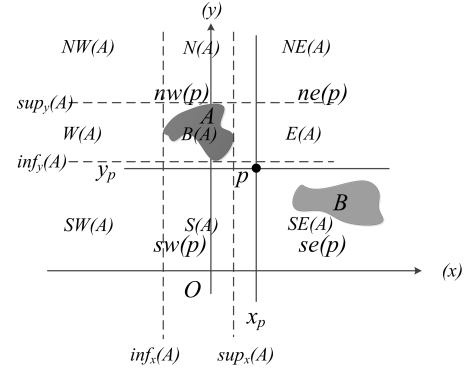

Figure 4: An example for deriving cardinal direction relations using a single-area relation A_p

x / A_p	nw	ne	se	sw
NW	$\{nw\}$	$\Delta(nw, ne)$	U	$\Delta(nw, sw)$
N	$\{nw\}$	$\{ne\}$	$\Delta(ne, se)$	$\Delta(nw, sw)$
NE	$\Delta(nw, ne)$	$\{ne\}$	$\Delta(ne, se)$	U
E	$\Delta(nw, ne)$	$\{ne\}$	$\{se\}$	$\Delta(sw, se)$
SE	U	$\Delta(ne, se)$	$\{se\}$	$\Delta(sw, se)$
S	$\Delta(nw, sw)$	$\Delta(ne, se)$	$\{se\}$	$\{sw\}$
SW	$\Delta(nw, sw)$	U	$\Delta(sw, se)$	$\{sw\}$
W	$\{nw\}$	$\Delta(nw, ne)$	$\Delta(sw, se)$	$\{sw\}$
B	$\{nw\}$	$\{ne\}$	$\{se\}$	$\{sw\}$

Table 1: The transformation table for deriving A_p^x from A_p

is not rectangular. Apparently, the vertical line $x = x_p$ and the horizontal line $y = y_p$ through p divide the region A into k parts, denoted by A_1, \dots, A_k respectively, see Fig. 5 for an example, where $k = 4$. For each pair $A_i \in \{A_1, \dots, A_k\}$ and $r_i \in \{r_1, \dots, r_k\}$, the observation $A_{ip} = r_i$ holds.

Following the definition about the most cardinal direction tiles of a relation in [Skiadopoulos and Koubarakis, 2004] (Definition 8, page 155), we use the notion $Most(x, A)$ to denote CDP-4 areas covering x -most parts of A , where $x \in \{NW, N, NE, E, SE, S, SW, W, B\}$. So, $Most(N, A)$ contains the set of CDP-4 areas covering the north-most parts of A ; or $Most(NW, A)$ contains the set of CDP-4 areas covering the northwest-most parts of A . See Fig. 5, for example, where $A_p = nw:ne:se:sw$, A_1 and A_2 form the north-most parts of A , and the corresponding CDP-4 areas of A_1 and A_2 are nw and ne , thus $Most(N, A) = \{nw, ne\}$. Moreover, A_1 forms the northwest-most part of A , and $A_{1p} = nw$, we have $Most(NW, A) = \{nw\}$. Obviously, $Most(x, A)$ contains either one or two areas.

In Fig. 5, $N(A)$ is the union of $N(A_1)$ and $N(A_2)$, and A_1, A_2 are the north-most parts of A with $A_{1p} = nw$ and $A_{2p} = ne$, thus we have $N(A) = \bigcup_{A_{ip} \in Most(N, A)} N(A_i)$. Furthermore, for any region G located in $N(A)$, there are the following two cases:

1. G is completely located in $N(A_i)$, $i = 1$ or 2 , or
2. G partially lies in $N(A_1)$ and partially in $N(A_2)$.

Combining both cases, the possible observations of G at p , i.e. A_p^N , is $\Delta(\bigcup_{r_i \in Most(N, A)} r_i^N)$. According to Table 1, we

get $nw^N = \{nw\}$ and $ne^N = \{ne\}$, thus $A_p^N = \Delta(nw, ne)$. Generally, for any $x \in \{N, NE, E, SE, S, SW, W, NW, B\}$ we have

$$A_p^x = \Delta\left(\bigcup_{r_i \in \text{Most}(x,A)} r_i^x\right). \quad (1)$$

According to the above analysis, A_p^x indeed captures all the possible observations of a region located in tile x of reference region A at p . With A_p^x and B_p it is now possible to derive the cardinal direction relations of B with A as the reference region in CDM-9. Apparently, if B_p overlaps with A_p^x , which means B and the tile x of A have a common observation at p , then there probably exists a region $B_i \subset B$, such that $B_i \times A$. In general, if $A_p = r_1, \dots, r_k$ and $B_p = s_1, \dots, s_n$, where $k \in \{1, 2, 4\}$ and $n \in \{1, 2, 3, 4\}$, the possible basic cardinal direction relation of B with respect to A derived from the observations A_p and B_p is

$$\mathcal{O}_p(A, B) = \mathcal{C}\left(\prod_{i=1}^n \delta(p_A^{s_i})\right), \quad (2)$$

where p_A^r is defined as the set of tiles of the CDM-9, which can be observed in the area r of the CDP-4 at p , i.e. $p_A^r = \{R | r \in A_p^R\}$; $\delta(S)$ denotes all possible basic CDM-9 relations that can be constructed from element relations in S ; and \mathcal{C} is the filter function which extracts all connected cardinal direction relations from a set of relations.

Now we take the example in Fig. 5 to show the derivation procedure discussed so far, where $A_p = nw : ne : se : sw$ and $B_p = se$. The first step is to compute A_p^x according to Eq. 1 and Table 1, as follows:

A_p^N	$\Delta(nw, ne)$	A_p^{SE}	$\Delta(se)$	A_p^W	$\Delta(nw, sw)$
A_p^{NE}	$\Delta(ne)$	A_p^S	$\Delta(se, sw)$	A_p^{NW}	$\Delta(nw)$
A_p^E	$\Delta(ne, se)$	A_p^{SW}	$\Delta(sw)$	A_p^B	$\Delta(nw, ne, se, sw)$

Then in the second step we compute p_A^{se} using A_p^x from the previous step, and get $p_A^{se} = \{E, SE, S, B\}$.

Finally, we derive $\mathcal{O}_p(A, B)$ using p_A^r , according to Eq. 2. $\mathcal{O}_p(A, B) = \mathcal{C}(\delta(p_A^{se})) = \mathcal{C}(\delta(\{E, SE, S, B\}))$, i.e. $\{B, E, SE, S, B : E, B : S, E : SE, S : SE, B : E : S, B : E : SE, B : S : SE, E : S : SE, B : E : S : SE\}$.

This approach exhibits high performance, when it is used to derive the cardinal direction relations of a number of regions B_1, B_2, \dots, B_n with a region A as the reference. In that case, we only need to compute A_p^x once for each $x \in \{NW, N, NE, E, SE, S, SW, W, B\}$. Using Eq. 2, which is based on standard set operations and thus less expensive, the cardinal direction relations $\mathcal{O}_p(A, B_1), \mathcal{O}_p(A, B_2), \dots$, and $\mathcal{O}_p(A, B_n)$ can then be derived straightforwardly.

5 Refining Cardinal Direction Relations Between Regions

As the example given above shows, deriving cardinal direction relations between A and B using the observations at p (cf. Fig. 5), we obtain a set of 13 basic relations. Generally,

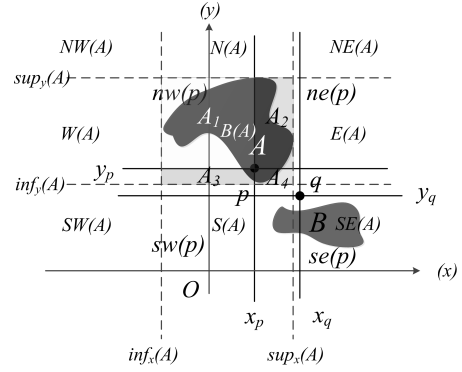

Figure 5: An example for deriving cardinal direction relations using the multi-area relation A_p

deriving cardinal direction relation between two regions using a point-based observation model is imprecise, especially if the reference region can be observed in several areas from the observation point. In this section, we discuss how to refine the derived relations using further observations.

At first, we prove that the set of cardinal direction relations derived through the procedure in Section 4 is complete.

Theorem 1 Let A_p and B_p be observations at point p . If $\mathcal{R}(A, B)$ is the actual CDM-9 relation between region A and region B with A as reference region, then $\mathcal{R}(A, B) \in \mathcal{O}_p(A, B)$.

Proof 1 Suppose $B_p = s_1 : \dots : s_n$, $\mathcal{R}(A, B) = R_1 : \dots : R_k$. Recall Eq. 2, if $\mathcal{R}(A, B) \notin \mathcal{O}_p(A, B)$, then $\exists R_x \in \{R_1, \dots, R_k\}$, $R_x \notin p_A^{s_i} = \{R_{ij} | s_i \in A_p^{R_{ij}}\}$, for all $i = 1, \dots, n$. It is clear that $s_i(p) \subset \cup R_{ij}(A)$, where $R_{ij} \in p_A^{s_i}$, thus $\cup_{i=1}^n s_i(p) \subset (\cup_{i=1}^n \cup R_{ij}(A))$. Moreover, because $R_x \notin p_A^{s_i}$, for all $i = 1, \dots, n$, we have

$$R_x(A) \cap (\cup_{i=1}^n \cup R_{ij}(A)) = \emptyset, \text{ therefore}$$

$$R_x(A) \cap (\cup_{i=1}^n s_i(p)) = \emptyset. \quad (1)$$

Since $\mathcal{R}(A, B) = R_1 : \dots : R_k$, and $R_x \in \{R_1, \dots, R_k\}$, so

$$R_x(A) \cap B \neq \emptyset \text{ and}$$

$$R_x(A) \cap (\cup_{i=1}^n s_i(p)) \neq \emptyset. \quad (2)$$

(1) and (2) are inconsistent. So, $\mathcal{R}(A, B) \in \mathcal{O}_p(A, B)$. \square

Corollary 1 If A_p and B_p , A_q and B_q are observations at p and q , respectively, $\mathcal{R}(A, B)$ the actual CDM-9 relation between region A and region B with A as reference region, then $\mathcal{R}(A, B) \in \mathcal{O}_{\{p,q\}}(A, B) = \mathcal{O}_p(A, B) \cap \mathcal{O}_q(A, B)$.

Additional observations refine the cardinal direction relations between regions through taking common relations from those derived from the observations at individual points and make the result relations more precise.

6 Implementation and Test

In this section we present our first test results of the observation framework using a simulation system, to show the number of observation points and their selections effect the precision of the derived target spatial relations.

Fig.6 shows the test scenario representing an environment map, in which seven objects are manually augmented in a segment of the floor plan of a building. And, 30 observation points are randomly spread in the space, which can be visited by a simulated mobile robot. The test contains seven test runs with different numbers of randomly selected observation points: one with all the 30 points and two with 15, 10 and 5 points, respectively. In each test run, the simulated robot collects observations for all target objects at each selected observation point. Finally, spatial relations between all pairs of the seven objects are calculated using the collected data. Since there are seven objects and one result set for each pair of them, there are 42 sets of relations altogether. The test results are summarized in Table 6.

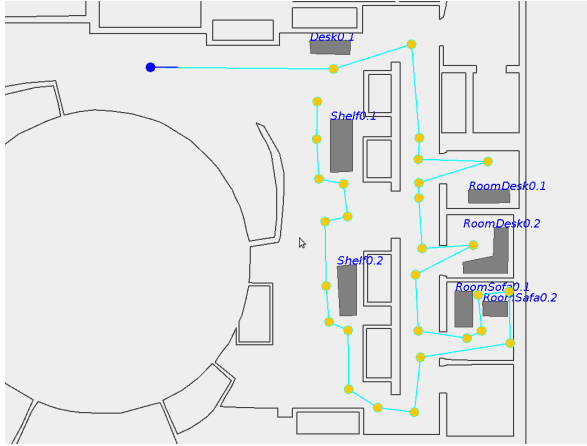

Figure 6: Testing scenario with seven objects, one observation robot and 30 possible observation points

The first column of Table 6 shows the identifiers of test runs, the second contains the number of the observation points in each test run, and the last column is the total number of pairs of the target objects, i.e., 42. The rest columns illustrate the distribution of numbers of possible relations in each result set. For example, if the robot observed the objects at all the 30 observation points, the system generated only one spatial relation between 26 pairs of the objects; in test run 2 with 15 observation points, the system generated from 4 up to 10 possible relations for 3 pairs of objects, and more than 10 relations for one pair of objects.

Test run	Observation points	Relations between two objects					total
		1	2	3	4 ~ 10	>10	
1	30	26	14	2	0	0	42
2	15	18	12	8	3	1	42
3	15	24	4	10	2	2	42
4	10	18	2	8	9	5	42
5	10	20	8	6	6	2	42
6	5	8	0	10	10	14	42
7	5	6	0	14	10	12	42

Table 2: Test results

From Table 6 we can see that generally the more observation points the robot taken, the more precise the spatial relations between the target objects could be generated. Moreover, even though the number of the observation points remains the same, different results can be generated if different observation points are selected (comparing the test runs 2 and 3, 4 and 5, 6 and 7). If the number of observation points is too small, the generated relations may be too ambiguous to be useful (e.g., the test runs 6 and 7).

7 Future Work

In this paper, we introduced an observation framework of the cardinal direction relations with the cardinal direction matrix [Goyal and Egenhofer, 2000; Skiadopoulos and Koubarakis, 2004] as the target model and the projection-based frame [Frank, 1991] as the observation model. The contribution of the work is twofold. First, we developed an efficient procedure that maps projection-based cardinal directions of regions with respect to an observation point into the cardinal direction relations between the regions. Second, the derived cardinal direction relations can be refined straightforwardly using additional observation data. Moreover, the framework was implemented and tested in a simulator, and first test results were presented in the paper.

The derivation process of target relations from observation relations is partially based on the composition operation suggested in [Skiadopoulos and Koubarakis, 2004], which may introduce impossible relations in the result set as pointed out in [Liu *et al.*, 2010]. Although our derivation process may introduce impossible target relations too, for an observation model it is more important that all possible target relations are included (see Theorem 1). Additional observations are then used to reduce impossible ones and to construct the target configuration more precisely. This property of the observation framework suggests an important further research question: How to select observation points such that precise target relations can be derived using as few observations as possible?

Moreover, an implementation of the observation framework in a human-robot joint exploration project is now being carried out. To treat observation failures, which often occur in human or robot observations, the integration of a reasoning procedure is then needed to discover inconsistent relations and communicate them to both the human and the robot during the exploration. Furthermore, we are going to develop derivation procedures for using the Star calculus and the Double-Cross calculus as more powerful observation models.

Acknowledgements

We gratefully acknowledge the support of the Deutsche Forschungsgemeinschaft (DFG) through the Collaborative Research Center SFB/TR8 - Project I5 and the National Natural Science Foundation of China (NFSC) 61272336. We would also like to thank Cui Jian for giving us useful suggestions on the design and implementation of the framework.

References

- [Allen, 1983] J. F. Allen. Maintaining knowledge about temporal intervals. *CACM*, 26(11):832–843, 1983.
- [Bhatt *et al.*, 2011] Mehul Bhatt, Hans Guesgen, Stefan Wöfl, and Shyamanta Hazarika. Qualitative spatial and temporal reasoning: Emerging applications, trends, and directions. *Spatial Cognition & Computation*, 11(1):1–14, 2011.
- [Cohn and Renz, 2008] Anthony G. Cohn and Jochen Renz. Chapter 13 qualitative spatial representation and reasoning. In *Handbook of Knowledge Representation*, volume 3 of *Foundations of Artificial Intelligence*, pages 551 – 596. Elsevier, 2008.
- [Cohn *et al.*, 1997] A. G. Cohn, B. Bennett, J. Gooday, and N. M. Gotts. Qualitative spatial representation and reasoning with the Region Connection Calculus. *Geoinformatics*, 1, 1997.
- [Frank, 1991] A. Frank. Qualitative spatial reasoning about cardinal directions. In *ACSM-ASPRS Auto-Carto 10*, 1991.
- [Freksa, 1992] C. Freksa. Using orientation information for qualitative spatial reasoning. In *Theories and Methods of Spatio-Temporal Reasoning in Geographic Space*, volume 639 of *LNCS*, pages 162–178. Springer-Verlag, 1992.
- [Gerevini and Nebel, 2002] A. Gerevini and B. Nebel. Qualitative spatio-temporal reasoning with rcc-8 and allen’s interval calculus: Computational complexity. In *Proceedings of ECAI 2002*, pages 312–316, 2002.
- [Goyal and Egenhofer, 2000] R. Goyal and M. Egenhofer. Consistent queries over cardinal directions across different levels of detail. In *11th International Workshop on Database and Expert Systems Applications*, pages 876–880, 2000.
- [Guo and Du, 2009] Luo Guo and Shihong Du. Deriving topological relations between regions from direction relations. *Journal of Visual Languages & Computing*, 20(6):368 – 384, 2009.
- [Kennedy *et al.*, 2007] William G. Kennedy, Magdalena D. Bugajska, Matthew Marge, William Adams, Benjamin R. Franssen, Dennis Perzanowski, Alan C. Schultz, and J. Gregory Trafton. Spatial representation and reasoning for human-robot collaboration. In *Proceedings of the AAAI-2007*, pages 1554–1559, 2007.
- [Krieg-Brückner and Shi, 2006] B. Krieg-Brückner and H. Shi. Orientation calculi and route graphs: Towards semantic representations for route descriptions. In *Proceedings of GIScience 2006, Münster, Germany*, volume 4197 of *LNCS*, 2006.
- [Kuijpers and Moelans, 2008] Bart Kuijpers and Bart Moelans. Towards a geometric interpretation of double-cross matrix-based similarity of polylines. In *Proceedings of the 16th ACM SIGSPATIAL international conference on Advances in geographic information systems, GIS ’08*, pages 32:1–32:8, 2008.
- [Kuipers, 2000] B. Kuipers. The Spatial Semantic Hierarchy. *Artificial Intelligence*, 119:191–233, 2000.
- [Kurata and Shi, 2009] Yohei Kurata and Hui Shi. Toward heterogeneous cardinal direction calculus. In *Proceedings of the 32nd annual German conference on Advances in artificial intelligence, KI’09*, pages 452–459, Berlin, Heidelberg, 2009. Springer-Verlag.
- [Ligozat, 1998] G. Ligozat. Reasoning about cardinal directions. *Journal of Visual Languages and Computing*, 9:23–44, 1998.
- [Liu and Li, 2011] Weiming Liu and Sanjiang Li. Reasoning about cardinal directions between extended objects: The np-hardness result. *Artificial Intelligence*, 175(18):2155 – 2169, 2011.
- [Liu *et al.*, 2009] W. Liu, S. Li, and Renz R. Combining RCC-8 with qualitative direction calculi: Algorithms and complexity. In *Proceedings of the 21st international joint conference on Artificial intelligence*, 2009.
- [Liu *et al.*, 2010] Weiming Liu, Xiaotong Zhang, Sanjiang Li, and Mingsheng Ying. Reasoning about cardinal directions between extended objects. *Artificial Intelligence*, 174(12 - 13):951 – 983, 2010.
- [Mossakowski and Moratz, 2012] Till Mossakowski and Reinhard Moratz. Qualitative reasoning about relative direction of oriented points. *Artificial Intelligence*, 180-181(0):34 – 45, 2012.
- [Papadias and Sellis, 1994] Dimitris Papadias and Timos Sellis. Qualitative representation of spatial knowledge in two-dimensional space. *The VLDB Journal*, 3:479–516, 1994.
- [Renz and Nebel, 1999] J. Renz and B. Nebel. On the complexity of qualitative spatial reasoning: A maximal tractable fragmentation of the region connection calculus. *Artificial Intelligence*, 108(1-2):69–123, 1999.
- [Schockaert *et al.*, 2011] Steven Schockaert, Philip D. Smart, and Florian A. Twaroch. Generating approximate region boundaries from heterogeneous spatial information: An evolutionary approach. *Information Sciences*, 181(2):257 – 283, 2011.
- [Skiadopoulos and Koubarakis, 2004] S. Skiadopoulos and M. Koubarakis. Composing cardinal direction relations. *Artificial Intelligence*, 152(2):147–171, 2004.
- [Skiadopoulos and Koubarakis, 2005] S. Skiadopoulos and M. Koubarakis. On the consistency of cardinal direction constrains. *Artificial Intelligence*, 163:91–135, 2005.
- [Thrun, 2002] S. Thrun. Robotics mapping: a survey. In G. Lakemeyer and B. Nebel, editors, *Exploring Artificial Intelligence in the New Millenium*. Morgan Kaufmann, 2002.
- [Weghe *et al.*, 2007] Nico Van De Weghe, Peter Bogaert, Anthony G. Cohn, Matthias Delafontaine, Leen De Temmerman, Tijs Neutens, and Frank Witlox. How to handle incomplete knowledge concerning moving objects, 2007.

Workshop Report

27th International Workshop on Qualitative Reasoning (QR 2013). Editors: Mehul Bhatt, Peter Struss, and Christian Freksa. Technical Workshop Report., Report Series of the Transregional Collaborative Research Center SFB/TR 8 Spatial Cognition, Universität Bremen / Universität Freiburg, Bremen, Germany.